

masterbook 2016



masterbook 2016





INDICE GENERALE

MASTER INDEX / GESAMTINHALT / INDEX GENERAL / ÍNDICE GENERAL

Archicolor Project	04	CERDISASTONE	122
Storia	06	Altaj	124
Ambiente	08	Cementi	128
		Chalet	132
AREATECH	10	Grange	138
Archistone	12	Home Teak	148
Archistone Wallproject	20	Natura	156
Archistone T20	23	Neostone	164
Blackboard	24	Steam Wood	170
Dolmen Levitas T5,6	36		
EC1	46	TECH-INFO	178
EC1 Levitas T5,6	54	Simbologia	180
Formwork	64	Certificazioni	180
Portland	70	Consigli di posa	184
Puntozero	76	Manutenzione	186
Reden	86	Tabelle Tecniche Areatech	188
Tinte Unite / Graniti	98	Prodotti Antiscivolo	190
		Tabelle Tecniche Cerdisastone	193
POOL COLLECTION	102		
H ₂ O Life Project	104		
H ₂ O Sport Project	112		



WHITE



FORMWORK
WHITE
pag. 64



NATURA
ABETE BI
pag. 156



HOME TEAK
ICE TEAK
pag. 148



FORMWORK
GAINSBORO
pag. 64

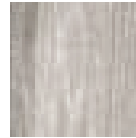

STEAM WOOD
PEARL WHITE BI
pag. 170

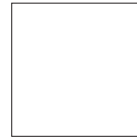
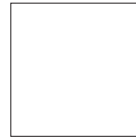

GREY



STEAM WOOD
ASH GR
pag. 170



HOME TEAK
CLOUD TEAK
pag. 148



NATURA
ULIVO
pag. 156

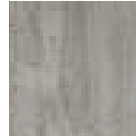

FORMWORK
ASH
pag. 64



HOME TEAK
LONDON TEAK
pag. 148



CHALET
NERO
pag. 132

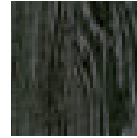

STEAM WOOD
CHARCOAL AN
pag. 170



HOME TEAK
DARK TEAK
pag. 148

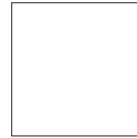
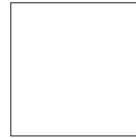

BROWN



CHALET
BIANCO
pag. 132



NATURA
FRASSINO
pag. 156



STEAM WOOD
BLONDE ALE ST
pag. 170



CHALET
ROVERE
pag. 132



CHALET
CILIEGIO
pag. 132



NATURA
MOGANO
pag. 156

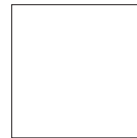

BEIGE



HOME TEAK
CREAM TEAK
pag. 148



HOME TEAK
HONEY TEAK
pag. 148

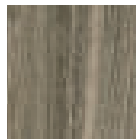

STEAM WOOD
DOVE GRAY TO
pag. 170



STEAM WOOD
REDDISH BROWN PR
pag. 170



NATURA
MULTICOLOR
pag. 156



NATURA
SELVA
pag. 156

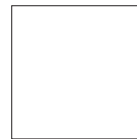

ARCHICOLOR
PROJECT

NEUTRAL



PORTLAND
AVORIO
pag. 70



CEMENTI
BIANCO
pag. 128



ARCHISTONE
LIMESTONE BIANCO
pag. 12

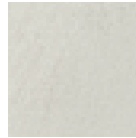

PUNTOZERO
LATTE
pag. 76



BLACKBOARD
WHITE
pag. 24



NEOSTONE
AVORIO
pag. 164



ARCHISTONE
LIMESTONE CREMA
pag. 12

WARM
NEUTRAL



DOLMEN
BIANCO
pag. 36



EC1
FARRINGDON B
pag. 46



CEMENTI
AVORIO
pag. 128



EC1
BANK SA
pag. 46



ARCHISTONE
PIETRA DI BAVARIA
pag. 12



DOLMEN
BEIGE
pag. 36

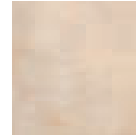

PORTLAND
BEIGE
pag. 70



REDEN
IVORY
pag. 86



PORTLAND
TORTORA
pag. 70



BEIGE



DOLMEN
CENERE
pag. 36



PUNTOZERO
RISO
pag. 76



GRANGE
WHEAT
pag. 138



EC1
HOLBORN TA
pag. 46



BLACKBOARD
MUD
pag. 24



PUNTOZERO
BISCOTTO
pag. 76



BROWN

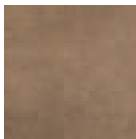

GRANGE
EMBERS
pag. 138



REDEN
BISCUIT
pag. 86

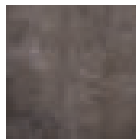

PORTLAND
BRONZO
pag. 70

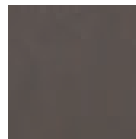

EC1
DOCKS FA
pag. 46



CEMENTI
FANGO
pag. 128



COLD
GREY



PORTLAND
GRIGIO CHIARO
pag. 70



GRANGE
GRAVEL
pag. 138



REDEN
GREY
pag. 86



PUNTOZERO
NUVOLA
pag. 76



PORTLAND
GRIGIO AZZURRO
pag. 70



PUNTOZERO
CENERE
pag. 76



WARM
GREY



PUNTOZERO
CORDA
pag. 76

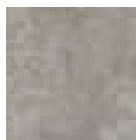

GRANGE
PATH
pag. 138



NEOSTONE
GRIGIO
pag. 164



CEMENTI
GRIGIO
pag. 128



DARK
GREY

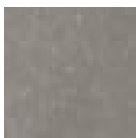

ARCHISTONE
LIGHTSTONE
pag. 12



BLACKBOARD
ASH
pag. 24



ARCHISTONE
GRAFITE
pag. 12



CEMENTI
ANTRACITE
pag. 128



EC1
CITY AN
pag. 46



NEOSTONE
ANTRACITE
pag. 164



BLACK

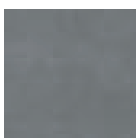

PORTLAND
GRIGIO SCURO
pag. 70



DOLMEN
GRAFITE
pag. 36

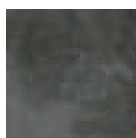

REDEN
DARK GREY
pag. 86

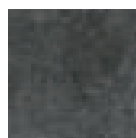

BLACKBOARD
ANTRACITE
pag. 24



EC1
BARBICAN NE
pag. 46



ARCHISTONE
DARKSTONE
pag. 12

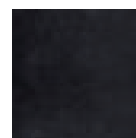

CEMENTI
NERO
pag. 128

L'eccellenza: tra tradizione e innovazione

Excellence: a blend of tradition and innovation / Qualität: Tradition und Innovation

L'excellence : entre tradition et innovation / La excelencia: entre la tradición y la innovación



Cerdisa Ceramiche di Sassuolo fondata nel 1959, nasce come industria produttrice di piastrelle da rivestimento in pasta bianca, per poi allargare e diversificare la sua offerta seguendo gli sviluppi della tecnologia produttiva più innovativa, attuata negli stabilimenti del **Gruppo Ceramiche Ricchetti Spa**. Cerdisa è stata una delle primissime aziende a produrre Gres Fine Porcellanato e ad entrare a pieno titolo nel mondo dei grandi progetti. Oggi il marchio Cerdisa identifica una serie di prodotti in ceramica da pavimento e rivestimento dalle forti valenze estetiche e tecnologiche, con un posizionamento nel segmento più alto del mercato per ricerca, creatività e qualità. L'innovazione è radicata in un patrimonio di esperienza e ricerca che si sono consolidate nel tempo, orientandosi sempre di più verso le esigenze dei propri clienti con l'offerta di soluzioni a servizio completo per costruire ambienti accessibili dal singolo e dalla collettività.

Cerdisa Ceramiche of Sassuolo founded in 1959, was established as a manufacturer of white-body wall tiles, before extending and diversifying its offering in response to the development of cutting-edge production technologies at the plants of the **Ceramiche Ricchetti Group Spa**. Cerdisa was one of the very first companies to produce fine porcelain stoneware and win recognition in the major projects sector. Today, the Cerdisa brand offers a range of ceramic floor and wall coverings with high appearance and technology values, positioned at the high end of the market in terms of research, creativity and quality. Its innovation is rooted in a legacy of experience and research consolidated over time, with an ever-increasing focus on the needs of its customers, reflected in full-service solutions for the construction of design schemes suitable for the individual or the community.

Cerdisa Ceramiche, Sassuolo, wurde 1959 als Unternehmen für die Herstellung von weißscherbigen Wandfliesen gegründet. In den Folgejahren erfuhr das Produktsortiment im Zuge der technologischen Weiterentwicklung an den Standorten der **Gruppo Ceramiche Ricchetti Spa** eine Erweiterung und Diversifizierung. Cerdisa zählte zu den ersten Herstellern von Feinsteinzeug und Objektkeramik. Heute steht die Marke Cerdisa für keramische Boden- und Wandfliesen mit erstklassigen optischen und technischen Eigenschaften, die aufgrund ihrer Erlesenheit, Kreativität und Qualität im oberen Preissegment angesiedelt sind. Die Innovation wurzelt in der langjährigen Kompetenz und Erfahrung im Angebot von Komplettlösungen für private und öffentliche Bereiche, die den kundenspezifischen Anforderungen Rechnung tragen.

Fondée en 1959, **Cerdisa Ceramiche** de Sassuolo voit le jour en tant qu'industrie productrice de carreaux de revêtement en pâte blanche. Au fil des ans, elle élargit et diversifie son offre, mise en œuvre dans les établissements du **Groupe Ceramiche Ricchetti Spa** en s'appuyant sur les développements d'une technologie de production très innovante. Cerdisa a été l'une des toutes premières entreprises à produire du grès cérame fin et à s'inscrire pleinement dans le monde des grands projets. Aujourd'hui, la marque Cerdisa identifie toute une offre de produits de revêtements céramiques pour sols et murs à valeur esthétique et technologique forte, avec un positionnement sur un segment de marché haut de gamme en termes de recherche, de créativité et de qualité. L'innovation s'appuie sur l'expérience et la recherche enracinées dans un patrimoine, et qui se sont consolidées au fil du temps. Son évolution est axée sur les exigences de ses clients, avec des solutions complètes de prestations pour construire des environnements accessibles aux particuliers et à la collectivité.

Cerdisa Ceramiche de Sassuolo, empresa fundada en 1959, nace como industria productora de azulejos para revestimiento de pasta blanca, si bien después amplía y diversifica su oferta siguiendo el desarrollo de la tecnología de fabricación más innovadora, que se implementa y aplica en los establecimientos del **Grupo Ceramiche Ricchetti Spa**. Cerdisa fue una de las primeras empresas en dedicarse a la fabricación de Gres Fino Porcelánico y entrar de lleno en el mundo de los grandes proyectos. Actualmente la firma Cerdisa identifica una serie de productos de cerámica para pavimento y revestimiento de extraordinario valor estético y tecnológico y está posicionada en el segmento más alto del mercado gracias a su labor de investigación, su creatividad y calidad. La innovación hunde sus raíces en un bagaje de experiencia e investigación consolidado a lo largo del tiempo y se orienta cada vez más hacia la satisfacción de las exigencias de los clientes ofreciendo soluciones que prestan un servicio completo en la construcción de espacios accesibles tanto para cada persona como para la colectividad.

Soluzioni per il progetto contemporaneo

Solutions for contemporary architecture / Moderne Objektlösungen

Des solutions pour un projet contemporain / Propuestas para proyectos contemporáneos



Tradizione ceramica ed estetica rigorosamente Made in Italy, esperienza e innovazione si traducono in un'eccellenza che indirizza la ricerca di Cerdisa verso nuove soluzioni per il mondo dell'architettura e del progetto. In linea con le tendenze del design più evoluto Cerdisa produce piastrelle ricche di fascino e funzionalità: prodotti trasversali per un utilizzo in interno ed esterno, a pavimento e rivestimento con soluzioni coordinate per l'edilizia commerciale e residenziale. Cerdisa dedica grande energia per tutelare e rafforzare la qualità e l'originalità dei suoi prodotti, attraverso un continuo e costante investimento nell'innovazione e nell'implementazione di nuovi processi produttivi. Dal prodotto, passando attraverso il servizio e gli strumenti di comunicazione che l'azienda mette a disposizione dei suoi clienti, scaturisce un'identità forte, immediata e riconoscibile, dallo stile contemporaneo ed essenziale.

Strictly all-Italian ceramic tile tradition and styling, experience and innovation, are all combined in an excellence that guides Cerdisa towards new solutions for the world of architecture and large projects. In line with cutting-edge design trends, Cerdisa produces tiles that are beautiful yet functional: versatile products, for use indoors and outdoors, floors and walls, with coordinated solutions for the commercial and residential construction sectors. Cerdisa devotes considerable energy to safeguarding and reinforcing its products' quality and originality, through continual, constant investment in innovation and the implementation of new production processes. Aided by the service and the advertising tools the company provides its customers, with products that have a strong, immediate, distinctive identity, with a contemporary, essential style.

Keramik- und Designtradition Made in Italy. Erfahrung und Innovation legen den Grundstein für einen Qualitätsanspruch, der das Augenmerk von Cerdisa auf neue Architektur- und Objektlösungen richtet. In Übereinstimmung mit den neuesten Designrends produziert Cerdisa faszinierende und funktionelle Fliesen: Vielseitige Produkte für kombinierte Boden- und Wandbekleidungen in Innen- und Außenbereichen für gewerbliche und private Bauobjekte. Cerdisa ist um die Wahrung und Steigerung der Qualität und Originalität der eigenen Produkte bemüht. Hierfür investiert das Unternehmen kontinuierlich und konstant in die Innovation und Implementierung von neuen Herstellungsverfahren. Beginnend beim Produkt über den Service bis hin zu den Kommunikationstools, die das Unternehmen für seine Kunden bereithält, entsteht eine starke, eingängige und wiedererkennbare Identität, die einen zeitgemäßen, minimalistischen Stil verkörpert.

L'excellence traduit la tradition céramique et esthétique rigoureusement « Made in Italy » de Cerdisa, dont la recherche est orientée vers de nouvelles solutions pour le monde de l'architecture et des projets. En phase avec les tendances du design le plus évolué, Cerdisa fabrique des carrelages empreints de charme et de fonctionnalité : des produits transversaux pour un usage en extérieur et en intérieur, des revêtements pour sols et murs aux solutions coordonnées pour les bâtiments commerciaux et résidentiels. Cerdisa consacre une grande énergie à la valorisation et au renforcement de la qualité et de l'originalité de ses produits, investissant continuellement dans l'innovation et la mise en œuvre de nouveaux processus de production. Une identité forte, immédiate et reconnaissable, au style contemporain et essentiel en résulte, fondée sur le produit, le service et les outils de communication que l'entreprise met à disposition de ses clients.

Tradición cerámica y estética rigurosamente "made in Italy", experiencia e innovación se traducen en una excelencia que orienta la investigación de Cerdisa hacia nuevas soluciones para el mundo de la arquitectura y los proyectos. En sintonía con las tendencias del más avanzado diseño Cerdisa fabrica azulejos llenos de encanto y funcionalidad: se trata de productos transversales válidos tanto para espacios interiores como exteriores, para pavimentar suelos y revestir paredes, con propuestas coordinadas tanto para la construcción comercial como para la residencial. Cerdisa dedica una enorme energía a salvaguardar y reforzar la calidad y originalidad de sus productos mediante una continua y constante inversión en innovación y en la implementación de nuevos procesos de fabricación. Con el producto que ofrece, el servicio que presta y las herramientas de comunicación que pone a disposición de sus clientes, la firma transmite una identidad fuerte, inmediata y perfectamente reconocible, de estilo contemporáneo y austero.

Il rispetto per l'ambiente

Environment-friendliness / Aus Liebe zur Umwelt / Le respect de l'environnement / Respeto por el medio ambiente





Un atteggiamento etico e responsabile caratterizza l'impegno di Cerdisa nei confronti dell'ambiente e delle persone che ne fanno parte. Da molto tempo l'azienda si è attivata per migliorare i processi produttivi e la qualità dei prodotti attraverso una riduzione dei consumi, l'utilizzo di energie rinnovabili. Impianti tecnologicamente all'avanguardia operano con un sistema di raccolta e di utilizzo degli scarti di produzione e delle acque di lavorazione, garantendo la massima qualità durante l'intero processo di produzione, certificato secondo le norme **UNI EN ISO 9001**. Cerdisa fa parte dell' **U.S Green Building Council (USGBC)**, l'associazione americana che si occupa di implementare e regolamentare la costruzione di edifici sostenibili attraverso la certificazione **LEED®** (Leadership in Energy and Environmental Design). Grazie alle caratteristiche tecnico-strutturali di contenuto variabile dal 20% al 40% di materiale riciclato, molte serie a marchio Cerdisa hanno contribuito al raggiungimento di crediti LEED.

Cerdisa takes an ethical, responsible attitude to the environment and the people who belong to it. The company has been working for a long time to improve production processes and product quality by reducing consumption and using renewable energy sources. Plants at the technological state of the art work with a system for the collection and reuse of production waste and process water, guaranteeing the very highest quality throughout the entire production process, certified in accordance with the **UNI EN ISO 9001** standards. Cerdisa is a member of the **U.S. Green Building Council (USGBC)**, the American association that implements and regulates the construction of sustainable buildings by means of **LEED®** (Leadership in Energy and Environmental Design) certification. Thanks to their technical-structural characteristics and 20% to 40% recycled material content, many Cerdisa brand products are able to contribute to a building's LEED® score.

Ethik und Verantwortlichkeit kennzeichnen das Engagement von Cerdisa gegenüber der Umwelt und dem Menschen. Seit vielen Jahren optimiert das Unternehmen seine Produktionsprozesse und die Produktqualität durch verbrauchssenkende Maßnahmen und die Verwendung von erneuerbaren Energien. Hochmoderne Anlagen arbeiten mit einem System für die Sammlung und Wiederverwendung von Produktionsabfällen und Prozesswasser und garantieren damit höchste Qualitätsstandards im gesamten Produktionsprozess, die gemäß **UNI EN ISO 9001** zertifiziert sind. Cerdisa ist Mitglied des **U.S. Green Building Council (USGBC)**, des US-amerikanischen Verbands für die Implementierung und Normierung von nachhaltigem Bauen anhand der **LEED®**-Zertifizierung (Leadership in Energy and Environmental Design). Zahlreiche Produkte der Marke Cerdisa können aufgrund ihrer technisch-strukturellen Eigenschaften und ihres Recyclinganteils von 20 % bis 40 % zur Erreichung der notwendigen Punktezahl für Gebäude gemäß den LEED®-Parametern beitragen.

Une attitude éthique et responsable : c'est ce qui définit l'engagement de Cerdisa envers l'environnement et les personnes qui en font partie. Depuis très longtemps déjà, l'entreprise a mis en œuvre les améliorations de ses processus de production et de la qualité de ses produits en réduisant la consommation et en utilisant les énergies renouvelables. Des établissements d'avant-garde au plan technologique travaillent avec un système de recueil et de recyclage des déchets industriels et des eaux de traitement, garantissant ainsi la plus grande qualité durant tout le processus de production, certifié selon les normes **UNI EN ISO 9001**. Cerdisa fait partie du **U.S. Green Building Council (USGBC)**, l'association américaine qui s'occupe de mettre en œuvre et de réglementer la construction d'édifices durables à travers la certification **LEED®** (Leadership in Energy and Environmental Design). Du fait de leurs caractéristiques technico-structurales et d'un pourcentage variant entre 20 et 40 % du contenu en matériel recyclé, de nombreux produits de la marque Cerdisa peuvent contribuer à l'atteinte du nombre de points attribués à un bâtiment, selon les paramètres LEED®.

Una actitud ética y responsable caracteriza el compromiso de Cerdisa para con el medio ambiente y las personas que lo habitan. Desde hace mucho tiempo la empresa viene tomando medidas para mejorar sus procesos productivos y la calidad de sus productos a través de la reducción del consumo y el empleo de energías renovables. Las instalaciones, de vanguardia desde el punto de vista tecnológico, incorporan sistemas de recogida y uso de los residuos de producción y las aguas de elaboración; además garantizan la máxima calidad a lo largo de todo el proceso de fabricación, que cuenta con la certificación de conformidad con las normas **UNI EN ISO 9001**. Cerdisa forma parte del **U.S. Green Building Council (USGBC)**, el organismo estadounidense que se ocupa de implementar y reglamentar la construcción de edificios sostenibles a través de la certificación **LEED®** (Leadership in Energy and Environmental Design). Muchos de los productos que llevan el sello de Cerdisa, por sus características técnicas y estructurales y por la cantidad de material reciclado que contienen (con porcentajes que van del 20 al 40%), pueden contribuir a lograr la puntuación que, de acuerdo con los parámetros LEED®, se le exige a un edificio para conseguir dicha certificación.



AREATECH



archistone

Gres fine porcellanato / Fine porcelain stoneware / Feinsteinzeug / Grès cérame fin / Gres fino porcelánico **UNI EN 14411 G Bla**



Limestone Bianco Lapp. Rett. 60x120 / 30x120



Formati / Sizes / Grösse / Format / Tamaño:



60x120 Rett.
24"x48"



30x120 Rett.
12"x48"



60x60 Rett.
24"x24"



30x60 Rett.
12"x24"



30x30 Rett.
12"x12"

Superfici / Surface / Oberfläche / Surface / Superficie

NATURALE / NATURAL / NATUR / NATUREL / NATURAL

LAPPATO / SEMI-POLISHED / LEICHT POLIERT / SEMI-POLI / PULIDO

GRIP / GRIP / GRIP OBERFLÄCHE / GRIP / ANTIDESLIZANTE

archistone

Gres fine porcellanato / Fine porcelain stoneware / Feinsteinzeug / Grès cérame fin / Gres fino porcelánico **UNI EN 14411 G Bla**



Pietra di Bavaria Grip 60x60 / 30x60 / 30x30
Mosaico 3D Pietra di Bavaria Rett. 30x60



Limestone Crema Grip 60x120

archistone

Gres fine porcellanato / Fine porcelain stoneware / Feinsteinzeug / Grès cérame fin / Gres fino porcelánico **UNI EN 14411 G Bla**



Limestone Bianco Lapp. Rett. 60x60
Mosaico 3D Limestone Bianco Rett. 30x60



Grafite Grip 60x60
Mosaico 3D Grafite Rett. 30x60



Lightstone Nat. Rett. 60x60
Mosaico 3D Lightstone Rett. 30x60

archistone

Gres fine porcellanato / Fine porcelain stoneware / Feinsteinzeug / Grès cérame fin / Gres fino porcelánico **UNI EN 14411 G Bla**

Grafite

Limestone Bianco

Limestone Crema

NATURALE
NATURAL / NATUR / NATUREL / NATURAL

LAPPATO
SEMI-POLISHED / LEICHT POLIERT / SEMI-POLI / PULIDO

GRIP
GRIP / GRIP OBERFLÄCHE / GRIP / ANTIDESLIZANTE





Classement

	U	P	E	C	Gel
60x120 Nat./Grip/Lapp.	U4	P3	E3	C2	S
30x120 Nat./Grip/Lapp.	U4	P3	E3	C2	S
60x60 - 30x30 Nat./Grip/Lapp.	U4	P4+	E3	C2	S
30x60 Nat./Grip/Lapp.	U4	P4	E3	C2	S

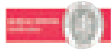

Grip R10 A+B > 0,60 dry / > 0,60 wet
 Grip R11 A+B+C > 0,60 dry / > 0,60 wet

PENDULUM TEST BS 7976

Grip R10 A+B > 36 dry / < 25 wet
 Grip R11 A+B+C > 36 dry / > 36 wet



BOT 3000 ANSI A 137.1:2012 DCOF ≥ 0,42

Darkstone

Lightstone

Pietra di Bavaria

NATURALE
 NATURAL / NATUR / NATUREL / NATURAL

LAPPATO
 SEMI-POLISHED / LEICHT POLIERT / SEMI-POLI / PULIDO

GRIP
 GRIP / GRIP OBERFLÄCHE / GRIP / ANTIDESLIZANTE



archistone wallproject

Gres fine porcellanato / Fine porcelain stoneware / Feinsteinzeug / Grès cérame fin / Gres fino porcelánico **UNI EN 14411 G Bla**

DECORO PIZZO 30x60 /12"x24" 4 pcs x box

Grafite Rett.
0050785



Limestone Bianco Rett.
0050725

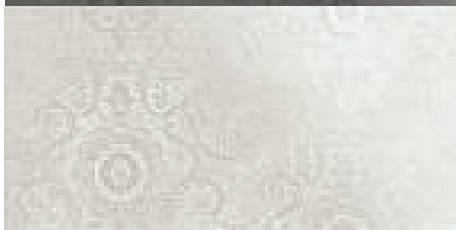

Limestone Crema Rett.
0050755



Darkstone Rett.
0050885

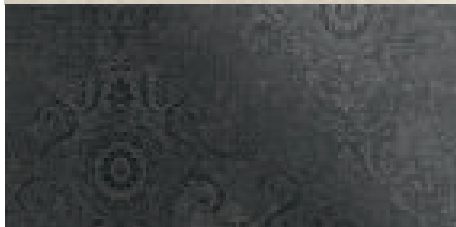

Lightstone Rett.
0050855

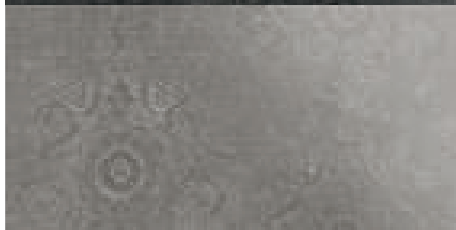

DECORO TRAMA 30x60 /12"x24" 4 pcs x box

Grafite Rett.
0050786

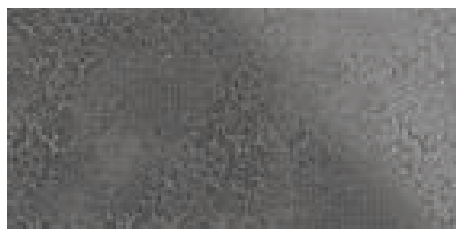

Limestone Bianco Rett.
0050726



Limestone Crema Rett.
0050756

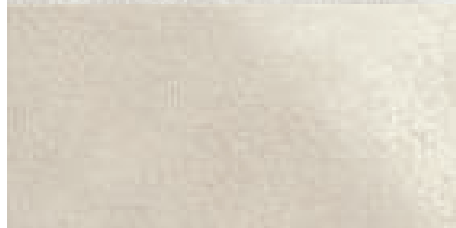

Darkstone Rett.
0050886

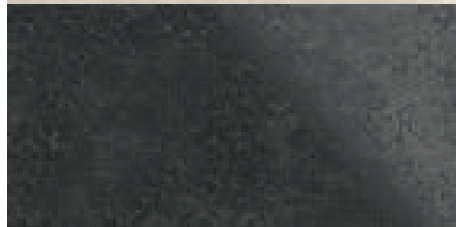

Lightstone Rett.
0050856



DECORO DAMASCATO



Grafite Rett.
0050784



Limestone Bianco Rett.
0050724



Limestone Crema Rett.
0050754



Darkstone Rett.
0050884

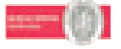

V2
Grafite
Lightstone
Limestone

V3
Darkstone
Pietra
di Bavaria

V4
Pietra
di Bavaria

MOSAICO 30x30 /12"x12" 4 pcs x box

Grafite Rett.
0050781

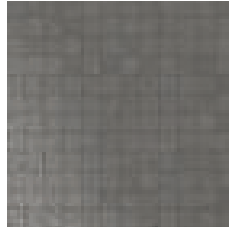
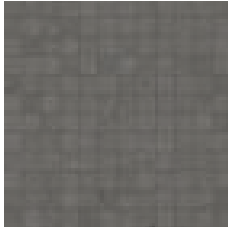

Limestone Bianco Rett.
0050721

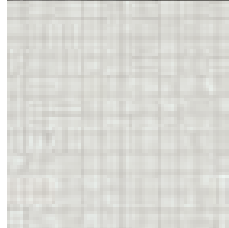

Limestone Crema Rett.
0050751

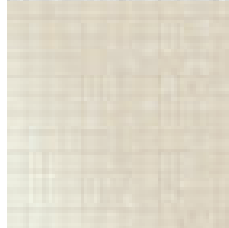

Darkstone Rett.
0050881

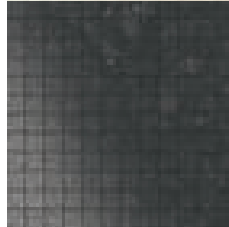
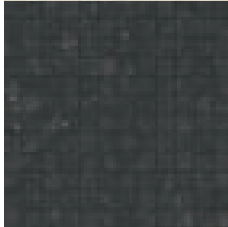

Lightstone Rett.
0050851

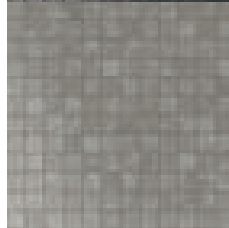
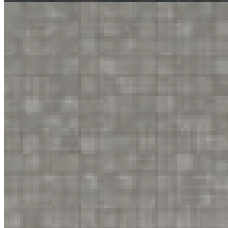

Pietra di Bavaria Rett.
0050821

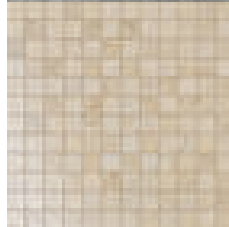
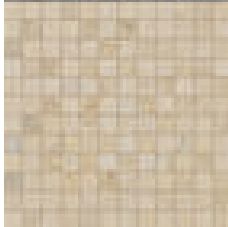

Grafite Lapp.
0050782

Limestone Bianco Lapp.
0050722

Limestone Crema Lapp.
0050752

Darkstone Lapp.
0050882

Lightstone Lapp.
0050852

Pietra di Bavaria Lapp.
0050822

MOSAICO 3D 30x60 /12"x24" 4 pcs x box



0050783 - Grafite Rett.



0050723 - Limestone Bianco Rett.



0050753 - Limestone Crema Rett.

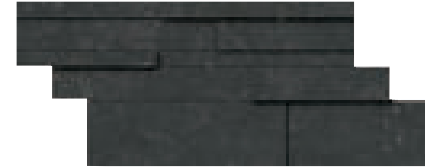

0050883 - Darkstone Rett.



0050853 - Lightstone Rett.



0050823 - Pietra di Bavaria Rett.

archistone

Gres fine porcellanato / Fine porcelain stoneware / Feinsteinzeug / Grès cérame fin / Gres fino porcelánico **UNI EN 14411 G Bia**



	Classement				
	U	P	E	C	Gel
60x120 Nat./Grip/Lapp.	U4	P3	E3	C2	S
30x120 Nat./Grip/Lapp.	U4	P3	E3	C2	S
60x60 - 30x30 Nat./Grip/Lapp.	U4	P4+	E3	C2	S
30x60 Nat./Grip/Lapp.	U4	P4	E3	C2	S

PENDULUM TEST BS 7976
 Grip R10 A+B > 36 dry / < 25 wet
 Grip R11 A+B+C > 36 dry / > 36 wet

ASTM
 Grip R10 A+B > 0,60 dry / > 0,60 wet
 Grip R11 A+B+C > 0,60 dry / > 0,60 wet

BOT 3000
 ANSI A 137.1:2012
 DCOF ≥ 0,42

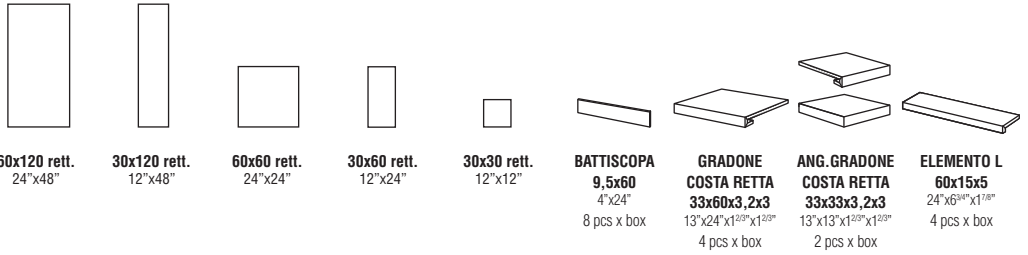

NATURALE

NATURAL / NATUR / NATUREL / NATURAL

Grafite	0050788	0051020	0050771	0050773	-	0050777	0050779	0050780	-
Limestone Bianco	0050728	0051000	0050711	0050713	-	0050717	0050719	0050720	-
Limestone Crema	0050758	0051010	0050741	0050743	-	0050747	0050749	0050750	-
Darkstone	0050888	0051050	0050871	0050873	0050875	0050877	0050879	0050880	-
Lightstone	0050858	0051040	0050841	0050843	0050845	0050847	0050849	0050850	-
Pietra di Bavaria	0050828	0051030	0050811	0050813	0050815	0050817	0050819	0050820	-

LAPPATO

SEMI-POLISHED / LEICHT POLIERT / SEMI-POLI / PULIDO

Grafite	0050789	0051021	0050772	0050774	-	0050778	-	-	-
Limestone Bianco	0050729	0051001	0050712	0050714	-	0050718	-	-	-
Limestone Crema	0050759	0051011	0050742	0050744	-	0050748	-	-	-
Darkstone	0050889	0051051	0050872	0050874	0050876	0050878	-	-	-
Lightstone	0050859	0051041	0050842	0050844	0050846	0050848	-	-	-
Pietra di Bavaria	0050829	0051031	0050812	0050814	0050816	0050818	-	-	-

GRIP

GRIP / GRIP OBERFLÄCHE / GRIP / ANTIDESLIZANTE

Grafite	0050797	0051022	0050791	0050792	-	-	-	-	0050795
Limestone Bianco	0050737	0051002	0050731	0050732	-	-	-	-	0050735
Limestone Crema	0050767	0051012	0050761	0050762	-	-	-	-	0050765
Darkstone	0050897	0051052	0050891	0050892	0050893	-	-	-	0050895
Lightstone	0050867	0051042	0050861	0050862	0050863	-	-	-	0050865
Pietra di Bavaria	0050837	0051032	0050831	0050832	0050833	-	-	-	0050835

GRIP 20mm - R11 A+B+C

GRIP / GRIP OBERFLÄCHE / GRIP / ANTIDESLIZANTE

Grafite R11 A+B+C	-	-	0050799	-	-	-	-	-	-
Limestone Bianco R11 A+B+C	-	-	0050739	-	-	-	-	-	-
Limestone Crema R11 A+B+C	-	-	0050769	-	-	-	-	-	-
Darkstone R11 A+B+C	-	-	0050899	-	-	-	-	-	-
Lightstone R11 A+B+C	-	-	0050869	-	-	-	-	-	-
Pietra di Bavaria R11 A+B+C	-	-	0050839	-	-	-	-	-	-

Imballi / Packing / Verpackungen / Embalajes

Formato	Pezzi/Sc.	Mq/Sc	Sc/Pal	Mq/Pal	Kg/Sc	Kg/Pal
Size	Pcs/Box	Sq. M/Box	Box/Pal	Sq. M/Pal	Kg/Box	Kg/Pal
Größe	Pcs/Ctn	Mq/Ctn	Ctn/Pal	Mq/Pal	Kg/Ctn	Kg/Pal
Format	Stock/Kart	Om/Kart	Kart/Pal	Om/Pal	Kg/Kart	Kg/Pal
Tamaño	Piezas/Caja	Mq/Caja	Caja/Pal	Mq/Pal	Kg/Caja	Kg/Pal
60x120	2	1,44	27	38,88	34,00	918,00
30x120	3	1,08	28	30,24	25,50	714,00
60x60	3	1,08	32	34,56	25,50	816,00
60x60 sp. 20 mm	2	0,72	32	23,04	32,50	1040,00
30x60	6	1,08	32	34,56	25,60	816,00
30x30	11	0,99	40	39,60	22,50	900,00

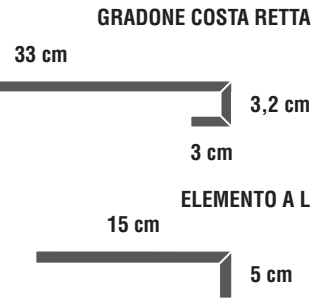

archistone T20 / tech-info

PENDULUM TEST BS 7976

Grip R11 A+B+C > 36 dry / > 36 wet

RESISTENZA ALLA FLESSIONE
FLEXION RESISTANCE

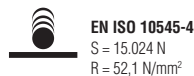

RESISTENZA ALL'URTO
IMPACT RESISTANCE



CARICO STATICO
STATIC LOAD



Posa sopraelevata su supporti regolabili
Installation using adjustable paving support

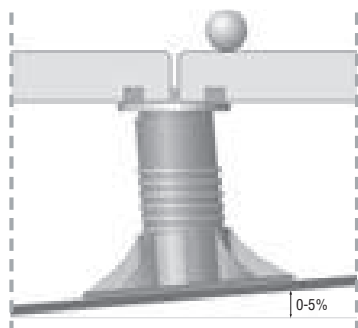

SE

Supporto regolabile con testa autolivellante

Adjustable paving support with self-levelling head



NM

Supporto regolabile

Adjustable paving support



EH

Supporto

Support



SUPPORTI REALIZZATI IN MATERIALE TOTALMENTE RICICLABILE
SUPPORTS MADE FROM 100% RECYCLABLE MATERIAL



RESISTENTI ALLE SOLUZIONI ACIDE E BASICHE
RESISTANT TO ACID AND ALKALI SOLUTIONS



RESISTENTI AGLI AGENTI ATMOSFERICI
RESISTANT TO ATMOSPHERIC AGENTS



RESISTENTI A TEMPERATURE DA -30° A +120°
RESISTANT TO TEMPERATURES FROM -30° TO +120°

2,78 PCS QUANTITÀ M²
PIECES PER M²

Posa diretta su erba

Installation on grass



Posa diretta su erba

Installation on grass



Posa diretta su ghiaia

Installation on gravel



Posa diretta su ghiaia

Installation on gravel

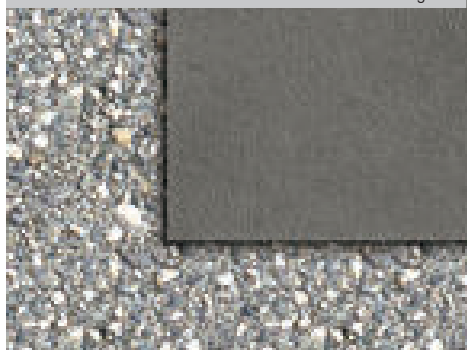

Posa diretta su cemento

Installation on cement

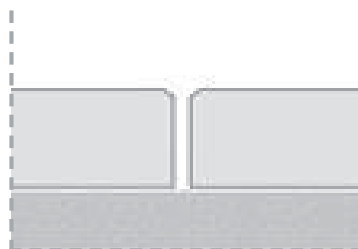

Posa diretta su cemento

Installation on cement

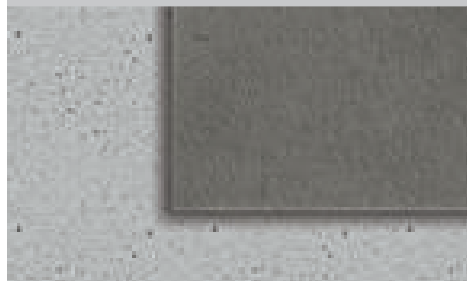

Tipo di supporto	Codice	Altezza supporto
SE1	A004000	da 37,5 a 50 mm
SE2	A004001	da 50 a 75 mm
SE3	A004002	da 75 a 120 mm
SE4	A004003	da 120 a 170 mm
SE5	A004004	da 170 a 215 mm
SE6	A004005	da 140 a 230 mm
SE7	A004006	da 185 a 275 mm
SE8	A004007	da 235 a 325 mm
SE9	A004008	da 205 a 345 mm
SE10	A004009	da 250 a 385 mm
SE11	A004010	da 300 a 400 mm
SE12	A004011	da 270 a 455 mm
SE13	A004012	da 315 a 500 mm
SE14	A004013	da 365 a 550 mm
NM1	A004014	da 25 a 40 mm
NM2	A004015	da 40 a 70 mm
NM3	A004016	da 60 a 100 mm
NM4	A004017	da 90 a 160 mm
NM5	A004018	da 150 a 270 mm
EH12/8	A004019	h 12 mm / ali h 8 mm
EH12	A004020	h 12 mm
EH15	A004021	h 15 mm
EH20	A004022	h 20 mm

Equilibratore basculante
A004023



Spessore livellatore
A004024



blackboard

Gres fine porcellanato / Fine porcelain stoneware / Feinsteinzeug / Grès cérame fin / Gres fino porcelánico **UNI EN 14411 G Bla**



ASH 60x120_24"x48" nat



Formati / Sizes / Grösse / Format / Tamaño:

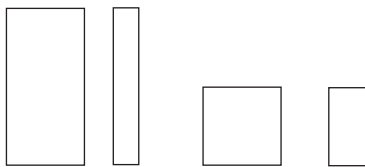

60x120 Rett. 20x120 Rett. 60x60 Rett. 30x60 Rett.
 24"x48" 8"x48" 24"x24" 12"x24"

Superfici / Surface / Oberfläche / Surface / Superficie



NATURALE / NATURAL / NATUR / NATUREL / NATURAL

GRIP / GRIP / GRIP OBERFLÄCHE / GRIP / ANTIDESLIZANTE

blackboard

Gres fine porcellanato / Fine porcelain stoneware / Feinsteinzeug / Grès cérame fin / Gres fino porcelánico **UNI EN 14411 G Bla**



WHITE 20x120_8"x48", 60x120_24"x48" nat / ANTHRACITE 60x60_24"x24" nat



WHITE 60x120_24"x48" nat
ANTHRACITE Lisca diagonale comp. a+b 19,5x47,5_7^{11/16"}x18^{11/16"} nat, Mosaico 5x5 30x30_12"x12" nat

blackboard

Gres fine porcellanato / Fine porcelain stoneware / Feinsteinzeug / Grès cérame fin / Gres fino porcelánico **UNI EN 14411 G Bla**



MUD Lisca diagonale comp. a+b 19,5x47,5_7^{11/16}"x18^{11/16}" nat



blackboard

Gres fine porcellanato / Fine porcelain stoneware / Feinsteinzeug / Grès cérame fin / Gres fino porcelánico **UNI EN 14411 G Bla**

Ash

Anthracite



NATURALE
NATURALE / NATUR / NATUREL / NATURAL

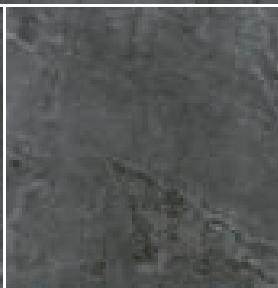
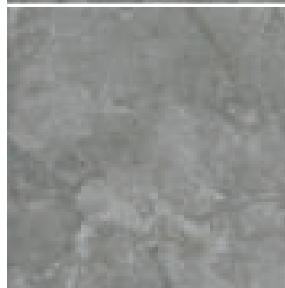

GRIP
GRIP / GRIP OBERFLÄCHE / GRIP / ANTIDESLIZANTE



ASTM C 1028
 Nat > 0,60 dry / > 0,60 wet
 Grip > 0,60 dry / > 0,60 wet



BOT 3000
 ANSI A 137.1:2012
 DCOF ≥ 0,42

PENDULUM
 TEST BS 7876-2:2002
 Grip R11 A+B+C
 > 36 dry / > 36 wet



White

Mud



NATURALE
 NATURAL / NATUR / NATUREL / NATURAL

GRIP
 GRIP / GRIP OBERFLÄCHE / GRIP / ANTIDESLIZANTE

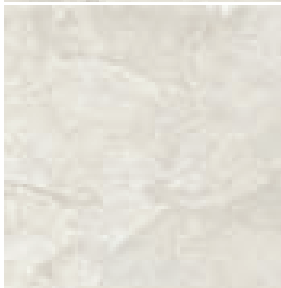

blackboard

Gres fine porcellanato / Fine porcelain stoneware / Feinsteinzeug / Grès cérame fin / Gres fino porcelánico **UNI EN 14411 G Bla**



60x120 Rett.
24"x48"



20x120 Rett.
8"x48"



60x60 Rett.
24"x24"



30x60 Rett.
12"x24"

NATURALE

NATURAL / NATUR / NATUREL / NATURAL

	0052751	0052752	0052756	0052757
Ash				
Anthracite	0052776	0052777	0052781	0052782
White	0052701	0052702	0052706	0052707
Mud	0052726	0052727	0052731	0052732

GRIP

GRIP / GRIP OBERFLÄCHE / GRIP / ANTIDESLIZANTE

Ash	-	-	0052761	0052759
Anthracite	-	-	0052786	0052784
White	-	-	0052711	0052709
Mud	-	-	0052736	0052734



BATTISCOPIA

nat. rett.
7x60
2^{3/4}"x24"



ELEMENTO L

grip rett.
15x60x4
6"x24"x1^{2/3}"



GRAD. LIN. DOPPIA VELA

nat. rett.
33x120x4x2
13"x48"x1^{2/3}"x1^{3/16}"



ANG. GRAD. LIN. DOPPIA VELA SX

nat. rett.
33x120x4x2
13"x48"x1^{2/3}"x1^{3/16}"



ANG. GRAD. LIN. DOPPIA VELA DX

nat. rett.
33x120x4x2
13"x48"x1^{2/3}"x1^{3/16}"

Ash	0052765	0052770	0052766	0052768	0052767
Anthracite	0052790	0052795	0052791	0052793	0052792
White	0052715	0052720	0052716	0052718	0052717
Mud	0052740	0052745	0052741	0052743	0052742

Imballi / Packing / Verpackungen / Emballages / Embalajes

Formato	Pezzi/Sc.	Mq/Sc	Sc/Pal	Mq/Pal	Kg/Sc	Kg/Pal
Size	Pcs/Box	Sq.M/Box	Box/Pal	Sq.M/Pal	Kg/Box	Kg/Pal
Grösse	Pcs/Ctn	Mq/Ctn	Ctn/Pal	Mq/Pal	Kg/Ctn	Kg/Pal
Format	Stck/Kart	Qm/Kart	Kart/Pal	Qm/Pal	Kg/Kart	Kg/Pal
Tamaño	Piezas/Caja	Mq/Caja	Caja/Pal	Mq/Pal	Kg/Caja	Kg/Pal
60x120 nat rett	2	1,44	27	38,88	34	918
20x120 nat rett	5	1,20	27	32,40	28	756
60x60 nat rett / grip rett	3	1,08	32	34,56	25,50	816
30x60 nat rett / grip rett	6	1,08	32	34,56	25,50	816
19,5x47,5 liscia diagonale comp. a+b	6	0,55	30	16,67	17	510
30x60 muretto	4	0,72	30	21,60	17	510
30x30 mosaico 5x5	4	0,36	60	21,60	8,5	510
7x60 battiscopa	14	0,59	63	37,17	15	945
15x60x4 elemento a "L"	4	0,36	30	10,80	12	360
33x120x4x2 gradone lineare doppia vela	2	0,79	-	-	23	-
33x120x4x2 angolo gradone lineare doppia vela	1	0,40	-	-	12	-



ASTM C 1028
 Nat > 0,60 dry / > 0,60 wet
 Grip > 0,60 dry / > 0,60 wet



BOT 3000
 ANSI A 137.1:2012
 DCOF ≥ 0,42

PENDULUM
 TEST BS 7876-2:2002
 Grip R11 A+B+C
 > 36 dry / > 36 wet

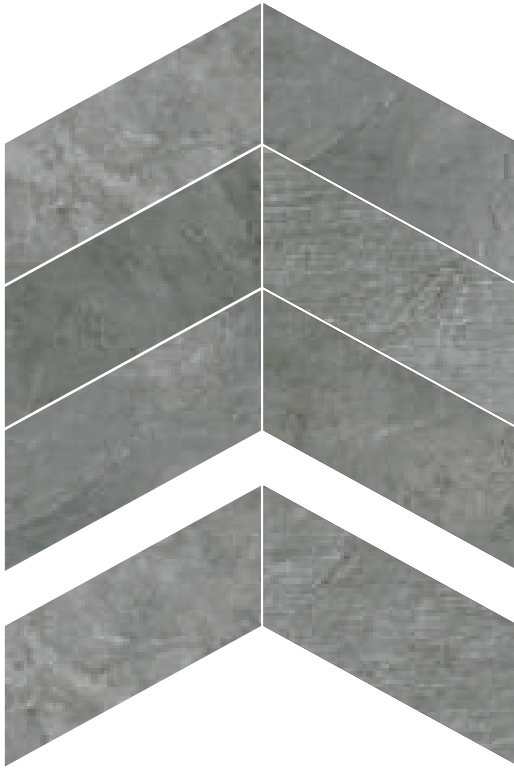

ASH **0052764** Lisca diagonale comp. A+B nat.-rett.
 19,5x47,5 - 7^{11/16}"x18^{11/16}"

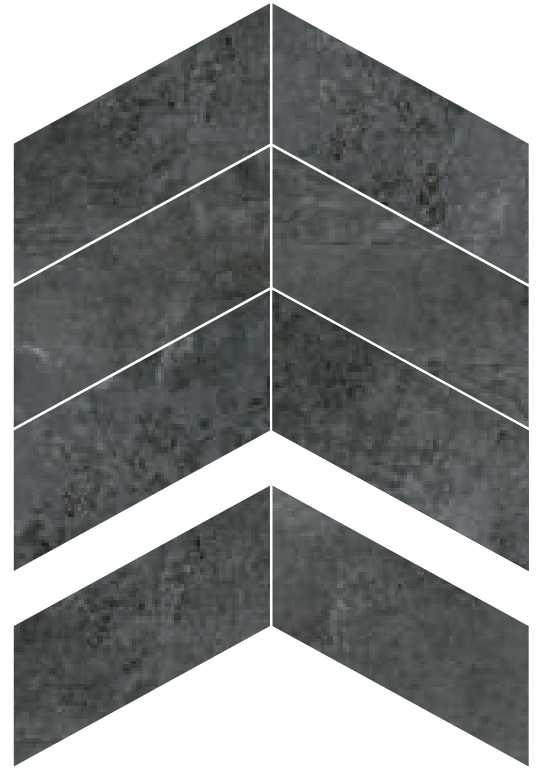

ANTHRACITE **0052789** Lisca diagonale comp. A+B nat.-rett.
 19,5x47,5 - 7^{11/16}"x18^{11/16}"



WHITE **0052714** Lisca diagonale comp. A+B nat.-rett.
 19,5x47,5 - 7^{11/16}"x18^{11/16}"



MUD **0052739** Lisca diagonale comp. A+B nat.-rett.
 19,5x47,5 - 7^{11/16}"x18^{11/16}"

blackboard

Gres fine porcellanato / Fine porcelain stoneware / Feinsteinzeug / Grès cérame fin / Gres fino porcelánico **UNI EN 14411 G Bla**

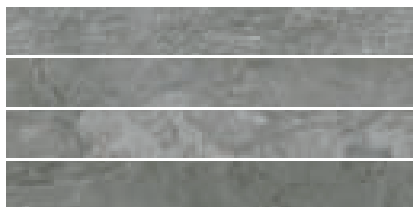

ASH
0052763
Muretto nat.-rett.
30x60 - 12"x24"
4 pcs x box



WHITE
0052713
Muretto nat.-rett.
30x60 - 12"x24"
4 pcs x box

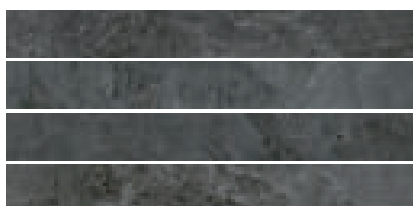

ANTHRACITE
0052788
Muretto nat.-rett.
30x60 - 12"x24"
4 pcs x box

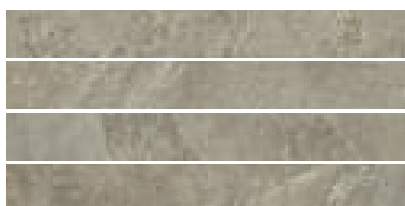

MUD
0052738
Muretto nat.-rett.
30x60 - 12"x24"
4 pcs x box



WHITE 20x120_8"x48" nat











 ASTM C 1028
 Nat > 0,60 dry / > 0,60 wet
 Grip > 0,60 dry / > 0,60 wet

 BOT 3000
 ANSI A 137.1:2012
 DCOF ≥ 0,42

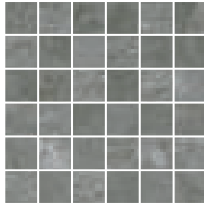
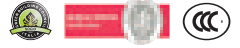
PENDULUM
 TEST BS 7876-2:2002
 Grip R11 A+B+C
 > 36 dry / > 36 wet

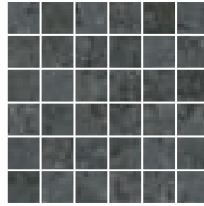

ASH
0052762 Mosaico nat.-rett.
 30x30 - 12"x12" / 5x5 - 2"x2"
 4 pcs x box



ANTHRACITE
0052787 Mosaico nat.-rett.
 30x30 - 12"x12" / 5x5 - 2"x2"
 4 pcs x box



WHITE
0052712 Mosaico nat.-rett.
 30x30 - 12"x12" / 5x5 - 2"x2"
 4 pcs x box

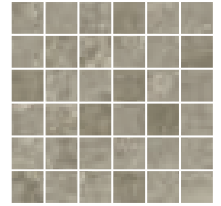

MUD
0052737 Mosaico nat.-rett.
 30x30 - 12"x12" / 5x5 - 2"x2"
 4 pcs x box



MUD 60x120_24"x48", 60x60_24"x24", 30x60_12"x24" nat

dolmen levitas T5,6

Gres fine porcellanato / Fine porcelain stoneware / Feinsteinzeug / Grès cérame fin / Gres fino porcelánico **UNI EN 14411 G Bla**



Beige Nat. Rett. 100x300
Grafite Nat. Rett. 100x300



Formati / Sizes / Grösse / Format / Tamaño:

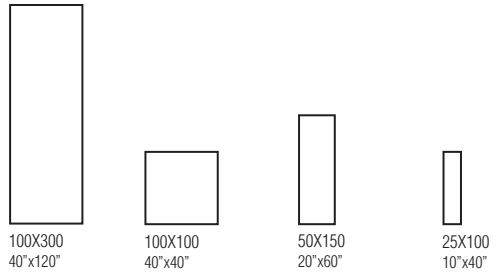

Superfici / Surface / Oberfläche / Surface / Superficie

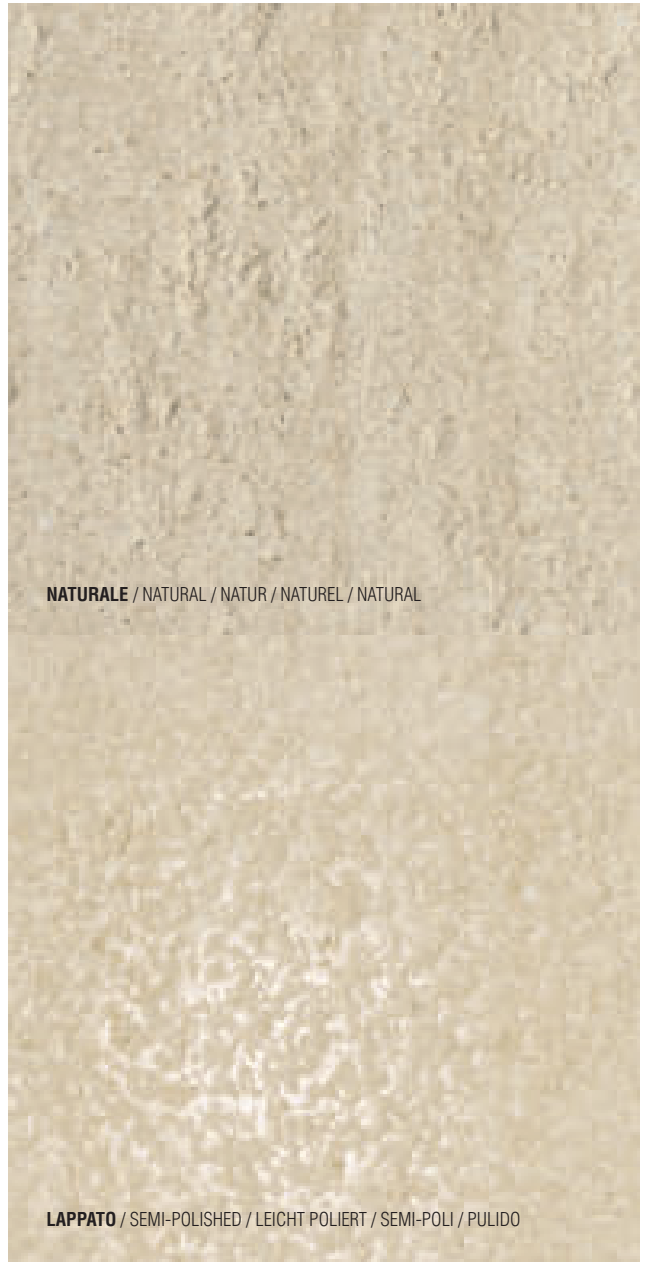

dolmen levitas T5,6

Gres fine porcellanato / Fine porcelain stoneware / Feinsteinzeug / Grès cérame fin / Gres fino porcelánico **UNI EN 14411 G Bla**



Beige Nat. Rett. 100x300
Cenere Nat. Rett. 25x100
Decoro Geometrico Nat. Rett. 25x100
Steam Wood Reddish Brown Nat. Rett. 26,5x180_20x180



Cenere Nat. Rett. 25x100
Cenere Lapp. Rett. 25x100
Decoro Damasque Lapp. Rett. 25x100

dolmen levitas T5,6

Gres fine porcellanato / Fine porcelain stoneware / Feinsteinzeug / Grès cérame fin / Gres fino porcelánico **UNI EN 14411 G Bla**



Bianco Lapp. Rett. 100x100
Beige Nat. Rett. 25x100



Grafite Nat. Rett. 100x100
Bianco Lapp. Rett. 25x100
Decoro Acanthus Lapp. Rett. 25x100

dolmen levitas T5,6

Gres fine porcellanato / Fine porcelain stoneware / Feinsteinzeug / Grès cérame fin / Gres fino porcelánico **UNI EN 14411 G Bla**



Per le modalità di utilizzo, movimentazione, taglio, foratura e posa delle lastre Levitas T5,6 si consiglia di seguire le istruzioni riportate sul relativo Manuale d'uso Levitas T5,6



100x300
40"x120"



100x100
40"x40"



50x150
20"x60"



25x100
10"x40"

NATURALE

NATURAL / NATUR / NATUREL / NATURAL

Beige	0045821	0045825	0045823	0045828
Bianco	0045801	0045805	0045803	0045808
Cenere	0045841	0045845	0045843	0045848
Grafite	0045861	0045865	0045863	0045868

LAPPATO

SEMI-POLISHED / LEICH POLIERT / SEMI-POLI / PULIDO

Beige	0045822	0045827	0045824	0045829
Bianco	0045802	0045807	0045804	0045809
Cenere	0045842	0045847	0045844	0045849
Grafite	0045862	0045867	0045864	0045869

Imballi / Packing / Verpackungen / Emballages / Embalajes

Formato	Pezzi/Sc.	Mq/Sc	Sc/Pal	Mq/Pal	Kg/Sc	Kg/Pal
Size	Pcs/Box	Sq.M/Box	Box/Pal	Sq.M/Pal	Kg/Box	Kg/Pal
Größe	Pcs/Ctn	Mq/Ctn	Ctn/Pal	Mq/Pal	Kg/Ctn	Kg/Pal
Format	Stck/Kart	Qm/Kart	Kart/Pal	Qm/Pal	Kg/Kart	Kg/Pal
Tamaño	Piezas/Caja	Mq/Caja	Caja/Pal	Mq/Pal	Kg/Caja	Kg/Pal
100x300	1	3	13	39	38	494
100x100	2	2	25	50	26	650
50x150	2	1,5	48	72	19	912
25x100	6	1,5	40	60	19	760
25x100 Decori	4	1	16	16	13	208



Cenere Nat. Rett. 25x100

dolmen levitas T5,6

Gres fine porcellanato / Fine porcelain stoneware / Feinsteinzeug / Grès cérame fin / Gres fino porcelánico **UNI EN 14411 G Bla**

Geometrico



0045832 Beige nat. rett.
25x100 - 10"x40"
4 pcs x box



0045812 Bianco nat. rett.
25x100 - 10"x40"
4 pcs x box



0045852 Cenere nat. rett.
25x100 - 10"x40"
4 pcs x box



0045872 Grafite nat. rett.
25x100 - 10"x40"
4 pcs x box

Onda



0045833 Beige nat. rett.
25x100 - 10"x40"
4 pcs x box



0045813 Bianco nat. rett.
25x100 - 10"x40"
4 pcs x box



0045853 Cenere nat. rett.
25x100 - 10"x40"
4 pcs x box



0045873 Grafite nat. rett.
25x100 - 10"x40"
4 pcs x box

Acanthus



0045830 Beige lapp. rett.
25x100 - 10"x40"
4 pcs x box



0045810 Bianco lapp. rett.
25x100 - 10"x40"
4 pcs x box



0045850 Cenere lapp. rett.
25x100 - 10"x40"
4 pcs x box



0045870 Grafite lapp. rett.
25x100 - 10"x40"
4 pcs x box

Damasque



0045831 Beige lapp. rett.
25x100 - 10"x40"
4 pcs x box



0045811 Bianco lapp. rett.
25x100 - 10"x40"
4 pcs x box



0045851 Cenere lapp. rett.
25x100 - 10"x40"
4 pcs x box



0045871 Grafite lapp. rett.
25x100 - 10"x40"
4 pcs x box

ec1

Gres fine porcellanato / Fine porcelain stoneware / Feinsteinzeug / Grès cérame fin / Gres fino porcelánico **UNI EN 14411 G Bla**



Bank SA Strutt. Rett. 60x120
Barbican NE Rett. Lapp. 60x120



Formati / Sizes / Grösse / Format / Tamaño:



60x120 Rett.
24"x48"



60x60 Rett.
24"x24"



30x60 Rett.
12"x24"



10x60 Rett.
4"x24"

Superfici / Surface / Oberfläche / Surface / Superficie

NATURALE / NATURAL / NATUR / NATUREL / NATURAL

STRUTTURATO / TEXTURED / STRUKTURIERTE / STRUCTURÉE / ESTRUCTURADO

LAPPATO / SEMI-POLISHED / LEICHT POLIERT / SEMI-POLI / PULIDO

LEVIGATO / POLISHED / POLIERT / POLI / PULIMENTADO

ec1

Gres fine porcellanato / Fine porcelain stoneware / Feinsteinzeug / Grès cérame fin / Gres fino porcelánico **UNI EN 14411 G Bla**



Farringdon BI Strutt. Rett. 60x120
Farringdon BI Rett. Lev. 60x120
Barbican NE Rett. Lapp. 60x120 / 10x60



ec1

Gres fine porcellanato / Fine porcelain stoneware / Feinsteinzeug / Grès cérame fin / Gres fino porcelánico **UNI EN 14411 G Bla**

Farringdon BI

City AN

Barbican NE

NATURALE
NATURAL / NATUR / NATUREL / NATURAL

STRUTTURATO
TEXTURED / STRUKTURIERTE / STRUCTURÉE / ESTRUCTURADO

LAPPATO
SEMI-POLISHED / LEICHT POLIERT / SEMI-POLI / PULIDO

LEVIGATO
POLISHED / POLIERT / POLI / PULIMENTADO



	Classement				
	U	P	E	C	Gel
60x120 Nat./Strutt./Lapp.	U4	P3	E3	C2	S
60x60 Nat./Strutt./Lapp.	U4	P4+	E3	C2	S
30x60 Nat./Strutt./Lapp.	U4	P4+	E3	C2	S
60x120 - 30x60 - 60x60 Lev.	U3	P3	E3	C2	S



Naturale > 0,60 dry / > 0,60 wet
 Strutturato > 0,60 dry / > 0,60 wet

PENDULUM TEST Naturale > 36 dry / da 25 a 35 wet
 Strutturato > 36 dry / da 25 a 35 wet
 BS 7976

BOT 3000
 ANSI A 137.1:2012
 DCOF ≥ 0,42

Bank SA

Holborn TA

Docks FA

NATURALE
 NATURAL / NATUR / NATUREL / NATURAL

STRUTTURATO
 TEXTURED / STRUKTURIERTE / STRUCTURÉE / ESTRUCTURADO

LAPPATO
 SEMI-POLISHED / LEICHT POLIERT / SEMI-POLI / PULIDO

LEVIGATO
 POLISHED / POLIERT / POLI / PULIMENTADO



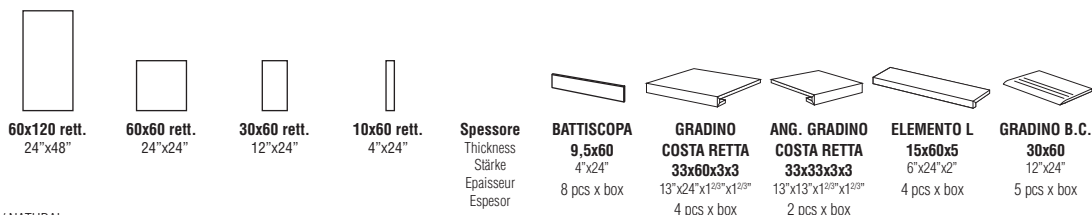

R10
A

NATURALE

NATURAL / NATUR / NATUREL / NATURAL

	60x120 rett. 24"x48"	60x60 rett. 24"x24"	30x60 rett. 12"x24"	10x60 rett. 4"x24"	Spessore Thickness Stärke Epaisseur Espesor	BATTISCOPA 9,5x60 4"x24" 8 pcs x box	GRADINO COSTA RETTA 33x60x3x3 13"x24"x1 ²⁵ "x1 ²⁵ " 4 pcs x box	ANG. GRADINO COSTA RETTA 33x33x3x3 13"x13"x1 ²⁵ "x1 ²⁵ " 2 pcs x box	ELEMENTO L 15x60x5 6"x24"x2" 4 pcs x box	GRADINO B.C. 30x60 12"x24" 5 pcs x box
Farringdon BI	0045001	0045004	0045007	0045014	10,5	0045012	0045030	0045031	0045032	0045035
City AN	0045161	0045164	0045167	0045174	10,5	0045172	0045190	0045191	0045192	0045195
Barbican NE	0045201	0045204	0045207	0045214	10,5	0045212	0045230	0045231	0045232	0045235
Bank SA	0045041	0045044	0045047	0045054	10,5	0045052	0045070	0045071	0045072	0045075
Holborn TA	0045081	0045084	0045087	0045094	10,5	0045092	0045110	0045111	0045112	0045115
Docks FA	0045121	0045124	0045127	0045134	10,5	0045132	0045150	0045151	0045152	0045155

R12
A+B+C

STRUTTURATO

TEXTURED / STRUKTURIERTE / STRUCTURÉE / ESTRUCTURADO

Farringdon BI	0045021	0045022	0045023	0045026	10,5	0045024	-	-	0045033	0045027
City AN	0045181	0045182	0045183	0045186	10,5	0045184	-	-	0045193	0045187
Barbican NE	0045221	0045222	0045223	0045226	10,5	0045224	-	-	0045233	0045227
Bank SA	0045061	0045062	0045063	0045066	10,5	0045064	-	-	0045073	0045067
Holborn TA	0045101	0045102	0045103	0045106	10,5	0045104	-	-	0045113	0045107
Docks FA	0045141	0045142	0045143	0045146	10,5	0045144	-	-	0045153	0045147

LAPPATO

SEMI-POLISHED / LEICHT POLIERT / SEMI-POLI / PULIDO

Farringdon BI	0045002	0045005	0045008	0045015	10,5	0045016	-	-	-	0045036
City AN	0045162	0045165	0045168	0045175	10,5	0045176	-	-	-	0045196
Barbican NE	0045202	0045205	0045208	0045215	10,5	0045216	-	-	-	0045236
Bank SA	0045042	0045045	0045048	0045055	10,5	0045056	-	-	-	0045076
Holborn TA	0045082	0045085	0045088	0045095	10,5	0045096	-	-	-	0045116
Docks FA	0045122	0045125	0045128	0045135	10,5	0045136	-	-	-	0045156

LEVIGATO

POLISHED / POLIERT / POLI / PULIMENTADO

Farringdon BI	0045003	0045006	-	-	10	0045034	-	-	-	0045037
City AN	0045163	0045166	-	-	10	0045194	-	-	-	0045197
Barbican NE	0045203	0045206	-	-	10	0045234	-	-	-	0045237
Bank SA	0045043	0045046	-	-	10	0045074	-	-	-	0045077
Holborn TA	0045083	0045086	-	-	10	0045114	-	-	-	0045117
Docks FA	0045123	0045126	-	-	10	0045154	-	-	-	0045157

GRADONE COSTA RETTA

33 cm



ELEMENTO A L

15 cm



	Classement				
	U	P	E	C	Gel
60x120 Nat./Strutt./Lapp.	U4	P3	E3	C2	S
60x60 Nat./Strutt./Lapp.	U4	P4+	E3	C2	S
30x60 Nat./Strutt./Lapp.	U4	P4+	E3	C2	S
60x120 - 30x60 - 60x60 Lev.	U3	P3	E3	C2	S



Naturale > 0,60 dry / > 0,60 wet
Strutturato > 0,60 dry / > 0,60 wet

PENDULUM Naturale > 36 dry / da 25 a 35 wet
TEST Strutturato > 36 dry / da 25 a 35 wet
BS 7976

BOT 3000
ANSI A 137.1:2012
DCOF ≥ 0,42



0045013 Farrington BI Rett. 15x60 - 6"x24"
6 pcs x box



0045173 City AN Rett. 15x60 - 6"x24"
6 pcs x box

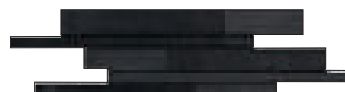

0045213 Barbican NE Rett. 15x60 -6"x24"
6 pcs x box



0045053 Bank SA Rett. 15x60 - 6"x24"
6 pcs x box



0045093 Holborn TA Rett. 15x60 - 6"x24"
6 pcs x box

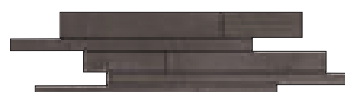

0045133 Docks FA Rett. 15x60 - 6"x24"
6 pcs x box

Imballi / Packing / Verpackungen / Emballages / Embalajes

Formato	Pezzi/Sc.	Mq/Sc	Sc/Pal	Mq/Pal	Kg/Sc	Kg/Pal
Size	Pcs/Box	Sq.M/Box	Box/Pal	Sq.M/Pal	Kg/Box	Kg/Pal
Grösse	Pcs/Ctn	Mq/Ctn	Ctn/Pal	Mq/Pal	Kg/Ctn	Kg/Pal
Format	Stck/Kart	Qm/Kart	Kart/Pal	Qm/Pal	Kg/Kart	Kg/Pal
Tamaño	Piezas/Caja	Mq/Caja	Caja/Pal	Mq/Pal	Kg/Caja	Kg/Pal
60x120	2	1,44	27	38,88	34	918
60x60	3	1,08	32	34,56	25,5	816
30x60	6	1,08	32	34,56	25,3	810
10x60	16	0,96	48	46,08	22,5	1080

Holborn TA Strutt. Rett. 60x120
Holborn TA Fascia Muretto Rett. 15x60
Barbican NE Rett. 60x120
Barbican NE Rett. Lev. 60x60



ec1 levitas T5,6

Gres fine porcellanato / Fine porcelain stoneware / Feinsteinzeug / Grès cérame fin / Gres fino porcelánico **UNI EN 14411 G Bla**



Bank SA Rett. 100x300

100x300

50x150

100x100

Formati / Sizes / Grösse / Format / Tamaño:

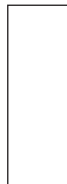

100x300 Rett.
40"x120"



50x150 Rett.
20"x60"



100x100 Rett.
40"x40"

Superfici / Surface / Oberfläche / Surface / Superficie

NATURALE / NATURAL / NATUR / NATUREL / NATURAL

STRUTTURATO / TEXTURED / STRUKTURIERTE / STRUCTURÉE / ESTRUCTURADO

LAPPATO / SEMI-POLISHED / LEICHT POLIERT / SEMI-POLI / PULIDO

ec1 levitas T5,6

Gres fine porcellanato / Fine porcelain stoneware / Feinsteinzeug / Grès cérame fin / Gres fino porcelánico **UNI EN 14411 G Bla**



Farrington BI Lapp. Rett. 100x100



Barbican NE Rett. 100x100
Barbican NE Strutt. Rett. 100x100
Barbican NE Rett. 100x300
Holborn TA Strutt. Rett. 100x300
Holborn TA Rett. 100x300

ec1 levitas T5,6

Gres fine porcellanato / Fine porcelain stoneware / Feinsteinzeug / Grès cérame fin / Gres fino porcelánico **UNI EN 14411 G Bla**



Holborn TA Rett. 100x300
Holborn TA Strutt. Rett. 100x100
Docks FA Strutt. Rett. 50x150
Farringdon BI Rett. 50x150

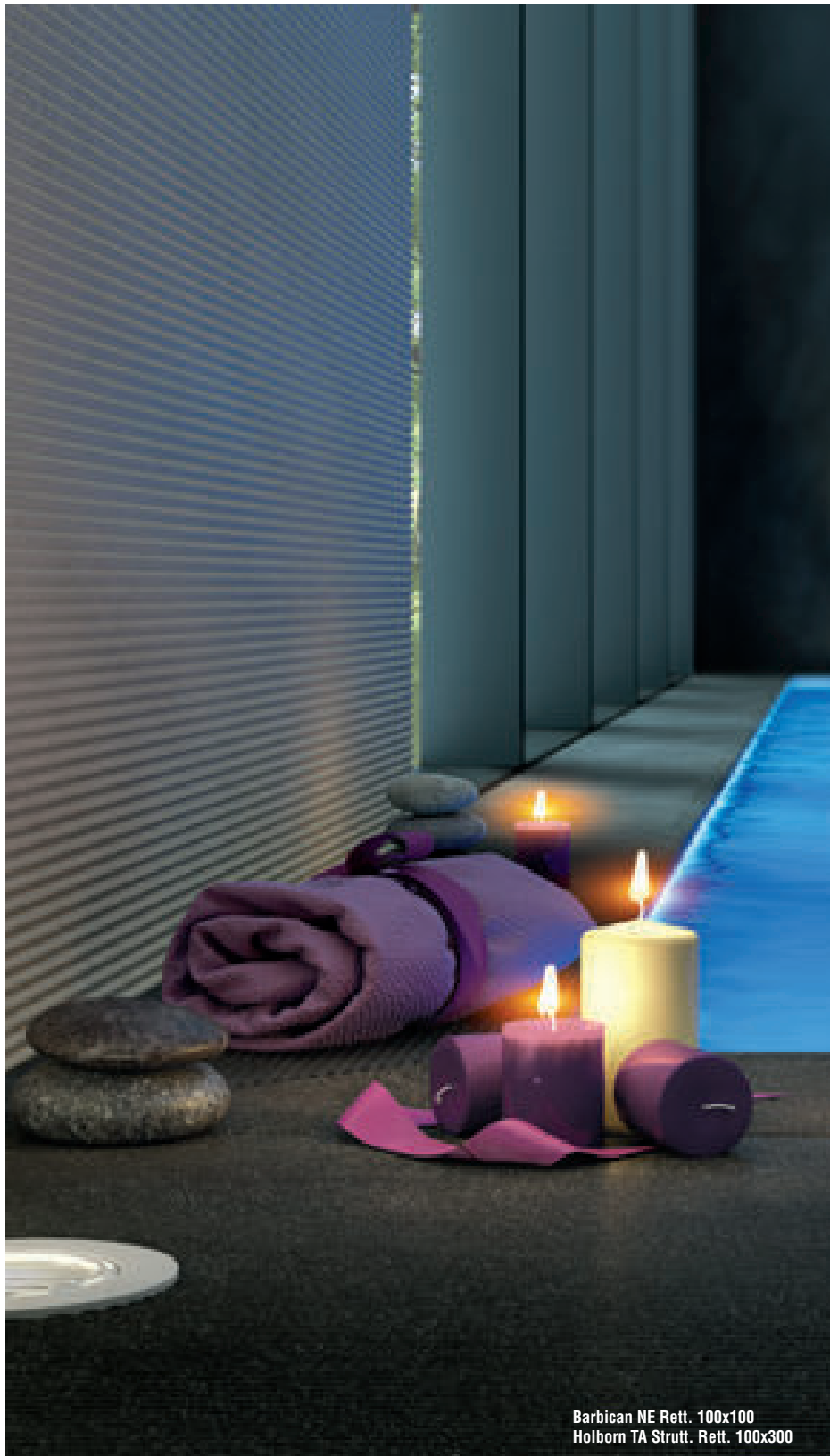

Barbican NE Rett. 100x100
Holborn TA Strutt. Rett. 100x300

ec1 levitas T5,6

Gres fine porcellanato / Fine porcelain stoneware / Feinsteinzeug / Grès cérame fin / Gres fino porcelánico **UNI EN 14411 G BIa**

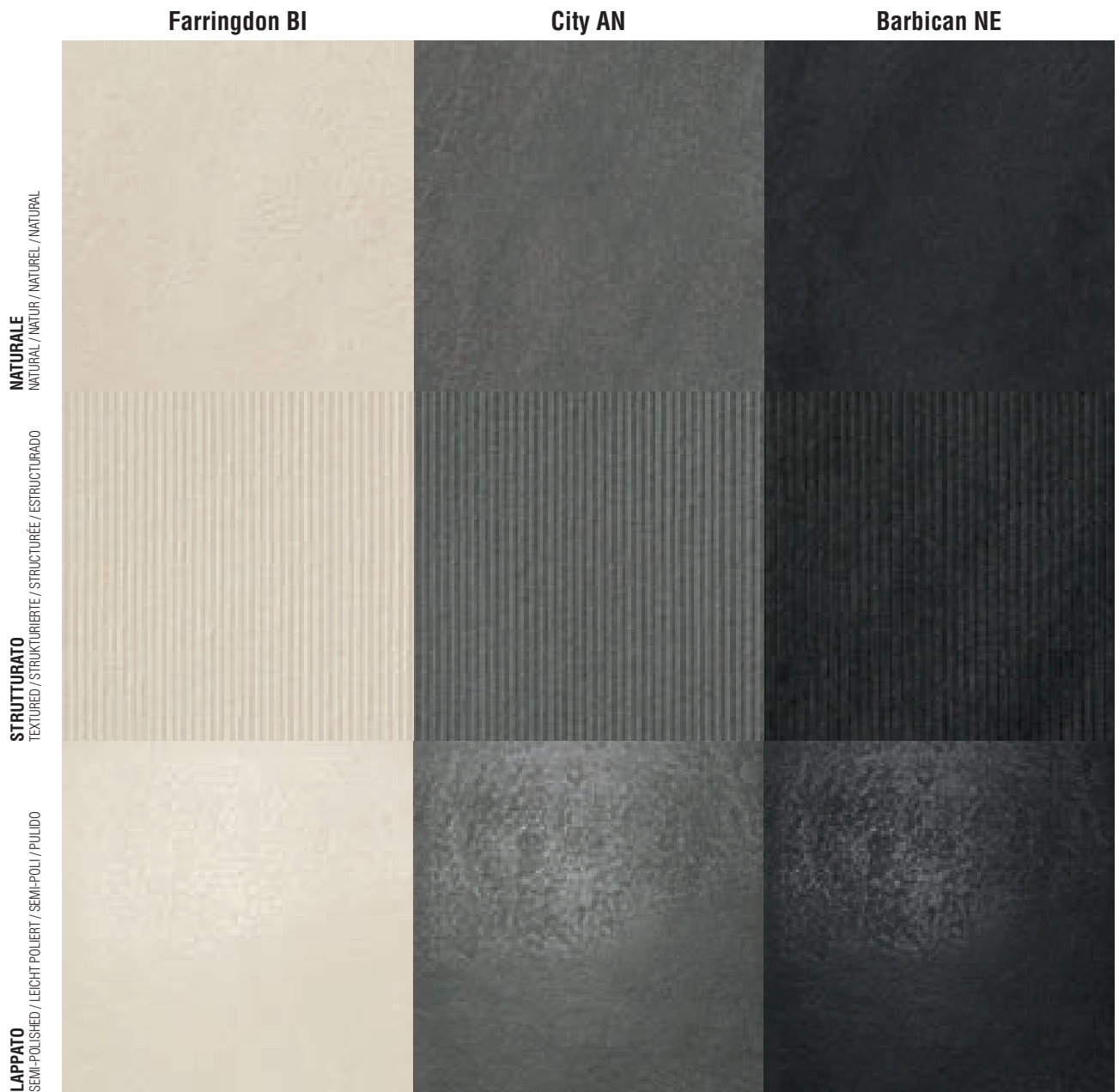

Per le modalità di utilizzo, movimentazione, taglio, foratura e posa delle lastre Levitas T5,6 si consiglia di seguire le istruzioni riportate sul relativo Manuale d'uso Levitas T5,6



Classement

U P E C Gel

100x100 Nat / lap

U4 P3 E3 C2 S



BOT 3000
ANSI A 137.1:2012
DCOF ≥ 0,42

Naturali

Strutt.

Bank SA

Holborn TA

Docks FA

NATURALE
NATURAL / NATUR / NATUREL / NATURAL

STRUTTURATO
TEXTURED / STRUKTURIERTE / STRUCTURÉE / ESTRUCTURADO

LAPPATO
SEMI-POLISHED / LEICHT POLIERT / SEMI-POLI / PULIDO



Per le modalità di utilizzo, movimentazione, taglio, foratura e posa delle lastre Levitas T5,6 si consiglia di seguire le istruzioni riportate sul relativo Manuale d'uso Levitas T5,6

ec1 levitas T5,6

Gres fine porcellanato / Fine porcelain stoneware / Feinsteinzeug / Grès cérame fin / Gres fino porcelánico **UNI EN 14411 G Bia**

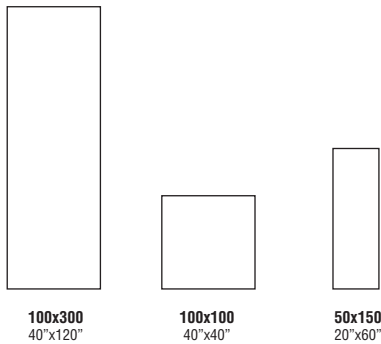

NATURALE

NATURAL / NATUR / NATUREL / NATURAL

Farringdon BI	0045302	0045305	0045308
City AN	0045462	0045465	0045468
Barbican NE	0045502	0045505	0045508
Bank SA	0045342	0045345	0045348
Holborn TA	0045382	0045385	0045388
Docks FA	0045422	0045425	0045428

LAPPATO

SEMI-POLISHED / LEICHT POLIERT / SEMI-POLI / PULIDO

Farringdon BI	0045303	0045306	0045309
City AN	0045463	0045466	0045469
Barbican NE	0045503	0045506	0045509
Bank SA	0045343	0045346	0045349
Holborn TA	0045383	0045386	0045389
Docks FA	0045423	0045426	0045429

STRUTTURATO

TEXTURED / STRUKTURIERTE / STRUCTURÉE / ESTRUCTURADO

Farringdon BI	0045321	0045322	0045323
City AN	0045481	0045482	0045483
Barbican NE	0045521	0045522	0045523
Bank SA	0045361	0045362	0045363
Holborn TA	0045401	0045402	0045403
Docks FA	0045441	0045442	0045443

NORMA UNI EN ISO 10545-4

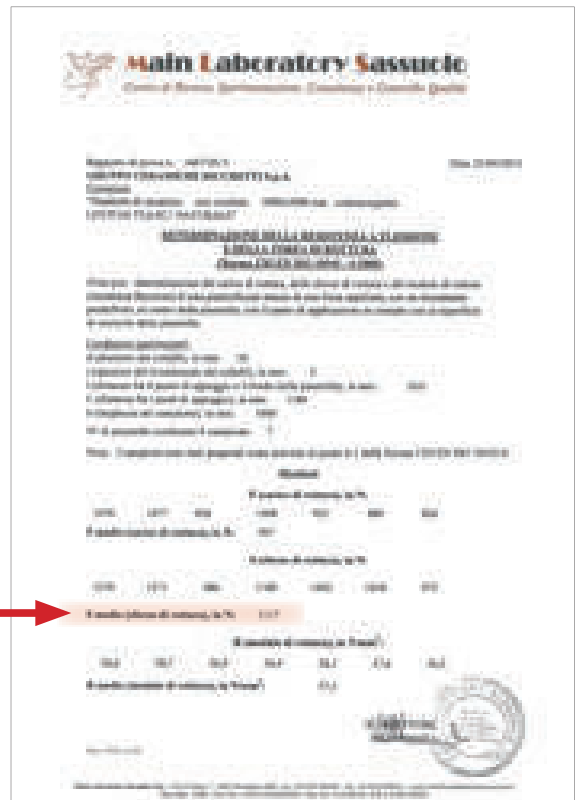

Sforzo di rottura

Breaking strenght / Bruchkraft / Contrainte de rupture / Esfuerzo de rotura

Lo spessore di **5,6 mm** garantisce una giusta proporzione tra



resistenza meccanica



facilità di movimentazione



peso

The thickness of **5,6 mm** ensures the right balance between **mechanical resistance**, **ease of handling** and **weight**.

L'épaisseur de **5,6 mm** assure une bonne proportion au milieu de la **résistance mécanique**, de la **facilité de manipulation** et de **poids**.

Die Dicke von **5,6 mm** versichert ein korrektes Verhältnis zwischen **mechanische Festigkeit**, eine **einfache Handhabung** und **Gewicht**.

El espesor **5,6 mm** asegura una correcta proporción entre la **resistencia mecánica**, **facilidad de manejo** y **peso**.

Imballi / Packing / Verpackungen / Emballages / Embalajes

Formato	Pezzi/Sc.	Pezzi/Pal	Mq/Sc	Sc/Pal	Mq/Pal	Kg/Sc	Kg/Pal
Size	Pcs/Box	Pcs/Pal	Sq.M/Box	Box/Pal	Sq.M/Pal	Kg/Box	Kg/Pal
Größe	Pcs/Ctn	Pcs/Pal	Mq/Ctn	Ctn/Pal	Mq/Pal	Kg/Ctn	Kg/Pal
Format	Stck/Kart	Stck/Pal	Qm/Kart	Kart/Pal	Qm/Pal	Kg/Kart	Kg/Pal
Tamaño	Piezas/Caja	Piezas/Pal	Mq/Caja	Caja/Pal	Mq/Pal	Kg/Caja	Kg/Pal
100x300	-	13	-	-	39 (13 pz)	37,7	490,1
100x100	2	50	2,0	25	50	27,2	680,0
50x150	2	96	1,5	48	72	20,7	993,6

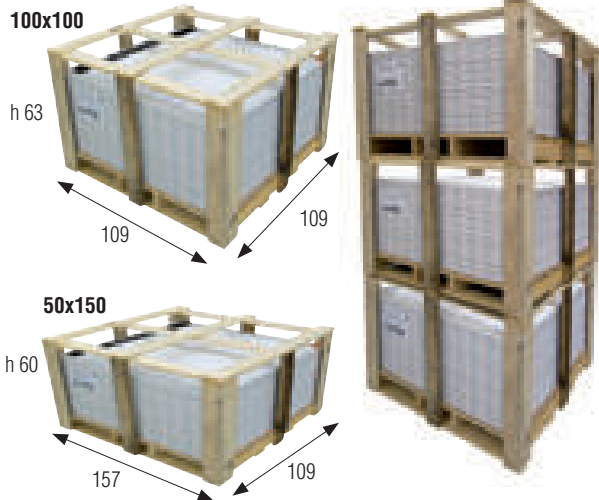
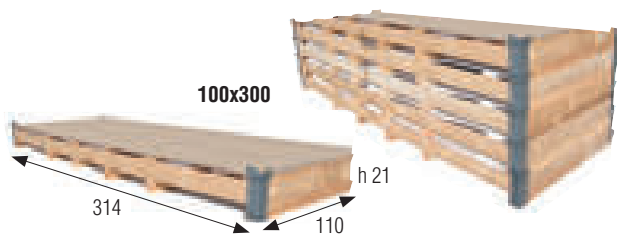

I formati 100x300 sono imballati accuratamente in vassoi di legno sovrapponibili (314x110x21 cm) studiati per garantire l'integrità del prodotto (massimo 4 vassoi in colonna)*

Il formato 100x100 e 50x150 sono imballati in fustelle di cartone collocate su appositi pallet sovrapponibili (109x109xh63 cm e 109x157xh60 cm)**

*Sizes 100x300 are carefully packaged on wooden crates that can be overlapped (314x110x21 cm), suitably designed for a damage-free delivery. (max 4 crates overlapping).

**Size 100x100 and 50x150 are packaged in cardboard sheets placed on suitable pallets that can be overlapped (109x109xh63 cm and 109x157xh60 cm).

*Formate 100x300 sind sorgfältig in stapelbaren Holzkisten (max. 4 Holzkisten hoch) verpackt, die derart entworfen sind, so dass dieses Produkt ohne Schaden transportiert werden kann.

**Im Format 100x100 und 50x150 und in den kleineren Unterformaten werden Cerdisa Keramikplatten in Stanzkartons auf stapelbaren Paletten verpackt. (109x109xh63 cm und 109x157xh60 cm).

*Les formats 100x300 sont emballés dans des plateaux en bois (314x110x21 cm) étudiés pour garantir l'intégrité du produit (il est possible empiler les plateaux formant une colonne de maximum 4 plateaux).

**Le format 100x100 e 50x150 sont emballés dans des découpes en carton placées sur des palettes superposables ad hoc (109x109xh63 cm et 109x157xh60).



City AN Lapp. Rett. 100x300
Farringdon BI Lapp. Rett. 100x100

formwork

Gres fine porcellanato / Fine porcelain stoneware / Feinsteinzeug / Grès cérame fin / Gres fino porcelánico **UNI EN 14411 G Bla**



Ash Nat. Rett. 30x120
Gainsboro Nat. Rett. 30x120
Decoro Geometrico Grigio 30x30
Decoro Geometrico Mix Rosso/Grigio 30x120
Decoro Geometrico Rosso 30x120



Formati / Sizes / Grösse / Format / Tamaño:



60x120 Rett.
24"x48"



30x120 Rett.
12"x48"



15x120 Rett.
6"x48"



40x80 Rett.
16"x32"



20x80 Rett.
8"x32"

Superfici / Surface / Oberfläche / Surface / Superficie

NATURALE / NATURAL / NATUR / NATUREL / NATURAL

LAPPATO / SEMI-POLISHED / LEICHT POLIERT / SEMI-POLI / PULIDO

GRIP / GRIP / GRIP OBERFLÄCHE / GRIP / ANTIDESLIZANTE

formwork

Gres fine porcellanato / Fine porcelain stoneware / Feinsteinzeug / Grès cérame fin / Gres fino porcelánico **UNI EN 14411 G Bla**

White

Gainsboro

Ash

NATURALE
NATURAL / NATUR / NATUREL / NATURAL

LAPPATO
SEMI-POLISHED / LEICHT POLIERT / SEMI-POLI / PULIDO

GRIP
GRIP / GRIP OBERFLÄCHE / GRIP / ANTIDESLIZANTE



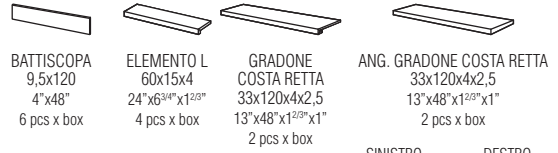
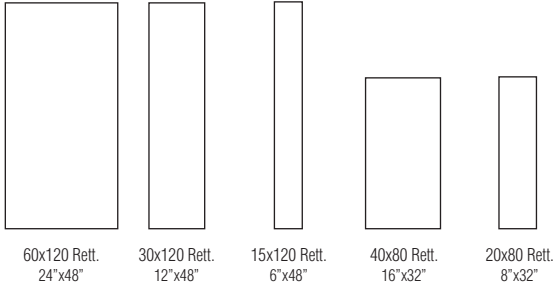

NATURALE

NATURAL / NATUR / NATUREL / NATURAL

White	0051101	0051102	0051103	0051301	0051302
Gainsboro	0051201	0051202	0051203	0051401	0051402
Ash	0051231	0051232	0051233	0051431	0051432

LAPPATO

SEMI-POLISHED / LEICHT POLIERT / SEMI-POLI / PULIDO

White	0051104	0051105	0051106	0051303	0051304
Gainsboro	0051204	0051205	0051206	0051403	0051404
Ash	0051234	0051235	0051236	0051433	0051434

GRIP

GRIP / GRIP OBERFLÄCHE / GRIP / ANTIDSLIZANTE

White	0051137	0051138	0051139	0051337	0051338
Gainsboro	0051227	0051228	0051229	0051427	0051428
Ash	0051257	0051258	0051259	0051457	0051458

0051550	-	0051530	0051520	0051540
0051553	-	0051533	0051523	0051543
0051554	-	0051534	0051524	0051544

0051640	-	-	-	-
0051643	-	-	-	-
0051644	-	-	-	-

-	0051590	-	-	-
-	0051593	-	-	-
-	0051594	-	-	-

ELEMENTO A L



GRADONE COSTA RETTA

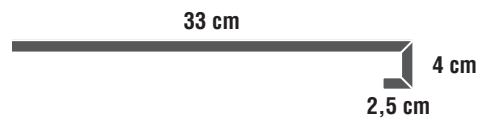

Imballi / Packing / Verpackungen / Emballages / Embalajes

Formato	Pezzi/Sc.	Mq/Sc	Sc/Pal	Mq/Pal	Kg/Sc	Kg/Pal
Size	Pcs/Box	Sq.M/Box	Box/Pal	Sq.M/Pal	Kg/Box	Kg/Pal
Grösse	Pcs/Ctn	Mq/Ctn	Ctn/Pal	Mq/Pal	Kg/Ctn	Kg/Pal
Format	Stck/Kart	Qm/Kart	Kart/Pal	Qm/Pal	Kg/Kart	Kg/Pal
Tamaño	Piezas/Caja	Mq/Caja	Caja/Pal	Mq/Pal	Kg/Caja	Kg/Pal
60x120	2	1,44	27	38,88	34,00	918,00
30x120	3	1,08	28	30,24	25,50	714,00
15x120	6	1,08	28	30,24	25,50	714,00
40x80	3	0,96	56	53,76	23,70	1327,20
20x80	7	1,12	48	53,76	27,50	1320,00

formwork

Gres fine porcellanato / Fine porcelain stoneware / Feinsteinzeug / Grès cérame fin / Gres fino porcelánico **UNI EN 14411 G Bla**

DECORO GEOMETRICO 30x30*

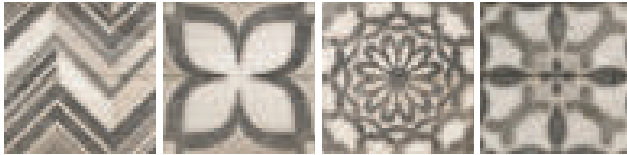

Decoro Geometrico Grigio Rett.
30x30 - 12"x12" / 4 mixed pcs x box
0051626

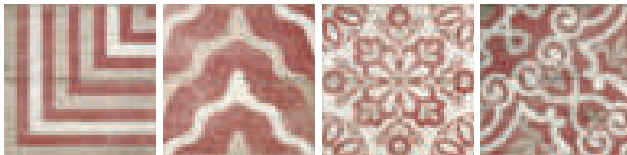

Decoro Geometrico Rosso Rett.
30x30 - 12"x12" / 4 mixed pcs x box
0051625



Decoro Geometrico Mix Rosso/Grigio Rett.
30x30 - 12"x12" / 4 mixed pcs x box
0051627

LISTONE GEOMETRICO 30x120



Listone Geometrico Grigio Rett.
30x120 - 12"x48" / 2 pcs x box
0051623



Listone Geometrico Rosso Rett.
30x120 - 12"x48" / 2 pcs x box
0051622

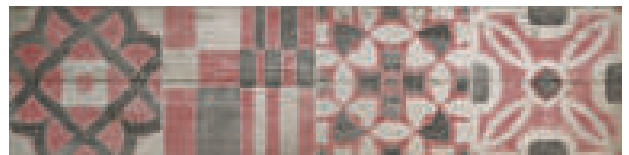

Listone Geometrico Mix Rosso/Grigio Rett.
30x120 - 12"x48" / 2 pcs x box
0051624

*** Tutti i decori GEOMETRICI 30x30 sono
inscatolati mescolando in maniera casuale
i disegni della piastrella.**

* All the GEOMETRICI 30x30 decoratives pieces are boxed randomly to mix the patterns on the tiles.

* Beim Verpacken aller Dekore GEOMETRICI 30x30 wurden die Zeichnungen der Fliese nach dem Zufallsprinzip gemischt.

* Tous les décors GEOMETRICI 30x30 sont mis en boîte en mélangant de manière aléatoire les motifs du carrelage.

* Todas las decoraciones GEOMETRICI 30x30 se presentan en estuches con los dibujos de la baldosa mezclados al azar.



Gainsboro Nat. Rett. 30x120
Decoro Geometrico Mix Rosso/Grigio 30x120
Decoro Geometrico Rosso 30x120

MOSAICO SFALSATO 30x60

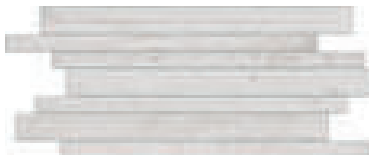

Mosaico Sfalsato White Nat.
30x60 - 12"x24" / 4 pcs x box
0051610



Mosaico Sfalsato Gainsboro Nat.
30x60 - 12"x24" / 4 pcs x box
0051613



Mosaico Sfalsato Ash Nat.
30x60 - 12"x24" / 4 pcs x box
0051614

MOSAICO 30x30

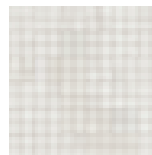

Mosaico White Nat.
30x30 - 12"x12" / 4 pcs x box
0051600



Mosaico Gainsboro Nat.
30x30 - 12"x12" / 4 pcs x box
0051603



Mosaico Ash Nat.
30x30 - 12"x12" / 4 pcs x box
0051604



Ash Nat. Rett. 60x120
White Nat. Rett. 30x120
Mosaico White 30x30

portland

Gres fine porcellanato / Fine porcelain stoneware / Feinsteinzeug / Grès cérame fin / Gres fino porcelánico **UNI EN 14411 G Bla**



Grigio Scuro Rett. Lapp. 60x60



Formati / Sizes / Grösse / Format / Tamaño:



60,8x60,8
59,8x59,8 Rett.
24"x24"



30x60
30x60 Rett.
12"x24"



15x60 Rett.
6"x24"

Superfici / Surface / Oberfläche / Surface / Superficie



NATURALE / NATURAL / NATUR / NATUREL / NATURAL



LAPPATO / SEMI-POLISHED / LEICHT POLIERT / SEMI-POLI / PULIDO

portland

Gres fine porcellanato / Fine porcelain stoneware / Feinsteinzeug / Grès cérame fin / Gres fino porcelánico **UNI EN 14411 G Bla**



Tortora Rett. Lapp. 60x60



Classement

U P E C Gel

30x60 Nat./Lapp.	U4	P4	E3	C2	S
60x60 Nat./Lapp.	U4	P4+	E3	C2	S



60,8x60,8
59,8x59,8



30x60
15x60



portland

Gres fine porcellanato / Fine porcelain stoneware / Feinsteinzeug / Grès cérame fin / Gres fino porcelánico **UNI EN 14411 G Bla**

Avorio

Grigio Chiaro

Grigio Azzurro

Grigio Scuro



NATURALE
NATURAL / NATUR / NATUREL / NATURAL

LAPPATO
SEMI-POLISHED / LEICHT POLIERT / SEMI-POLI / PULIDO



60,8x60,8
24"x24"

10,5



60x60 rett.
24"x24"

10,5



30x60
12"x24"

9,5



30x60 rett.
12"x24"

9,5



15x60 rett.
6"x24"

9,5

NATURALE

NATURAL / NATUR / NATUREL / NATURAL

Avorio	0050196	0050197	0077896	0077897	-
Grigio Chiaro	0050171	0050181	0077536	0077601	-
Grigio Azzurro	0050172	0050182	0077537	0077602	-
Grigio Scuro	0050190	0050191	0077890	0077891	-
Beige	0050170	0050180	0077535	0077600	-
Tortora	0050193	0050194	0077893	0077894	-
Bronzo	0050173	0050183	0077538	0077603	-

LAPPATO

SEMI-POLISHED / LEICHT POLIERT / SEMI-POLI / PULIDO

Avorio	-	0050198	-	0077898	-
Grigio Chiaro	-	0050186	-	0077611	0077609
Grigio Azzurro	-	0050187	-	0077612	0077614
Grigio Scuro	-	0050192	-	0077892	-
Beige	-	0050185	-	0077610	0077604
Tortora	-	0050195	-	0077895	-
Bronzo	-	0050188	-	0077613	0077619



Classement

U P E C Gel

30x60 Nat./Lapp.	U4	P4	E3	C2	S
60x60 Nat./Lapp.	U4	P4+	E3	C2	S



60,8x60,8
59,8x59,8



30x60
15x60



Beige

Tortora

Bronzo



NATURALE
NATURAL / NATUR / NATUREL / NATURAL

LAPPATO
SEMI-POLISHED / LEICHT POLIERT / SEMI-POLI / PULIDO



BATTISCOPA
9,5x60,8
37/8" x 24"
8 pcs x box



BATT. RETT.
LAPP.
9,5x59,8
37/8" x 24"
8 pcs x box



GRADONE
INCISO
30x30
12" x 12"
13 pcs x box

Avorio	0050164	0050167	0077628
Grigio Chiaro	0050168	0050169	0077621
Grigio Azzurro	0050184	0050199	0077622
Grigio Scuro	0050162	0050165	0077626
Beige	0050218	0050279	0077620
Tortora	0050163	0050166	0077627
Bronzo	0050248	0050289	0077623

Imballi / Packing / Verpackungen / Emballages / Embalajes

Formato	Pezzi/Sc.	Mq/Sc	Sc/Pal	Mq/Pal	Kg/Sc	Kg/Pal
Size	Pcs/Box	Sq.M/Box	Box/Pal	Sq.M/Pal	Kg/Box	Kg/Pal
Grösse	Pcs/Ctn	Mq/Ctn	Ctn/Pal	Mq/Pal	Kg/Ctn	Kg/Pal
Format	Stck/Kart	Qm/Kart	Kart/Pal	Qm/Pal	Kg/Kart	Kg/Pal
Tamaño	Piezas/Caja	Mq/Caja	Caja/Pal	Mq/Pal	Kg/Caja	Kg/Pal
60,8x60,8	3	1,11	32	35,52	26,20	838,40
60x60 Rett.	3	1,08	32	34,56	25,50	816,00
30x60	8	1,44	32	46,08	31,00	992,00
30x60 Rett.	6	1,08	40	43,20	22,50	900,00
15x60 Rett.	11	1,00	33	33,00	21,90	722,70

puntozero

Gres fine porcellanato / Fine porcelain stoneware / Feinsteinzeug / Grès cérame fin / Gres fino porcelánico **UNI EN 14411 G Bla**



Corda Lapp. Rett. 80x80
Rosone Caldo 55x47



Formati / Sizes / Grösse / Format / Tamaño:



60x120 Rett.
24"x48"



20x120 Rett.
8"x48"

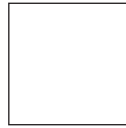

80x80 Rett.
32"x32"



60x60 Rett.
24"x24"



30x60 Rett.
12"x24"

Superfici / Surface / Oberfläche / Surface / Superficie

NATURALE / NATURAL / NATUR / NATUREL / NATURAL

LAPPATO / SEMI-POLISHED / LEICHT POLIERT / SEMI-POLI / PULIDO

GRIP / GRIP / GRIP OBERFLÄCHE / GRIP / ANTIDESLIZANTE

puntozero

Gres fine porcellanato / Fine porcelain stoneware / Feinsteinzeug / Grès cérame fin / Gres fino porcelánico **UNI EN 14411 G Bla**



Biscotto Nat. Rett. 60x120_ 20x120
Riso Mosaico 30x30
Dolmen Levitas Grafite Nat. Rett. 100x300



Cenere
Listello 3 pezzi freddo 15x60
Gradone lineare doppia vela Nat. Rett. 33x120x4x2

puntozero

Gres fine porcellanato / Fine porcelain stoneware / Feinsteinzeug / Grès cérame fin / Gres fino porcelánico **UNI EN 14411 G Bla**

Latte

Nuvola

Cenere

NATURALE
NATURAL / NATUR / NATUREL / NATURAL

LAPPATO
SEMI-POLISHED / LEICHT POLIERT / SEMI-POLI / PULIDO

GRIP
GRIP / GRIP OBERFLÄCHE / GRIP / ANTIDESLIZANTE





ASTM C 1028
 Nat > 0,60 dry / > 0,60 wet
 Grip > 0,60 dry / > 0,60 wet

PENDULUM
 TEST BS 7976
 Grip R11 A+B+C
 > 36 dry / > 36 wet



BOT 3000
 ANSI A 137.1:2012
 DCOF ≥ 0,42



Riso

Corda

Biscotto

NATURALE
 NATURAL / NATUR / NATUREL / NATURAL

LAPPATO
 SEMI-POLISHED / LEICHT POLIERT / SEMI-POLI / PULIDO

GRIP
 GRIP / GRIP OBERFLÄCHE / GRIP / ANTIDESLIZANTE



puntozero

Gres fine porcellanato / Fine porcelain stoneware / Feinsteinzeug / Grès cérame fin / Gres fino porcelánico **UNI EN 14411 G Bia**



60x120 Rett.
24"x48"



20x120 Rett.
8"x48"



80x80 Rett.
32"x32"



60x60 Rett.
24"x24"



30x60 Rett.
12"x24"

NATURALE

NATURAL / NATUR / NATUREL / NATURAL

Latte	0051707	0051708	0051702	0051717	0051718
Nuvola	0051836	0051837	0051831	0051846	0051847
Genere	0051866	0051867	0051861	0051876	0051877
Riso	0051737	0051738	0051732	0051747	0051748
Corda	0051767	0051768	0051762	0051777	0051778
Biscotto	0051806	0051807	0051801	0051816	0051817

LAPPATO

SEMI-POLISHED / LEICHT POLIERT / SEMI-POLI / PULIDO

Latte	0051709	0051710	0051703	0051721	-
Nuvola	0051838	0051839	0051832	0051850	-
Genere	0051868	0051869	0051862	0051880	-
Riso	0051739	0051740	0051733	0051751	-
Corda	0051769	0051770	0051763	0051781	-
Biscotto	0051808	0051809	0051802	0051820	-

GRIP

GRIP / GRIP OBERFLÄCHE / GRIP / ANTIDESLIZANTE

Latte	0051714	0051729	-	0051727	-
Nuvola	0051843	0051858	-	0051856	-
Genere	0051873	0051888	-	0051886	-
Riso	0051744	0051759	-	0051757	-
Corda	0051774	0051789	-	0051787	-
Biscotto	0051813	0051828	-	0051826	-



BATTISCOPA

nat. rett.
8x80
3"x32"



BATTISCOPA

lapp. rett.
8x80
3"x32"



BATTISCOPA

nat. rett.
7x60
2^{3/4}"x24"



BATTISCOPA

lapp. rett.
7x60
2^{3/4}"x24"



ELEMENTO L

grip rett.
15x60x5
6"x24"x2"



GRAD. LIN.
DOPPIA VELA

nat. rett.
33x120x4x2
13"x48"x1^{1/2}"x24"



ANG. GRAD. LIN.
DOPPIA VELA

nat. rett.
SX 33x120x4x2
13"x48"x1^{1/2}"x24"



ANG. GRAD. LIN.
DOPPIA VELA

nat. rett.
DX 33x120x4x2
13"x48"x1^{1/2}"x24"

Latte	0051704	0051705	0051891	0051892	0051728	0051711	0051715	0051712
Nuvola	0051833	0051834	0051859	0051893	0051857	0051840	0051844	0051841
Genere	0051863	0051864	0051889	0051890	0051887	0051870	0051874	0051871
Riso	0051734	0051735	0051792	0051793	0051758	0051741	0051745	0051742
Corda	0051764	0051765	0051790	0051791	0051788	0051771	0051775	0051772
Biscotto	0051803	0051804	0051829	0051794	0051827	0051810	0051814	0051811



ASTM C 1028
 Nat > 0,60 dry / > 0,60 wet
 Grip > 0,60 dry / > 0,60 wet

PENDULUM
 TEST BS 7976
 Grip R11 A+B+C
 > 36 dry / > 36 wet



BOT 3000
 ANSI A 137.1:2012
 DCOF ≥ 0,42



ROSONE

51849 - Freddo - 55x47 - 22"x18"3/4

51780 - Caldo - 55x47 - 22"x18"3/4

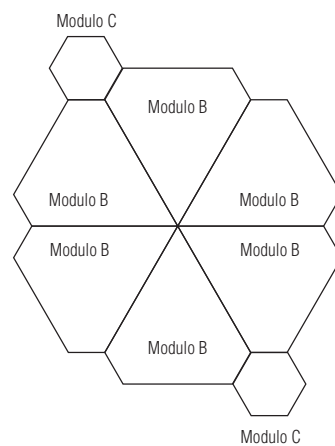
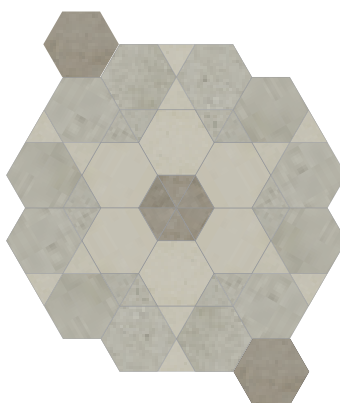
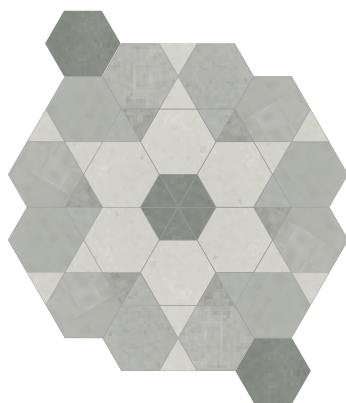
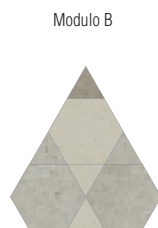
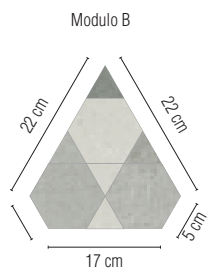

Corda 80x80 lapp. rett.
 Rosone Caldo 55x47

puntozero

Gres fine porcellanato / Fine porcelain stoneware / Feinsteinzeug / Grès cérame fin / Gres fino porcelánico **UNI EN 14411 G Bla**

GEODECORO



51879 - 80x80 - 32"x32" Freddo (Latte, Nuvola, Cenere)



51819 - 80x80 - 32"x32" Caldo (Biscotto, Corda, Riso)

LISTELLO 3 PEZZI

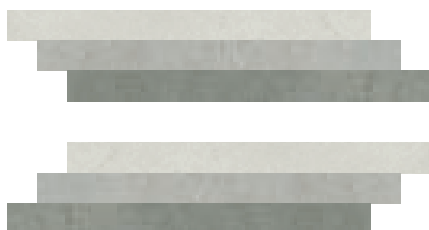

51720 - 15x60 - 6"x24" Freddo - Composizione A+B

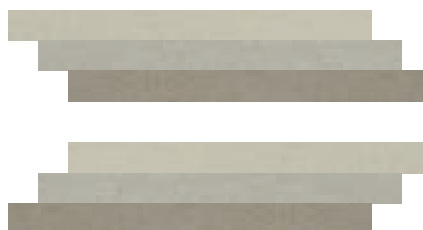

51750 - 15x60 - 6"x24" Caldo - Composizione A+B

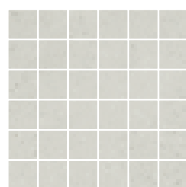

Latte
0051724 Mosaico Naturale
0051725 Mosaico Lappato
30x30 - 12"x12" / 5x5 - 2"x2"
4 pcs x box



Nuvola
0051853 Mosaico Naturale
0051854 Mosaico Lappato
30x30 - 12"x12" / 5x5 - 2"x2"
4 pcs x box

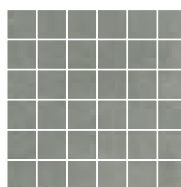

Cenere
0051883 Mosaico Naturale
0051884 Mosaico Lappato
30x30 - 12"x12" / 5x5 - 2"x2"
4 pcs x box

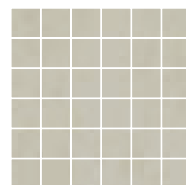

Riso
0051754 Mosaico Naturale
0051755 Mosaico Lappato
30x30 - 12"x12" / 5x5 - 2"x2"
4 pcs x box

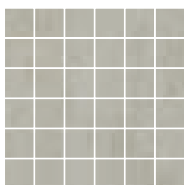

Corda
0051784 Mosaico Naturale
0051785 Mosaico Lappato
30x30 - 12"x12" / 5x5 - 2"x2"
4 pcs x box

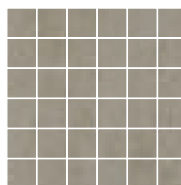

Biscotto
0051823 Mosaico Naturale
0051824 Mosaico Lappato
30x30 - 12"x12" / 5x5 - 2"x2"
4 pcs x box

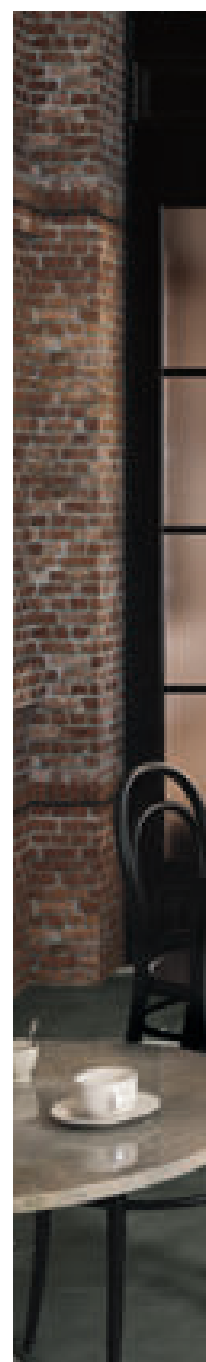



ASTM C 1028
Nat > 0,60 dry / > 0,60 wet
Grip > 0,60 dry / > 0,60 wet

PENDULUM
TEST BS 7976
Grip R11 A+B+C
> 36 dry / > 36 wet



BOT 3000
ANSI A 137.1:2012
DCOF ≥ 0,42



Imballi / Packing / Verpackungen / Emballages / Embalajes

Formato	Pezzi/Sc.	Mq/Sc	Sc/Pal	Mq/Pal	Kg/Sc	Kg/Pal
Size	Pcs/Box	Sq./M/Box	Box/Pal	Sq./M/Pal	Kg/Box	Kg/Pal
Größe	Pcs/Ctn	Mq/Ctn	Ctn/Pal	Mq/Pal	Kg/Ctn	Kg/Pal
Format	Stck/Kart	Qm/Kart	Kart/Pal	Qm/Pal	Kg/Kart	Kg/Pal
Tamaño	Piezas/Caja	Mq/Caja	Caja/Pal	Mq/Pal	Kg/Caja	Kg/Pal
60x120 nat rett / lapp rett / grip rett	2	1,44	27	38,88	34	918
20x120 nat rett / lapp rett / grip rett	5	1,2	27	32,4	28	756
60x60 nat rett / lapp rett / grip rett	3	1,08	32	34,56	25,5	816
30x60 nat rett	6	1,08	32	34,56	25,5	816
80x80 nat rett / lapp rett	2	1,28	40	51,2	30	1200



Cenere 80x80 nat. rett.
Listello 3 prezzi freddo 15x60
Gradone lineare doppia vela 33x120x4x2 nat. rett.

reden

Gres fine porcellanato / Fine porcelain stoneware / Feinsteinzeug / Grès cérame fin / Gres fino porcelánico **UNI EN 14411 G Bla**



GREY 80x80_32"x32" lap / Esagone 30x37_12"x14^{9/16}" nat



Formati / Sizes / Grösse / Format / Tamaño:

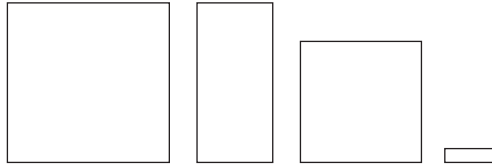

80x80 Rett.
32"x32"

40x80 Rett.
16"x32"

60x60 Rett.
24"x24"

7,5x25
3"x9¹⁶"

Superfici / Surface / Oberfläche / Surface / Superficie

NATURALE / NATURAL / NATUR / NATUREL / NATURAL

LAPPATO / SEMI-POLISHED / LEICHT POLIERT / SEMI-POLI / PULIDO

GRIP / GRIP / GRIP OBERFLÄCHE / GRIP / ANTIDESLIZANTE

reden

Gres fine porcellanato / Fine porcelain stoneware / Feinsteinzeug / Grès cérame fin / Gres fino porcelánico **UNI EN 14411 G Bla**



BISCUIT 80x80_32"x32" nat



IVORY 80x80_32"x32" nat

reden

Gres fine porcellanato / Fine porcelain stoneware / Feinsteinzeug / Grès cérame fin / Gres fino porcelánico **UNI EN 14411 G Bla**



BISCUIT Decoro in linea 60x60_24"x24" nat



DARK GREY Esagone 30x37_ 12"x14^{9/16"} nat

reden

Gres fine porcellanato / Fine porcelain stoneware / Feinsteinzeug / Grès cérame fin / Gres fino porcelánico **UNI EN 14411 G Bla**

Ivory

Biscuit

Grey

NATURALE
NATURAL / NATUR / NATUREL / NATURAL

LAPPATO
SEMI-POLISHED / LEICHT POLIERT / SEMI-POLI / PULIDO

GRIP
GRIP / GRIP OBERFLÄCHE / GRIP / ANTIDESLIZANTE



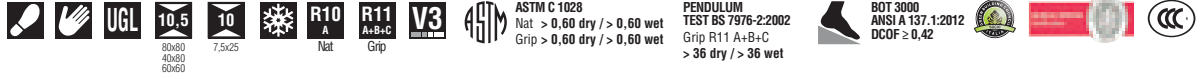

Dark Grey

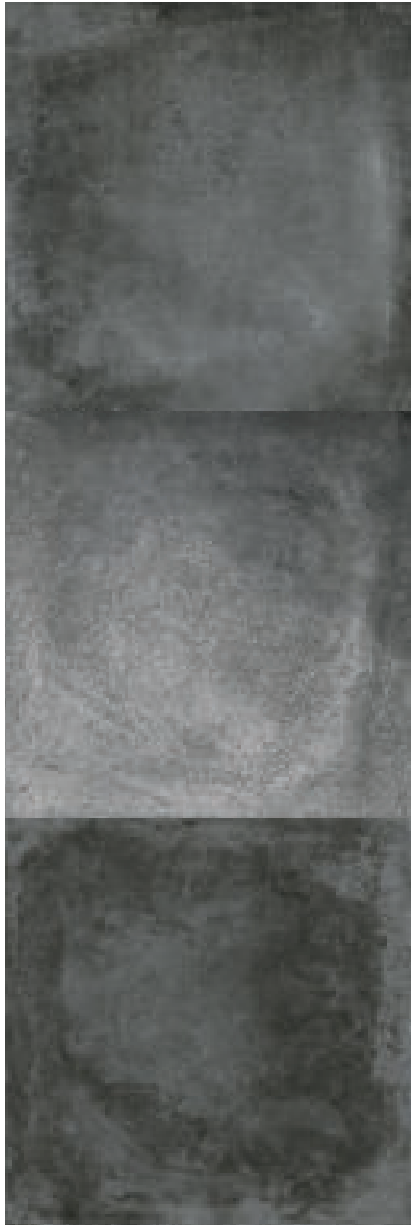

NATURALE
NATURAL / NATUR / NATUREL / NATURAL

LAPPATO
SEMI-POLISHED / LEICHT POLIERT / SEMI-POLI / PULIDO

GRIP
GRIP / GRIP OBERFLÄCHE / GRIP / ANTIDESLIZANTE

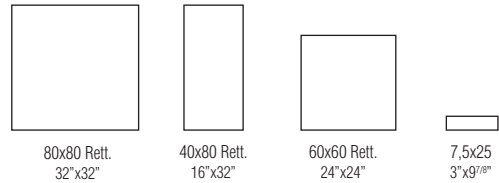

NATURALE

NATURAL / NATUR / NATUREL / NATURAL

Ivory	0052501	0052503	0052509	0052507
Biscuit	0052526	0052528	0052534	0052513
Grey	0052551	0052553	0052559	0052557
Dark Grey	0052576	0052578	0052584	0052582

LAPPATO

SEMI-POLISHED / LEICHT POLIERT / SEMI-POLI / PULIDO

Ivory	0052502	-	0052510
Biscuit	0052527	-	0052535
Grey	0052552	-	0052560
Dark Grey	0052577	-	0052585

GRIP

GRIP / GRIP OBERFLÄCHE / GRIP / ANTIDESLIZANTE

Ivory	0052524	-	0052521
Biscuit	0052549	-	0052546
Grey	0052574	-	0052571
Dark Grey	0052599	-	0052596

reden

Gres fine porcellanato / Fine porcelain stoneware / Feinsteinzeug / Grès cérame fin / Gres fino porcelánico **UNI EN 14411 G Bla**

Ivory

Biscuit



Decoro in linea nat.-rett. 60x60 - 24"x24" / 6 motivi-items

0052518

Decoro in linea nat.-rett. 60x60 - 24"x24" / 6 motivi-items

0052543

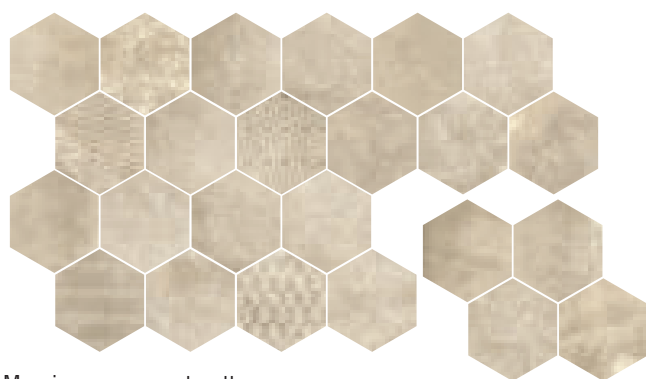

Mosaico esagone nat.-rett.

30x37 - 12"x14^{9/16}" / 6 motivi-items

0052512

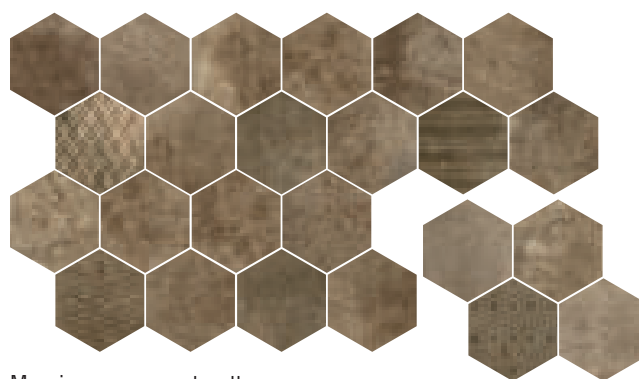

Mosaico esagone nat.-rett.

30x37 - 12"x14^{9/16}" / 6 motivi-items

0052537

Grey

Dark Grey

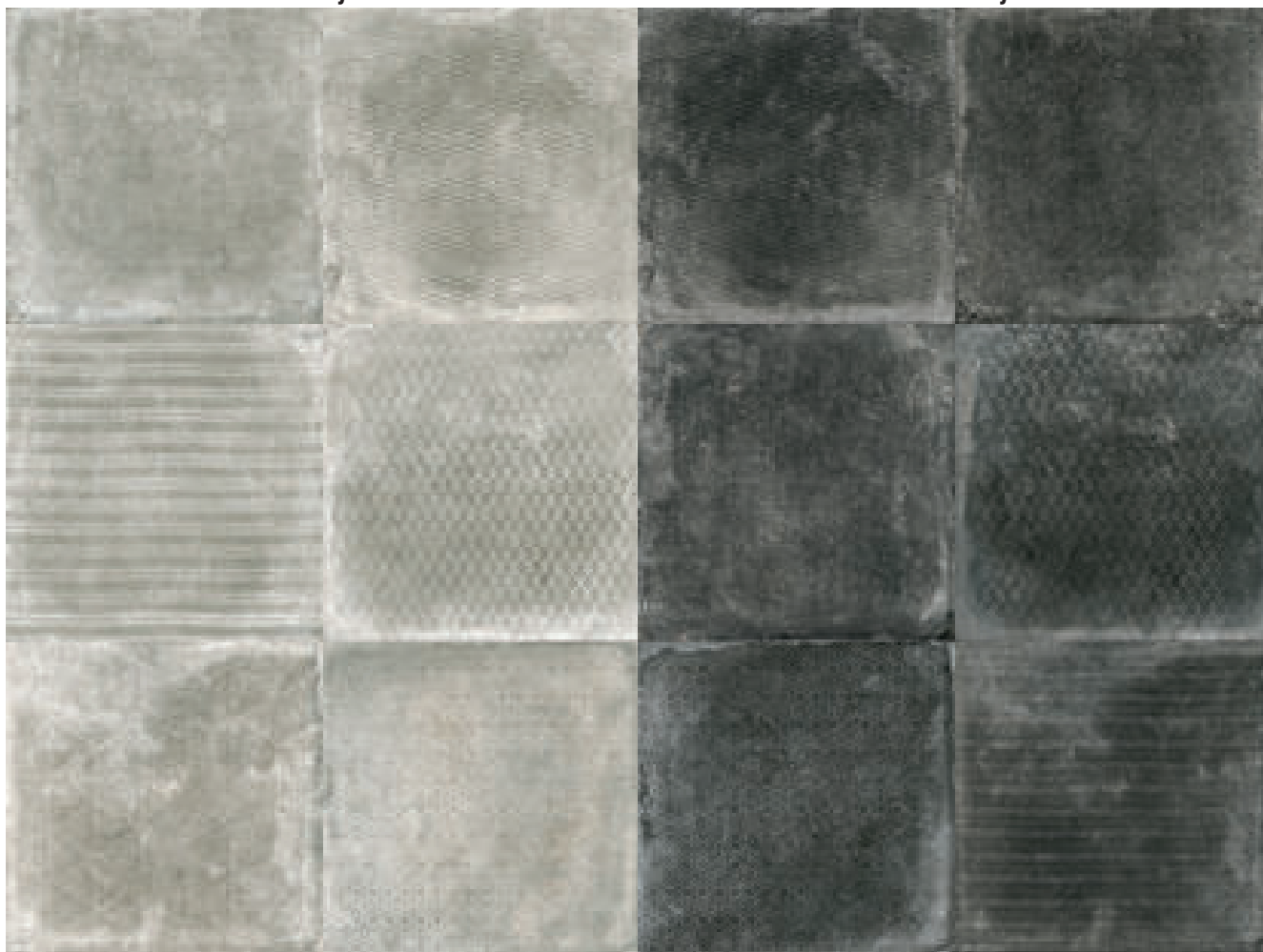

Decoro in linea nat.-rett. 60x60 - 24"x24" / 6 motivi-items

0052568

Decoro in linea nat.-rett. 60x60 - 24"x24" / 6 motivi-items

0052593

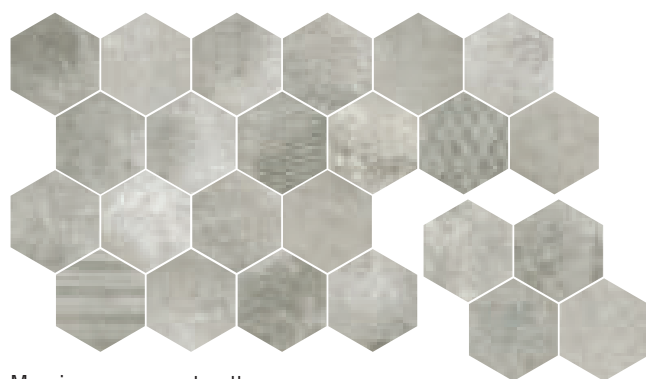

Mosaico esagone nat.-rett.

30x37 - 12"x14^{9/16"} / 6 motivi-items

0052562

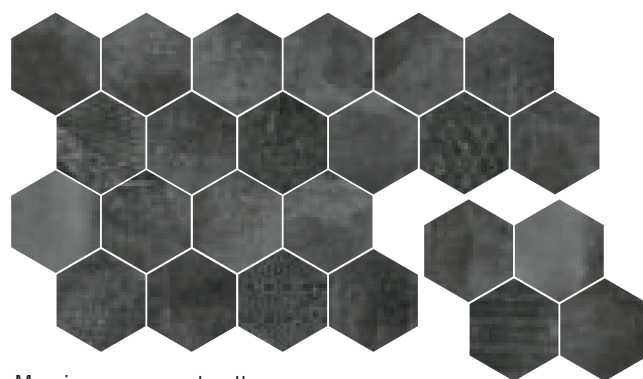

Mosaico esagone nat.-rett.

30x37 - 12"x14^{9/16"} / 6 motivi-items

0052587

reden

Gres fine porcellanato / Fine porcelain stoneware / Feinsteinzeug / Grès cérame fin / Gres fino porcelánico **UNI EN 14411 G Bia**

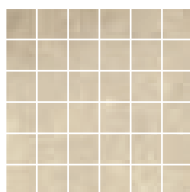

IVORY
0052511 Mosaico nat.-rett.
30x30 - 12"x12" / 5x5 - 2"x2"
4 pcs x box

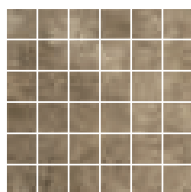

BISCUIT
0052536 Mosaico nat.-rett.
30x30 - 12"x12" / 5x5 - 2"x2"
4 pcs x box

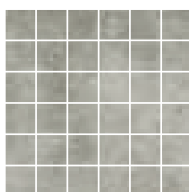

GREY
0052561 Mosaico nat.-rett.
30x30 - 12"x12" / 5x5 - 2"x2"
4 pcs x box

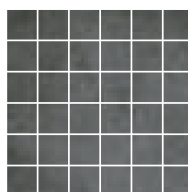

DARK GREY
0052586 Mosaico nat.-rett.
30x30 - 12"x12" / 5x5 - 2"x2"
4 pcs x box



BATTISCOPA

nat. rett.
8x80
3¹⁶"x32"



BATTISCOPA

nat. rett.
7x60
2³/₁₆"x24"



ELEMENTO L

grip rett.
15x60x4
6"x24"x1²/₃₂"



GRAD. LIN. DOPPIA VELA

nat. rett.
33x60x4x2
13"x24"x1²/₃₂"x1³/₁₆"



ANG. GRAD. LIN. DOPPIA VELA SX

nat. rett.
33x60x4x2
13"x24"x1²/₃₂"x1³/₁₆"



ANG. GRAD. LIN. DOPPIA VELA DX

nat. rett.
33x60x4x2
13"x24"x1²/₃₂"x1³/₁₆"

	0052505	0052506	0052522	0052514	0052516	0052515
Ivory						
Biscuit	0052530	0052531	0052547	0052539	0052541	0052540
Grey	0052555	0052556	0052572	0052564	0052566	0052565
Dark Grey	0052580	0052581	0052597	0052589	0052591	0052590

Imballi / Packing / Verpackungen / Emballages / Embalajes

Formato	Pezzi/Sc.	Mq/Sc	Sc/Pal	Mq/Pal	Kg/Sc	Kg/Pal
Size	Pcs/Box	Sq.M/Box	Box/Pal	Sq.M/Pal	Kg/Box	Kg/Pal
Grösse	Pcs/Ctn	Mq/Ctn	Ctn/Pal	Mq/Pal	Kg/Ctn	Kg/Pal
Format	Stck/Kart	Qm/Kart	Kart/Pal	Qm/Pal	Kg/Kart	Kg/Pal
Tamaño	Piezas/Caja	Mq/Caja	Caja/Pal	Mq/Pal	Kg/Caja	Kg/Pal
80x80 nat rett / lapp rett / grip rett	2	1,28	40	51,20	30	1200
40x80 nat rett	3	0,96	56	53,76	23,7	1327,2
60x60 nat rett / lapp rett / grip rett	3	1,08	32	34,56	25,5	816
7,5x25 nat	44	0,825	66	54,45	18	1188
30x37 mosaico esagone	4	0,44	48	21,12	12	576
30x30 mosaico 5x5	4	0,36	60	21,60	8,5	510
8x80 battiscopa	10	0,64	50	32	15	750
7x60 battiscopa	14	0,59	63	37,17	15	945
15x60x4 elemento a "L"	4	0,36	30	10,80	12	360
33x60x4x2 gradone lineare doppia vela	4	0,79	-	-	22	-
33x60x4x2 gradone angolare doppia vela	2	0,4	-	-	11	-



UGL

10.5

80x80
40x80
60x60

10

7.5x25



R10

A

Nat

R11

A+B+C

Grip

V3

1000000000



ASTM C 1028

Nat > 0,60 dry / > 0,60 wet

Grip > 0,60 dry / > 0,60 wet

PENDULUM

TEST BS 7976-2:2002

Grip R11 A+B+C

> 36 dry / > 36 wet



BOT 3000

ANSI A 137.1:2012

DCOF ≥ 0,42



CCC



DARK GREY 80x80_32"x32" nat

tinte unite / graniti

Gres fine porcellanato / Fine porcelain stoneware / Feinsteinzeug / Grès cérame fin / Gres fino porcelánico **UNI EN 14411 G Bia**

SUPERFICI-SPESSORI / SURFACES-THICKNESS / OBERFLÄCHE-STÄRCKE / SURFACES-ÉPAISSEUR / SUPERFICIES-ESPESOR

NATURALE R9



NATURALE: Superficie liscia priva di qualsiasi trattamento superficiale.

NATURAL: Smooth, untreated surface.

BRUT: Surface lisse sans aucun traitement de surface

NATUR: Glatte Oberfläche ohne zusätzliche Oberflächenbehandlungen.

MATE: Superficie lisa carente de cualquier tratamiento superficial.

FORMATO SIZE DIMENSIONS MABEN FORMATO	SPESSORE THICKNESS ÉPAISSEUR STÄRCKE ESPESOR
---	--

30x30	8 mm
20x20	8 mm

SLATE R11 A+B



SLATE: Superficie simile a quello delle pietre naturali lavorate a spacco. Buone caratteristiche antiscivolo.

SLATE: Surface similar to that of natural cleft stone. Exceptional non-slip characteristics.

SLATE: Surface semblable à celle des pierres naturelles fendues. Bonnes caractéristiques d'antiglisance.

SLATE: Oberfläche ähnlich der Oberflächenstruktur von gebrochenen Natursteinen. Hohe Rutschfestigkeit.

SLATE: Superficie parecida a la de las piedras naturales cortadas de manera irregular. Buenas características antideslizantes.

FORMATO SIZE DIMENSIONS MABEN FORMATO	SPESSORE THICKNESS ÉPAISSEUR STÄRCKE ESPESOR
---	--

30x30	8 mm
-------	------



graniti



Gres fine porcellanato / Fine porcelain stoneware / Feinsteinzeug / Grès cérame fin / Gres fino porcelánico **UNI EN 14411 G Bia**

NATURALE / NATURAL / NATUR / NATUREL / NATURAL

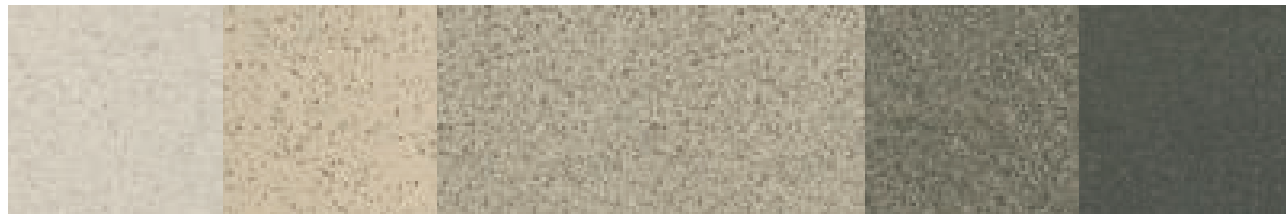

Punto	Bianco Alpi	Grigio	Grigio Granite	Grigio Scuro	Nero Macchiato
30x30 - 12"x12"	30x30 - 12"x12"	30x30 - 12"x12"	30x30 - 12"x12"	30x30 - 12"x12"	30x30 - 12"x12"
8 mm	8 mm	8 mm	8 mm	8 mm	8 mm
20x20 - 8"x8"	20x20 - 8"x8"	20x20 - 8"x8"	20x20 - 8"x8"	20x20 - 8"x8"	20x20 - 8"x8"
8 mm	8 mm	8 mm	8 mm	8 mm	8 mm

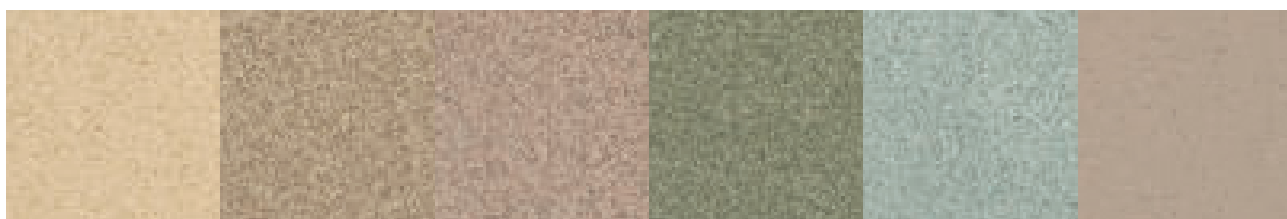

Beige	Mandorla con Spezia	Rosa Antico	Verde Alghero	Labradorite	Marrone Cannella
30x30 - 12"x12"	30x30 - 12"x12"	30x30 - 12"x12"	30x30 - 12"x12"	30x30 - 12"x12"	30x30 - 12"x12"
8 mm	8 mm	8 mm	8 mm	8 mm	8 mm
20x20 - 8"x8"	20x20 - 8"x8"	20x20 - 8"x8"	20x20 - 8"x8"	20x20 - 8"x8"	20x20 - 8"x8"
8 mm	8 mm	8 mm	8 mm	8 mm	8 mm

GAMMA COLORI	30x30 8 mm	State 30x30 8mm	20x20 8 mm	Gradino inciso 30x30 pcs/box 15	Battiscopa 10x30 pcs/box 30
RANGE OF COLORS					
GAMME DE COULEURS					
FARBEN PALETTE					
GAMA DE COLORES					
PUNTO	0089612	-	0086612	0089012	0090812
BIANCO ALPI	0014305	0014355	0014005	0014505	0090805
GRIGIO	0089641	0089891	0086641	0089041	0090841
GRIGIO GRANITE	0089740	0089890	0086740	0089040	0090840
GRIGIO SCURO	0089642	0089892	0086642	0089042	0090842
NERO MACCHIATO	0089604	-	0086604	-	0090804
BEIGE	0089611	0089811	0086611	0089001	0090801
MANDORLA CON SPEZIA	0089655	-	0086655	-	0090855
ROSA ANTICO	0089756	-	0086756	0089056	0090856
VERDE ALGHERO	0014307	-	0014007	0014507	0090807
LABRADORITE	0089649	-	0086649	0089049	0090849
MARRONE CANNELLA	0089616	-	0086616	-	0090816

GAMMA COLORI	Battiscopa con B.C. 10x20 pcs/box 25	Term. SX 10x20 pcs/box 25	Term. DX 10x20 pcs/box 25	Sguscia B.C. 15x20 pcs/box 24	Angolo Int. B.C. H: 15 cm pcs/box 4	Angolo Est. B.C. H: 15 cm pcs/box 4
RANGE OF COLORS						
GAMME DE COULEURS						
FARBEN PALETTE						
GAMA DE COLORES						
PUNTO	0080612	0083402	0080402	0082012	0082412	0082312
BIANCO ALPI	0014605	0083405	0080405	0082005	0082405	0082305
GRIGIO	0080641	0083441	0080441	0082041	0082441	0082341
GRIGIO GRANITE	0080740	0083440	0080440	0082040	0082440	0082340
GRIGIO SCURO	0080642	0083442	0080442	0082042	0082442	0082342
NERO MACCHIATO	0080604	0083404	0080404	0082004	0082404	0082304
BEIGE	0080601	0083401	0080401	0082001	0082401	0082301
MANDORLA CON SPEZIA	0080655	0083455	0080455	0082055	0082455	0082355
ROSA ANTICO	0080756	0083456	0080456	0082056	0082456	0082356
VERDE ALGHERO	0014607	0083407	0080407	0082007	0082407	0082307
LABRADORITE	0080649	0083449	0080449	0082049	0082449	0082349
MARRONE CANNELLA	0080616	0083416	0080416	0082016	0082416	0082316

tinte unite



Gres fine porcellanato / Fine porcelain stoneware / Feinsteinzeug / Grès cérame fin / Gres fino porcelánico **UNI EN 14411 G Bia**

NATURALE / NATURAL / NATUR / NATUREL / NATURAL



Bianco Ghiaccio
30x30 - 12"x12" 8 mm
20x20 - 8"x8" 8 mm

LEVIGATO / POLISHED / POLIERT / POLI / PULIMENTADO



Bianco Ghiaccio Levigato
30x30 - 12"x12" 8 mm

PEZZI SPECIALI / TRIMS / FORMSTÜCKE / PIÈCES SPÉCIALES / PIEZAS ESPECIALES



ANGOLO INTERNO
 INTERNAL ANGLE
 ANGLE INTERNAL
 INNENECKE
 EXQUINA INTERIOR
 H:11 - 4^{1/2}"
 H:15 - 6"

SGUSCIA B.C.
 COVE BASE
 PLINTHE A GORGE
 HÖHLKEHLENSOCKELLEISTE
 ZÓCALO ESCOCIA
 11x30 - 4"x12"
 15x20 - 6"x8"

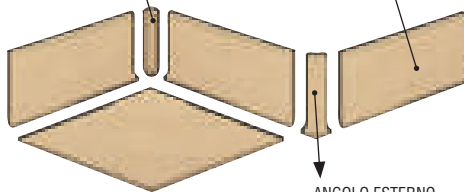

ANGOLO ESTERNO
 EXTERNAL ANGLE
 ANGLE EXTERIEUR
 AUSSENECKE
 EXQUINA EXTERIOR
 H:11 - 4^{1/2}"
 H:15 - 6"



BATTISCOPIA B.C.
 SKIRTING B.C.
 PLINTHE B.C.
 SOCKELLEISTE B.C.
 RODAPIES B.C.
 10x20 - 4"x8"



TERMINALE (SX)
 EDGING PIECE (SX)
 ENDABDECKLEISTE (SX)
 ÉLÉMENT FINAL (SX)
 TERMINAL (SX)
 10x20 - 4"x8"



TERMINALE (DX)
 EDGING PIECE (DX)
 ENDABDECKLEISTE (DX)
 ÉLÉMENT FINAL (DX)
 TERMINAL (DX)
 10x20 - 4"x8"

	30x30 8 mm	Levigato 30x30 8 mm	20x20 8 mm	Gradino inciso 30x30 pcs/box 15

BIANCO GHIACCIO 0089328 0089128 0086328 0087928

	Battiscopa 10x30 pcs/box 30	Battiscopa con B.C. 10x20 pcs/box 25	Term. SX 10x20 pcs/box 25	Term. DX 10x20 pcs/box 25	Sguscia B.C. 15x20 pcs/box 24	Angolo Int. B.C. H: 15 cm pcs/box 4	Angolo Est. B.C. H: 15 cm pcs/box 4

BIANCO GHIACCIO 0090828 0080328 0083428 0080428 0082028 0082428 0082328

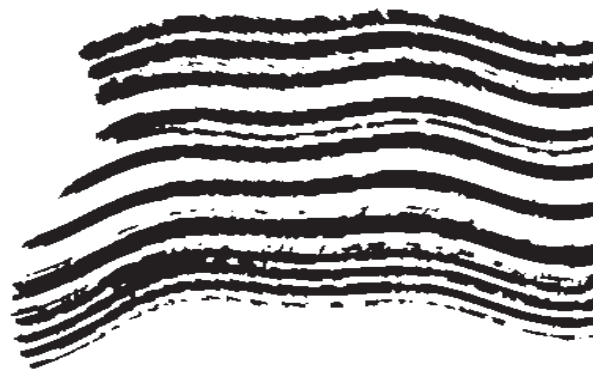

POOL COLLECTION

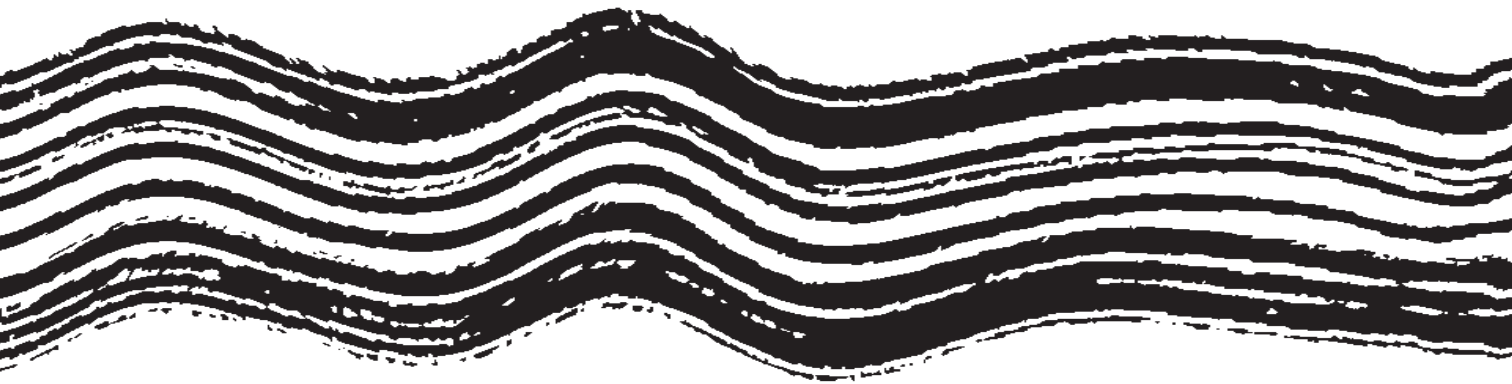

H₂O LIFE PROJECT

Sistemi bordi piscina Pool edges / Beckenrandfliesen / Bordures de piscine / Bordes de piscina



Puntozero Latte Grip Rett. 20x120
Wav.E 30x60
Griglia Steel-Gres 20x60 + Angolo Steel-Gres 20x20



Bordo Round.E Neostone Avorio Grip 30x50
Griglia Steel-Gres Neostone Avorio Grip 20x50
Neostone Grigio Grip 50x100

H₂O LIFE PROJECT

Sistemi bordi piscina Pool edges / Beckenrandfliesen / Bordures de piscine / Bordes de piscina

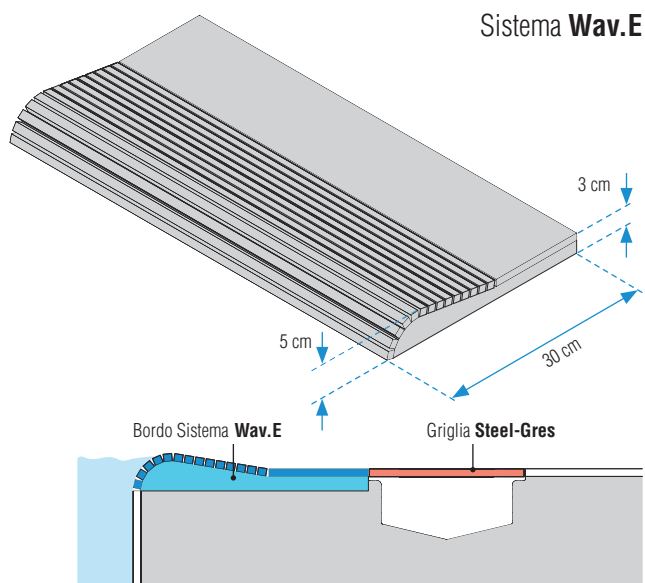
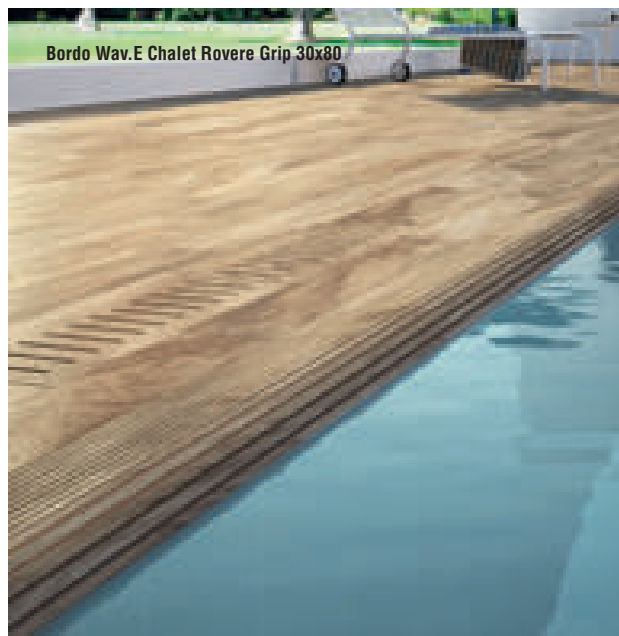

Bordo a listelli pre-sagomato su supporto di cemento alleggerito
 Non-flexible strip edge tile on support made of lightened concrete / Randstein bestehend aus geschnittenen Streifen auf entlastet Zement / Bord à lattes préformé sur support en béton maigre / Borde con listones no flexible pre-soporte en cemento reducido

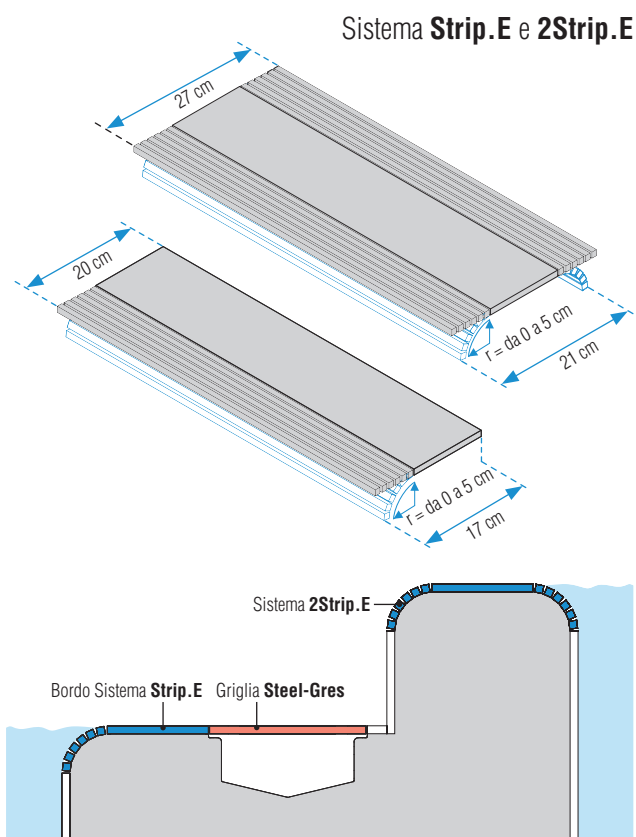
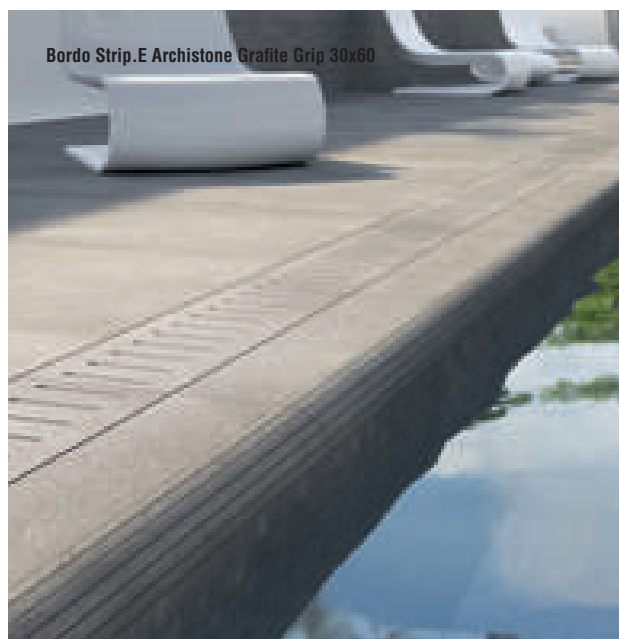

Bordo e doppio bordo a listelli sagomabili su rete
 Flexible and double flexible strip edge tile on net / Netzverklebte Streifen für Randstein und Doppelrandstein / Bord et double bord à lattes flexibles sur filet / Borde y doble borde con listones flexible en la red

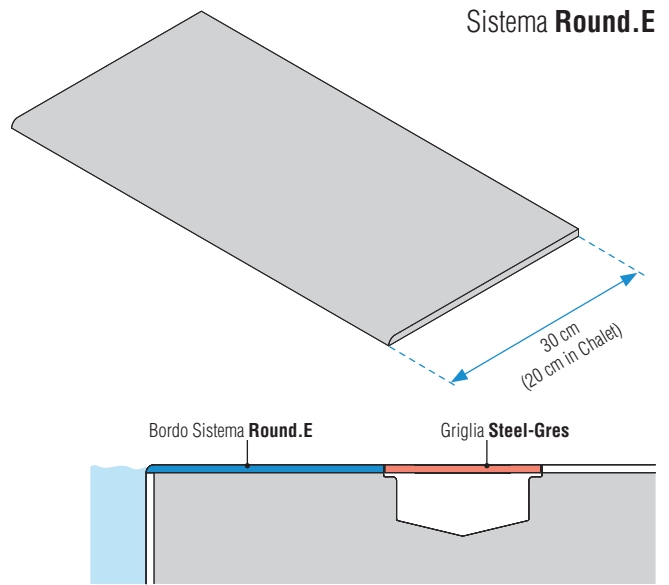

Bordo a Becco di Civetta
Round Edge Tile / Abgerundeter Randstein / Bord arrondi / Borde redondeado

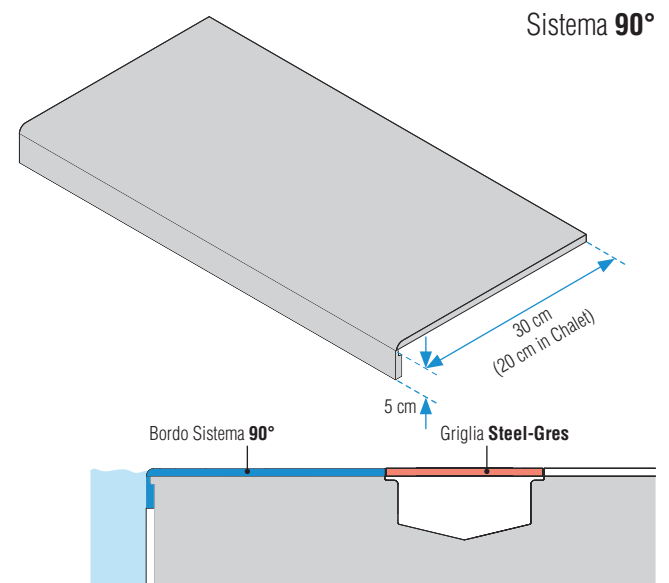
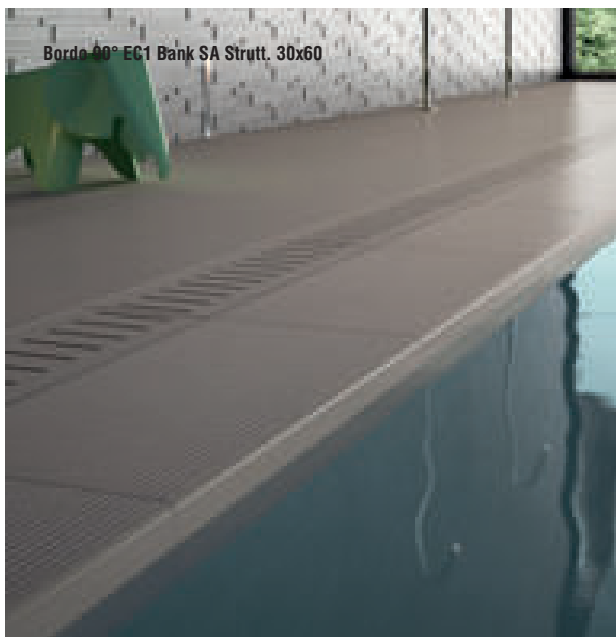

Bordo a 90° con Becco Civetta
90° Straight Edge Tile / 90° Winkel Randstein / Bord 90° (avec retombée) / Borde a 90°

H₂O LIFE PROJECT

Griglie e pezzi speciali / Grid and trims / Raster und Formteile / Grille et pièces spéciales / Rejilla y piezas especiales

Griglia Steel-Gres

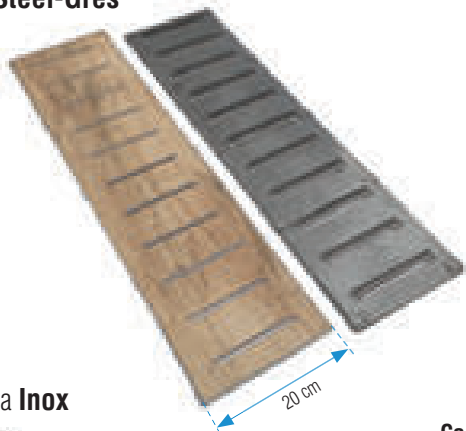

Griglia lineare e angolo griglia con lastra in ceramica e custodia in acciaio AISI 304 lucidato resistente agli acidi

Straight grid and corner grid tile with ceramic slab and steel case AISI 304 smoothed and acid resilient
Lineares Raster und Eckstück aus Keramik mit Halterung in Edelstahl AISI 304 säurebeständig
Grille linéaire et angle grille avec dalle en grès et support en acier poli AISI 304 résistant aux acides
Rejilla lineal y angular rejilla con plato de cerámica y cubierta en acero pulido caso AISI 304 resistente al ácido

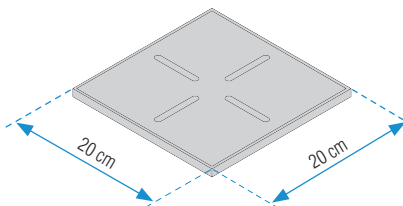

Canaletta Inox

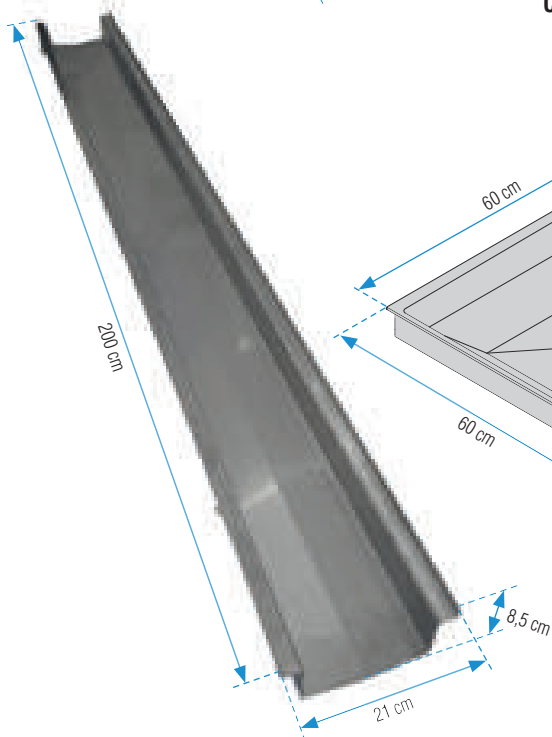

Canaletta e flange di giunzioni in acciaio AISI 304 lucidato resistente agli acidi

Stainless steel AISI 304 gutter and flanges connection smoothed and acid resilient
Rinne mit Befestigung in Edelstahl AISI 304 säurebeständig
Caneau et bride de raccord en acier poli AISI 304 résistant aux acides
Conducto bridas y juntas de acero AISI 304 pulido resistente a los ácidos

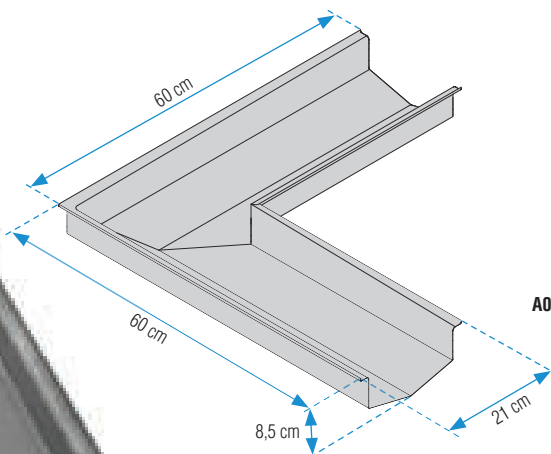

A003630 Canaletta Inox con foro e con flange di testa

Stainless steel gutter with hole and end flanges
Edelstahlrinne mit Loch und Befestigungen
Caneau inox avec trou et brides de tête
Canal de acero con agujero y la brida de cabeza

A003631 Canaletta Inox senza foro e con flange di testa

Stainless steel gutter without hole and end flanges
Edelstahlrinne ohne Loch und ohne Befestigung
Caneau inox sans trou, avec brides de tête
Canal de acero sin orificio y la brida de cabeza

A003632 Canaletta Inox senza foro con una flangia di testa

Stainless steel gutter without hole and with one end flange
Edelstahlrinne mit Loch und Befestigung
Caneau inox sans trou, avec un bride de tête
Canal de acero sin agujero con una cabeza de brida

A003633 Angolo canaletta Inox

Stainless steel gutter corner
Edelstahlrinnecke
Angle canneau inox
Ángulo de acero del canal

A003634 Flangia di giunzione in Inox

Stainless steel connection flange
Befestigung in Edelstahl
Bride de raccord inox
Juntas de bridas de acero

A003641 Chiusura per canale in Inox

Closing stainless channel
Schließen rostfreien Kanal
Fermeture de caniveau en acier inoxydable
Cierre de canaleta en acero inoxidable

Sistema di raccolta acqua

Water collection system / Wassersammelsystem / Système de recolté eau / Sistema de recogida agua

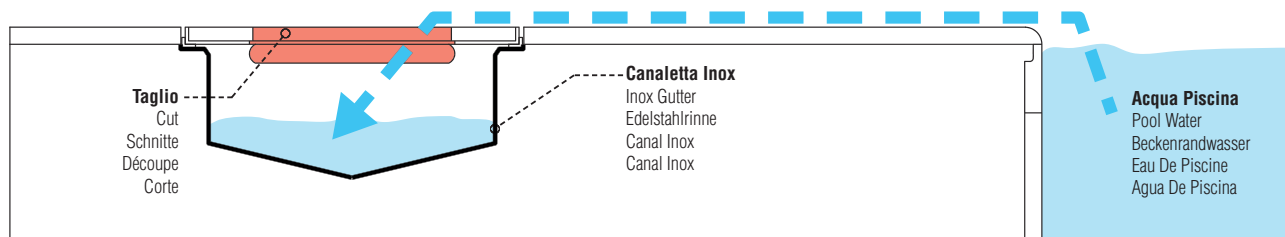

L'acqua entra nella Canaletta Inox attraverso i tagli della Griglia Steel-Gres

Water enters the Inox Gutter through the cuts of the Steel-Gres grid / Das Wasser fließt in die Edelstahlrinne durch das Raster im Steel-Gres hinein / L'eau pénètre dans le Caniveau Inox à travers les découpes de la grille Steel-Gres / El agua entra en el Canal Inox por los cortes de la rejilla Steel-Gres

Griglia **Double-Gres**



Griglia lineare e angolo griglia con due lastre in ceramica incollate sovrapposte

Straight grid and corner grid tile with two ceramic slabs pasted each-other
Lineares Raster und Eckstück aus Keramik mit Keramikstegen
Grille linéaire et angle grille avec deux dalles en grès collées superposées
Rejilla lineal y angular rejilla con dos placas de cerámica unidas superpuestas

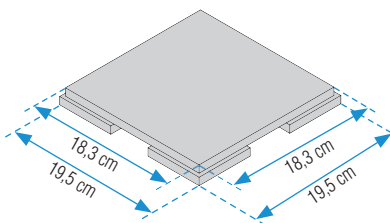

Canaletta **Concrete**

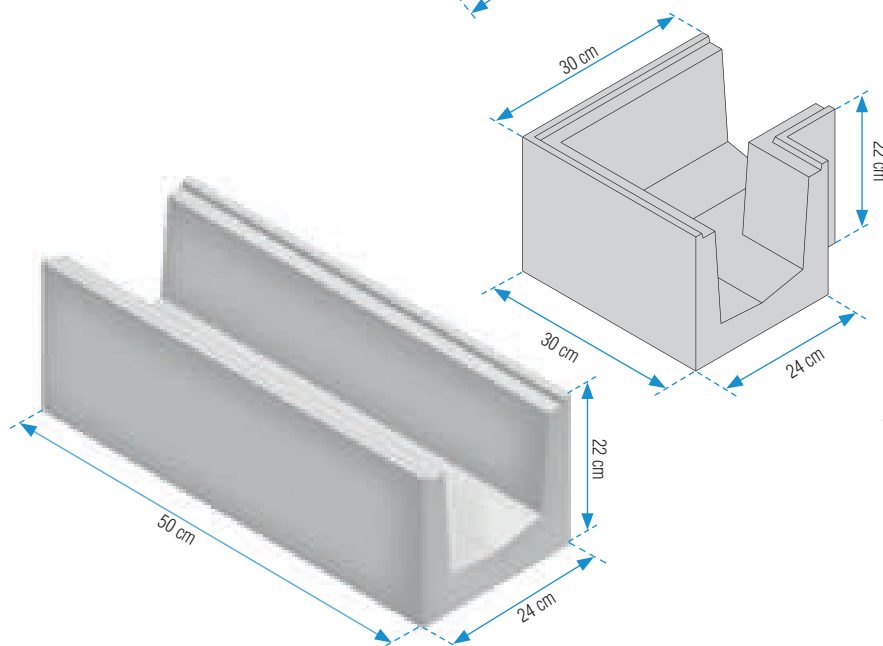

Canala di sfioro in pietra ricostruita

Spillway gutter made of reconstructed stone
Gussbetonrinne
Goulotte de débordement en pierre reconstituée
Canal de desbordamiento en piedra reconstruida

A004033 Canala di sfioro in pietra ricostruita

Spillway gutter made of reconstructed stone
Gussbetonrinne
Goulotte de débordement en pierre reconstituée
Canal de desbordamiento en piedra reconstruida

A004034 Angolo canala di sfioro in pietra ricostruita

Spillway gutter corner made of reconstructed stone
Gussbetonrinnenecke
Angle goulotte de débordement en pierre reconstituée
Angulo de canal de desbordamiento en piedra reconstruida

A004035 Canala di sfioro in pietra ricostruita con foro

Spillway gutter made of reconstructed stone with hole
Gussbetonrinne mit Loch
Goulotte de débordement en pierre reconstituée avec trou
Canal de desbordamiento en pietra ricostruita con agujero

Sistema di raccolta acqua

Water collection system / Wassersammelsystem / Système de recolté eau / Sistema de recogida agua

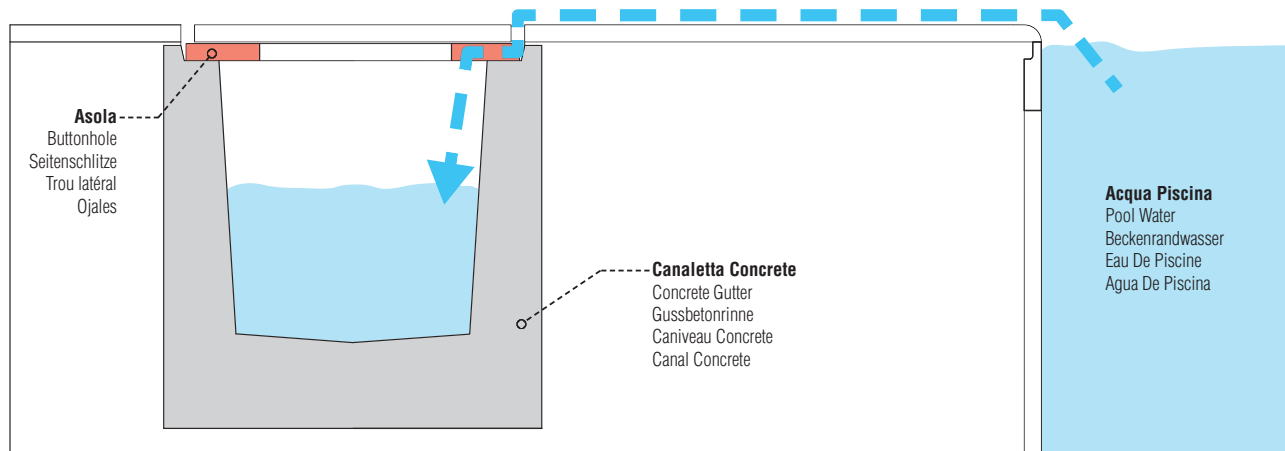

L'acqua entra nella Canaletta Concrete attraverso le asole della Griglia Double-Gres

Water enters the Concrete gutter through the buttonholes of the Double-Gres grid / Das Wasser fließt in die Gussbetonrinne durch die Seitenschlitze des Double-Gres Raster / L'eau pénètre dans le Caniveau Concrete à travers les trou latéral de la grille Double-Gres / El agua entra en el Canal Concrete por los ojales de la rejilla Double-Gres

H₂O LIFE PROJECT

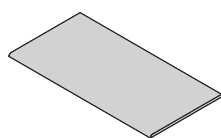

Round.E

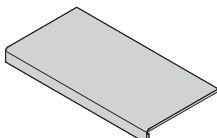

90°

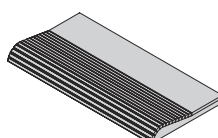

Wav.E

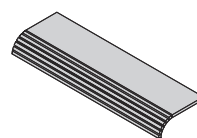

Strip.E

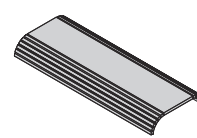

2Strip.E

ARCHISTONE GRIP / GRIP / GRIP OBERFLÄCHE / GRIP / ANTIDESLIZANTE

	30x60 - 12"x24"	30x60 - 12"x24"	30x60 - 12"x24"	20x60 - 8"x24"	27x60 - 10 ^{9/16} "x24"
Grafite	0003552	0003568	0003627	0003595	0003611
Limestone Bianco	0003553	0003569	0003628	0003596	0003612
Limestone Crema	0003554	0003570	0003629	0003597	0003613

CHALET GRIP / GRIP / GRIP OBERFLÄCHE / GRIP / ANTIDESLIZANTE

	20x80 - 8"x32"	30x80 - 12"x32"	30x80 - 12"x32"	17x80 - 6 ^{11/16} "x32"	24x80 - 9 ^{7/16} "x32"
Rovere	0003550	0003562	0003621	0003589	0003605
Ciliegio	0003551	0003563	0003622	0003590	0003606
Bianco	0003549	0003561	0003620	0003588	0003604
Nero	0003500	0003564	0003623	0003591	0003607

EC1 STRUTTURATO / TEXTURED / STRUKTURIERTE / STRUCTURÉE / ESTRUCTURADO

	30x60 - 12"x24"	30x60 - 12"x24"	30x60 - 12"x24"	20x60 - 8"x24"	27x60 - 10 ^{9/16} "x24"
Farringdon Bl	0003543	0003555	0003614	0003571	0003598
City AN	0003547	0003559	0003618	0003512	0003602
Barbican NE	0003548	0003560	0003619	0003513	0003603
Bank SA	0003544	0003556	0003615	0003509	0003599
Holborn TA	0003545	0003557	0003616	0003510	0003600
Docks FA	0003546	0003558	0003617	0003511	0003601

NEOSTONE GRIP / GRIP / GRIP OBERFLÄCHE / GRIP / ANTIDESLIZANTE

	30x50 - 12"x20"	33x50 - 13"x20"	30x50 - 12"x20"	20x50 - 8"x20"	27x50 - 10 ^{9/16} "x20"
Avorio	0003501	0003565	0003624	0003592	0003608
Grigio	0003502	0003566	0003625	0003593	0003609
Antracite	0003503	0003567	0003626	0003594	0003610

PUNTOZERO GRIP / GRIP / GRIP OBERFLÄCHE / GRIP / ANTIDESLIZANTE

	30x60 - 12"x24"	30x60 - 12"x24"	30x60 - 12"x24"	20x60 - 8"x24"	27x60 - 10 ^{9/16} "x24"
Riso	0003780	0003786	0003804	0003792	0003798
Corde	0003781	0003787	0003805	0003793	0003799
Biscotto	0003782	0003788	0003806	0003794	0003800
Latte	0003783	0003789	0003807	0003795	0003801
Nuvola	0003784	0003790	0003808	0003796	0003802
Cenere	0003785	0003791	0003809	0003797	0003803

Pezzi/Sc.
Pcs/Box / Pcs/Ctn
Stck/Kart / Piezas/Caja

Mq/Sc
Sq.M/Box / Mq/Ctn
Qm/Kart / Mq/Caja

Kg/Sc
Kg/Box / Kg/Ctn
Kg/Kart / Kg/Caja

Pezzi/Sc.
Pcs/Box / Pcs/Ctn
Stck/Kart / Piezas/Caja

Mq/Sc
Sq.M/Box / Mq/Ctn
Qm/Kart / Mq/Caja

Kg/Sc
Kg/Box / Kg/Ctn
Kg/Kart / Kg/Caja

ARCHISTONE

Round.E	6	1,08	25,5
90°	4	0,72	17
Wav.E	1	0,18	14,5
Strip.E	4	0,48	16,5
2Strip.E	4	0,64	18

CHALET

Round.E	6	0,96	15,6
90°	2	0,32	5,2
Wav.E	1	0,24	18,2
Strip.E	4	0,64	9,6
2Strip.E	4	0,86	12

EC1

Round.E	6	1,08	27
90°	4	0,72	18
Wav.E	1	0,18	14,5
Strip.E	4	0,48	16,5
2Strip.E	4	0,64	18

NEOSTONE

Round.E	6	0,9	22,5
90°	4	0,6	15
Wav.E	1	0,15	11,8
Strip.E	4	0,4	14,6
2Strip.E	4	0,54	16

PUNTOZERO

Round.E	6	1,08	27
90°	4	0,72	18
Wav.E	1	0,18	14,5
Strip.E	4	0,48	16,5
2Strip.E	4	0,64	18

ARCHISTONE / CHALET / EC1 / NEOSTONE / PUNTOZERO

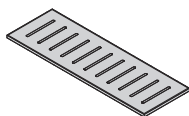

Griglia Steel-Gres



Angolo Steel-Gres

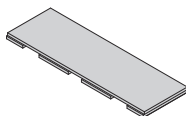

Griglia Double-Gres

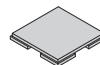

Angolo Double-Gres

ARCHISTONE GRIP / GRIP / GRIP OBERFLÄCHE / GRIP / ANTIDESLIZANTE				
	20x60 - 8"x24"	20x20 - 8"x8"	20x60 - 8"x24"	20x20 - 8"x8"
Grafite	0003648	0003664	0003680	0003696
Limestone Bianco	0003649	0003665	0003681	0003697
Limestone Crema	0003650	0003666	0003682	0003698
CHALET GRIP / GRIP / GRIP OBERFLÄCHE / GRIP / ANTIDESLIZANTE				
	20x80 - 8"x32"	20x20 - 8"x8"	20x80 - 8"x32"	20x20 - 8"x8"
Rovere	0003642	0003658	0003674	0003690
Ciliegio	0003643	0003659	0003675	0003691
Bianco	0003641	0003657	0003673	0003689
Nero	0003644	0003660	0003676	0003692
EC1 STRUTTURATO / TEXTURED / STRUKTURIERTE / STRUCTURÉE / ESTRUCTURADO				
	20x60 - 8"x24"	20x20 - 8"x8"	20x60 - 8"x24"	20x20 - 8"x8"
Farringdon Bl	0003635	0003651	0003667	0003683
City AN	0003639	0003655	0003671	0003687
Barbican NE	0003640	0003656	0003672	0003688
Bank Sa	0003636	0003652	0003668	0003684
Holborn Ta	0003637	0003653	0003669	0003685
Docks Fa	0003638	0003654	0003670	0003686
NEOSTONE GRIP / GRIP / GRIP OBERFLÄCHE / GRIP / ANTIDESLIZANTE				
	20x50 - 8"x20"	20x20 - 8"x8"	20x50 - 8"x20"	20x20 - 8"x8"
Avorio	0003645	0003661	0003677	0003693
Grigio	0003646	0003662	0003678	0003694
Antracite	0003647	0003663	0003679	0003695
PUNTOZERO GRIP / GRIP / GRIP OBERFLÄCHE / GRIP / ANTIDESLIZANTE				
	20x60 - 8"x24"	20x20 - 8"x8"	20x60 - 8"x24"	20x20 - 8"x8"
Riso	0003768	0003774	0003699	0003705
Corda	0003769	0003775	0003700	0003706
Biscotto	0003770	0003776	0003701	0003707
Latte	0003771	0003777	0003702	0003708
Nuvola	0003772	0003778	0003703	0003709
Cenere	0003773	0003779	0003704	0003710

	Pezzi/Sc. Pcs/Box / Pcs/Ctn Stck/Kart / Piezas/Caja	Mq/Sc Sq.M/Box / Mq/Ctn Qm/Kart / Mq/Caja	Kg/Sc Kg/Box / Kg/Ctn Kg/Kart / Kg/Caja		Pezzi/Sc. Pcs/Box / Pcs/Ctn Stck/Kart / Piezas/Caja	Mq/Sc Sq.M/Box / Mq/Ctn Qm/Kart / Mq/Caja	Kg/Sc Kg/Box / Kg/Ctn Kg/Kart / Kg/Caja
ARCHISTONE				NEOSTONE			
Steel-Gres	1	0,12	4,2	Steel-Gres	1	0,1	3,7
Ang. Steel-Gres	1	0,04	1,4	Ang. Steel-Gres	1	0,04	1,4
Double-Gres	1	0,12	6,8	Double-Gres	1	0,1	6,1
Ang. Double-Gres	1	0,04	2,2	Ang. Double-Gres	1	0,04	2,2
CHALET				PUNTOZERO			
Steel-Gres	1	0,16	5,2	Steel-Gres	1	0,12	4,4
Ang. Steel-Gres	1	0,04	1,4	Ang. Steel-Gres	1	0,04	1,4
Double-Gres	1	0,16	8,2	Double-Gres	1	0,12	7,2
Ang. Double-Gres	1	0,04	2,2	Ang. Double-Gres	1	0,04	2,2
EC1							
Steel-Gres	1	0,12	4,4				
Ang. Steel-Gres	1	0,04	1,4				
Double-Gres	1	0,12	7,2				
Ang. Double-Gres	1	0,04	2,2				

H₂O SPORT PROJECT

Gres porcellanato smaltato EN 14411 Bla / Glazed porcelain stoneware / Glasiertes Feinsteinzeug / Grès cérame émaillé / Gres porcelánico esmaltado



Sistema Finlandese

Bianco Nat. Matt 12,5x25
Nero Nat. Matt 12,5x25

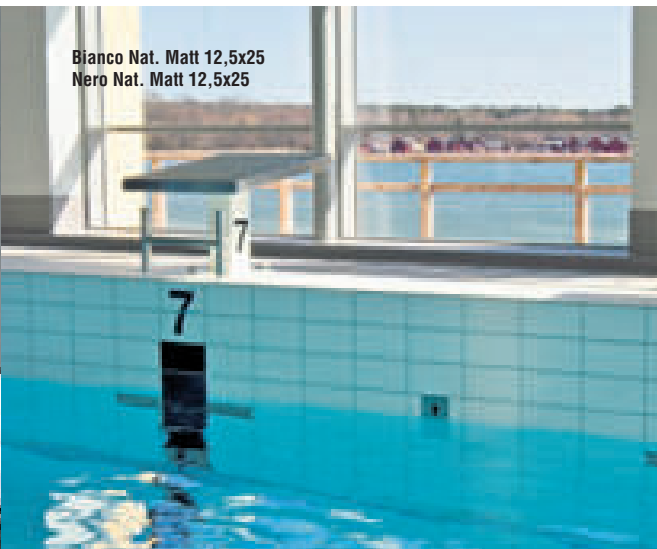

Bianco Nat. Matt 12,5x25
Azzurro Caraibico Nat. Matt 12,5x25
Sguscia esterna Bianco 3x25



Sistema Finlandese



Formati / Sizes / Grösse / Format / Tamaño:



12,5x25
5"x10"

Superfici / Surface / Oberfläche / Surface / Superficie

NATURALI MATT / NATURAL MATT / NATUR MATT / NATUREL MAT / NATURAL MATE

ANTISCIVOLO B MATT / SLIP RESISTANT / TRITTSICHER OBERFLÄCHE
ANTIDÉRAPANTE / ANTIDESLIZANTE

ANTISCIVOLO C MATT / SLIP RESISTANT / TRITTSICHER OBERFLÄCHE
ANTIDÉRAPANTE / ANTIDESLIZANTE

BRILLANTI / GLOSS / GLÄNZEND / BRILLANT / BRILLO

H₂O SPORT PROJECT

Gres porcellanato smaltato EN 14411 Bla / Glazed porcelain stoneware / Glasiertes Feinsteinzeug / Grès cérame émaillé / Gres porcelánico esmaltado

COLORI / COLOURS / FARBEN / COULEURS / COLORES



Bianco

Azzurro Ghiaccio

Azzurro Celeste

Azzurro Atlante

Azzurro Caraibico

Azzurro Petrolio

Blu Cobalto



Grigio Perla

Grigio Argento

Grigio Acciaio

Grigio Piombo

Grigio Profondo

Grigio Antracite

Nero

COLORI COLORS COULEURS FARBEN COLORES	B ≥ 18°		C ≥ 24°		BECCO CIVETTA lato corto		BECCO CIVETTA lato lungo		BECCO CIVETTA ang. destro		BECCO CIVETTA ang. sinistro		B.C. B MATT lato corto		B.C. B MATT lato lungo		B.C. B MATT ang. destro		B.C. B MATT ang. sinistro	
	NATURALE MATT 12,5x25 5'x10"	ANTISCIVOLO B MATT 12,5x25 5'x10"	ANTISCIVOLO C MATT 12,5x25 5'x10"	BRILLANTE 12,5x25 5'x10"	BECCO CIVETTA lato corto 12,5x25 5'x10"	BECCO CIVETTA lato lungo 12,5x25 5'x10"	BECCO CIVETTA ang. destro 12,5x25 5'x10"	BECCO CIVETTA ang. sinistro 12,5x25 5'x10"	B.C. B MATT lato corto 12,5x25 5'x10"	B.C. B MATT lato lungo 12,5x25 5'x10"	B.C. B MATT ang. destro 12,5x25 5'x10"	B.C. B MATT ang. sinistro 12,5x25 5'x10"	B.C. B MATT ang. destro 12,5x25 5'x10"	B.C. B MATT ang. sinistro 12,5x25 5'x10"	B.C. B MATT ang. destro 12,5x25 5'x10"	B.C. B MATT ang. sinistro 12,5x25 5'x10"	B.C. B MATT ang. destro 12,5x25 5'x10"	B.C. B MATT ang. sinistro 12,5x25 5'x10"		
BIANCO	0003322	0003333	0003339	003325	0003366	0003398	0003430	0003462	0003373	0003405	0003437	0003469								
AZZ. GHIACCIO	0003313	-	-	-	0003357	0003389	0003421	0003453	-	-	-	-								
AZZ. CELESTE	0003314	-	-	-	0003358	0003390	0003422	0003454	-	-	-	-								
AZZ. ATLANTE	0003315	-	-	-	0003359	0003391	0003423	0003455	-	-	-	-								
AZZ. CARAIBICO	0003316	0003330	0003337	0003326	0003360	0003392	0003424	0003456	0003370	0003402	0003434	0003466								
AZZ. PETROLIO	0003317	-	-	-	0003361	0003393	0003425	0003457	-	-	-	-								
BLU COBALTO	0003323	0003334	0003340	0003328	0003367	0003399	0003431	0003463	0003374	0003406	0003438	0003470								
GRIGIO PERLA	0003300	-	-	-	0003344	0003376	0003408	0003440	-	-	-	-								
GRIGIO ARGENTO	0003301	-	-	-	0003345	0003377	0003409	0003441	-	-	-	-								
GRIGIO ACCIAIO	0003302	-	-	-	0003346	0003378	0003410	0003442	-	-	-	-								
GRIGIO PIOMBO	0003303	-	-	-	0003347	0003379	0003411	0003443	-	-	-	-								
GRIGIO PROFONDO	0003304	-	-	-	0003348	0003380	0003412	0003444	-	-	-	-								
GRIGIO ANTRACITE	0003305	-	-	-	0003349	0003381	0003413	0003445	-	-	-	-								
NERO	0003324	0003335	-	0003327	0003368	0003400	0003432	0003464	0003375	0003407	0003439	0003471								
GELSOMINO	0003306	0003329	0003336	-	0003350	0003382	0003414	0003446	0003369	0003401	0003433	0003465								
SABBIA	0003308	-	-	-	0003352	0003384	0003416	0003448	-	-	-	-								
BEIGE	0003309	-	-	-	0003353	0003385	0003417	0003449	-	-	-	-								
BEIGE KALAHARI	0003311	-	-	-	0003355	0003387	0003419	0003451	-	-	-	-								
BEIGE BAHAMAS	0003310	-	-	-	0003354	0003386	0003418	0003450	-	-	-	-								
MANDARINO	0003307	-	-	-	0003351	0003383	0003415	0003447	-	-	-	-								
COGNAC	0003312	-	-	-	0003356	0003388	0003420	0003452	-	-	-	-								
VERDE MENTA	0003318	-	-	-	0003362	0003394	0003426	0003458	-	-	-	-								
VERDE ACQUA	0003320	0003331	0003338	-	0003364	0003396	0003428	0003460	0003371	0003403	0003435	0003467								
VERDE MARE	0003321	0003332	-	-	0003365	0003397	0003429	0003461	0003372	0003404	0003436	0003468								
VERDE VITTORIANO	0003319	-	-	-	0003363	0003395	0003427	0003459	-	-	-	-								

Imballi / Packing / Verpackungen / Emballages / Embalajes

Formato	Pezzi/Sc.	Mq/Sc	Sc/Pal	Mq/Pal	Kg/Sc	Kg/Pal
Size	Pcs/Box	Sq.M/Box	Box/Pal	Sq.M/Pal	Kg/Box	Kg/Pal
Größe	Pcs/Ctn	Mq/Ctn	Ctn/Pal	Mq/Pal	Kg/Ctn	Kg/Pal
Format	Stck/Kart	Qm/Kart	Kart/Pal	Qm/Pal	Kg/Kart	Kg/Pal
Tamaño	Piezas/Caja	Mq/Caja	Caja/Pal	Mq/Pal	Kg/Caja	Kg/Pal
12,5x25	32	1	81	81	14,80	1224



A Matt > 0,60 dry / < 0,50 wet
B Matt > 0,60 dry / > 0,60 wet

C Matt > 0,60 dry / > 0,60 wet
Brillanti > 0,60 dry / < 0,50 wet

ANSI A 137.1:2012
B Matt
DCOF ≥ 0,42



ANSI A 137.1:2012
C Matt
DCOF ≥ 0,42



Gelsomino

Sabbia

Beige

Beige Kalahari

Beige Bahamas

Mandarino

Cognac



Verde Menta

Verde Acqua

Verde Mare

Verde Vittoriano

COLORI COLORS COULEURS FARBEN COLORES	SGUSCIA INTERNA 5x25 2'x10"		SGUSCIA ESTERNA 5x25 2'x10"		SGUSCIA INTERNA ang. alto 7x3 2'45"x1'15"		SGUSCIA INTERNA ang. basso 5x5 2'x2"		SGUSCIA ESTERNA ang. alto 5x3,7 2'x1'11"		SGUSCIA ESTERNA ang. basso 7x5 2'45"x2"	
	0003472	0003475	0003478	0003484	0003487	0003481						
AZZ. GHIACCIO	-	-	-	-	-	-						
AZZ. CELESTE	-	-	-	-	-	-						
AZZ. ATLANTE	-	-	-	-	-	-						
AZZ. CARAIBICO	0003473	0003476	0003479	0003485	0003488	0003482						
AZZ. PETROLIO	-	-	-	-	-	-						
BLU COBALTO	-	-	-	-	-	-						
GRIGIO PERLA	-	-	-	-	-	-						
GRIGIO ACCIAIO	-	-	-	-	-	-						
GRIGIO ARGENTO	-	-	-	-	-	-						
GRIGIO PIOMBO	-	-	-	-	-	-						
GRIGIO PROFONDO	-	-	-	-	-	-						
GRIGIO ANTRACITE	-	-	-	-	-	-						
NERO	-	-	-	-	-	-						
GELSOMINO	-	-	-	-	-	-						
SABBIA	-	-	-	-	-	-						
BEIGE	-	-	-	-	-	-						
BEIGE KALAHARI	-	-	-	-	-	-						
BEIGE BAHAMAS	-	-	-	-	-	-						
MANDARINO	-	-	-	-	-	-						
COGNAC	-	-	-	-	-	-						
VERDE MENTA	-	-	-	-	-	-						
VERDE ACQUA	-	-	-	-	-	-						
VERDE MARE	-	-	-	-	-	-						
VERDEVITTORIANO	-	-	-	-	-	-						

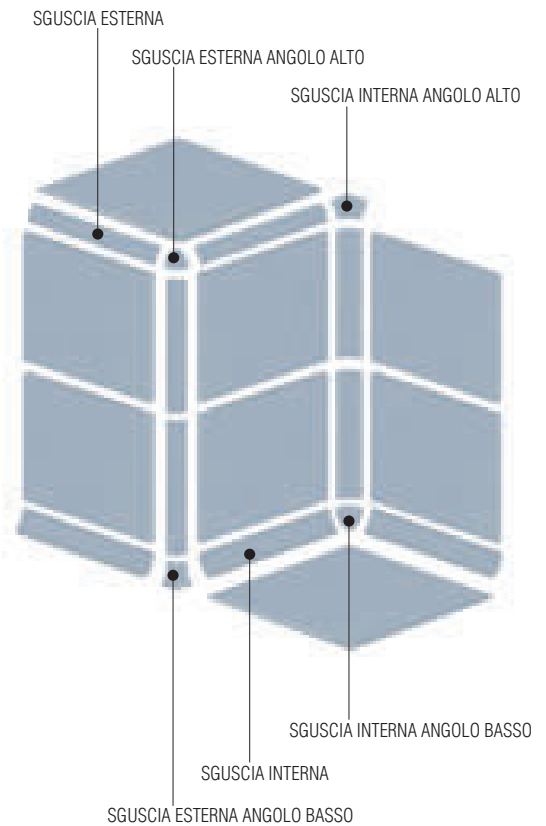

La superficie di vendita M12,5x25 cm è calcolata sulla base della dimensione convenzionale, uguale alla dimensione nominale più una fuga di 5 mm.
Sales area 5"x9"^{nom} calculated on the basis of the standard size, equal to the nominal size plus a 5 mm joint / Verkaufsoberfläche M12,5x25 cm unter der Grundlage konventioneller Abmessungen gleich der Nennabmessungen plus einer Fuge von 5 mm / Surface de vente M12,5x25 cm calculées sur la base de la dimension conventionnelle, égale à la dimension nominale plus joint de 5 mm / La superficie de venta M12,5x25 cm se calcula sobre la base de tamaño convencional, igual al tamaño nominal más una distancia de separación de 5 mm.

H₂O SPORT PROJECT

Pezzi speciali / Special trims / Sonderstücke / Pieces speciales / Piezas especiales



BORDO VASCA RIGATO
M12,5x25
5"x10"

ANG. B. VASCA RIGATO
M12,5x12,5
5"x5"

BORDO VASCA RIGATO CON B.C. BLU SMALTATO
M12,5x25
5"x10"

ANG. ESTERNO B. VASCA RIGATO CON B.C. BLU SMALTATO
M12,5x12,5
5"x5"

ANG. INTERNO B. VASCA RIGATO CON B.C. BLU SMALTATO
M12,5x12,5
5"x5"

Il bordo blu cobalto è smaltato

The cobalt edge is glazed
Kobaltblau Beckenrand ist glasiert
Le bord de piscine cobalt est émaillé
El bordo de piscina cobalto está esmaltado

CODICE	0003538	0003539	0003540	0003541	0003542
SPESSORE	7,8	7,8	7,8	7,8	7,8

IMBALLI

PACKING / VERPACKUNGEN / EMBALLAGES / EMBALAJES

FORMATO	12,5x25	12,5x12,5	12,5x25	12,5x12,5	12,5x12,5
PEZZI-SCATOLA	32	4	32	1	1
MQ-SC	1	0,06	1	0,03	0,03
SC-PAL	105	-	105	-	-
MQ-PAL	105	-	105	-	-
KG-SC	12,19	0,8	12,19	1,6	1,6
KG-PAL	1279,95	-	1279,95	-	-



CANALE INTERNO DI RICICLO - 90°
M12,5x25
5"x10"

CANALE INTERNO DI RICICLO - 107°
M12,5x25
5"x10"

CANALE DI RACCOLTA
M12,5x25
5"x10"

CANALE DI RACCOLTA E SCARICO
M12,5x25
5"x10"

CANALE DI RACCOLTA TERMINALE
M12,5x25
5"x10"

CANALE DI RACCOLTA ANGOLARE
M12,5x12,5
5"x5"

CODICE	0003518	0003519	0003514	0003515	0003516	0003517
SPESSORE	15	15	20	20	20	20

IMBALLI

PACKING / VERPACKUNGEN / EMBALLAGES / EMBALAJES

FORMATO	12,5x25	12,5x25	12,5x25	12,5x25	12,5x25	12,5x12,5
PEZZI-SCATOLA	16	16	11	11	11	5
MQ-SC	0,5	0,5	0,34	0,34	0,34	0,07
SC-PAL	-	-	120	120	120	-
MQ-PAL	-	-	41,25	41,25	41,25	-
KG-SC	12,16	12,16	6,97	6,53	6,75	1,64
KG-PAL	-	-	836,40	783,60	810	-



INDICATORE DI PROFONDITA'
M12,5x25
5"x10"

INDICATORE DI DIREZIONE
M12,5x25
5"x10"

SEGNALETICA VARIA
M12,5x25
5"x10"

PROFILO IN PVC GR 6/25
2,5x250
1"x100"

PROFILO IN PVC GR 6/35
3,5x250
1¹⁰/₈"x100"

PROFILO IN PVC A L GR 6/L
2,5x250
1"x100"

CODICE	0003521	0003522	0003520	A003574	A003575	A003576
SPESSORE	7,8	7,8	7,8	-	-	-



**PIATTO DOCCIA
BAHIA**
15x15
6"x6"



**PIATTO DOCCIA
WEISS-MIX**
15x15
6"x6"



**BORDO PIATTO
DOCCIA BAHIA**
15x15
6"x6"



**BORDO PIATTO
DOCCIA WEISS-MIX**
15x15
6"x6"



**ANGOLO BORDO PIATTO
DOCCIA BAHIA**
15x15
6"x6"



**ANGOLO BORDO PIATTO
DOCCIA WEISS-MIX**
15x15
6"x6"

CODICE	0003523	0003524	0003525	0003526	0003527	0003528
SPESSORE			-	-	-	-

IMBALLI

PACKING / VERPACKUNGEN / EMBALLAGES / EMBALAJES

FORMATO	15x15	15x15	15x15	15x15	15x15	15x15
PEZZI-SCATOLA	22	22	8	8	2	2
MQ-SC	0,49	0,49	0,18	0,18	0,04	0,04
SC-PAL	116	116	-	-	-	-
MQ-PAL	57,42	57,42	-	-	-	-
KG-SC	8,5	8,5	4,6	4,6	1,3	1,3
KG-PAL	986	986	-	-	-	-

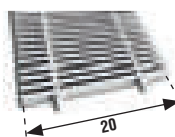

***GRIGLIA
PERPENDICOLARE
GR2/25**
20x250
8"x100"

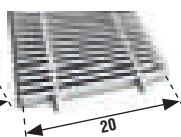

***GRIGLIA
PERPENDICOLARE
GR2/35**
20x250
8"x100"

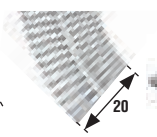

***GRIGLIA
PERPENDICOLARE
CURVABILE GR2/25/C**
20x250
8"x100"

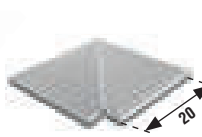

**ANGOLO GRIGLIA
PERPENDICOLARE
GR2/25**
20x20
8"x8"

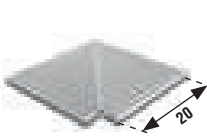

**ANGOLO GRIGLIA
PERPENDICOLARE
GR2/35**
20x20
8"x8"

CODICE	A003474	A003480	A003477	A003489	A003572
SPESSORE					

* Griglia fornita in tronchi standard di 2,5 m

Roll-up supplied in standard sections
2,5 m in length
Rollrost Lieferung in Standardlängen
von 2,5 m
Grille fournie en tronçons standard de
2,5 m de longueur
Rejilla suministrada en módulos
estandar de 2,5 m de longitud

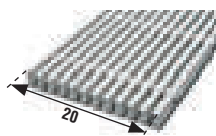

****GRIGLIA PARALLELA
GR20**
20x100
8"x40"

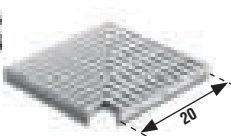

**ANGOLO GRIGLIA
PARALLELA GR20**
20x20
8"x8"



****GRIGLIA
CURVABILE GR47**
20x100
8"x40"

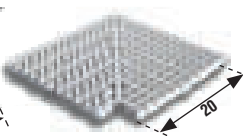

**ANGOLO GRIGLIA
CURVABILE GR47**
20x20
8"x8"

CODICE	A003483	A003637	A003486	A003573
SPESSORE				

** Griglia fornita in tronchi standard di 1 m

Roll-up supplied in standard sections 1 m in length
Rollrost Lieferung in Standardlängen von 1 m
Grille fournie en tronçons standard de 1 m de longueur
Rejilla suministrada en módulos estandar de 1 m de longitud



**A003537
PILETTA ABS IN PLASTICA GR63**
Ø11^{mm} - 26 l/min

H₂O SPORT PROJECT

Gres porcellanato smaltato EN 14411 Bla / Glazed porcelain stoneware / Glasiertes Feinsteinzeug / Grès cérame émaillé / Gres porcelánico esmaltado

SISTEMA FINLANDESE / FINNISH SYSTEM / FINNISCHE SYSTEM / SYSTÈME FINLANDAIS / SISTEMA FINLANDÉS



Imballi / Packing / Verpackungen / Emballages / Embalajes

Formato	Pezzi/Sc.	Mq/Sc	Kg/Sc	
Size	Pcs/Box	Sq.M/Box	Kg/Box	
Format	Pcs/Ctn	Mq/Ctn	Kg/Ctn	
Grösse	Stck/Kart	Qm/Kart	Kg/Kart	
Tamaño	Piezas/Caja	Mq/Caja	Kg/Caja	
12,5x25	12	0,37	6,94	①
12,5x12,5	5	0,07	1,54	②
12,5x12,5	5	0,07	1,44	③



②
15
0003530
Angolo esterno bordo vasca
M12,5x12,5 / 5"x5"

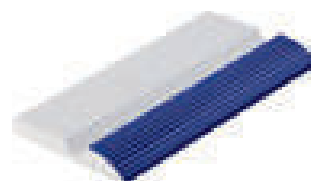

①
15
0003529
Bordo vasca
M12,5x25 / 5"x10"

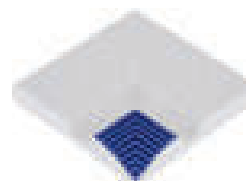

③
15
0003531
Angolo interno bordo vasca
M12,5x12,5 / 5"x5"

SISTEMA ZURIGO / ZURICH SYSTEM / ZÜRICH SYSTEM / SYSTÈME ZURICH / SISTEMA DE ZURICH



Imballi / Packing / Verpackungen / Emballages / Embalajes

Formato	Pezzi/Sc.	Mq/Sc	Kg/Sc	
Size	Pcs/Box	Sq.M/Box	Kg/Box	
Format	Pcs/Ctn	Mq/Ctn	Kg/Ctn	
Grösse	Stck/Kart	Qm/Kart	Kg/Kart	
Tamaño	Piezas/Caja	Mq/Caja	Kg/Caja	
12,5x25	10	0,3	12	①
12,5x12,5	1	0,01	1,6	②
12,5x12,5	1	0,01	0,56	③



②
15
0003494
Angolo esterno bordo vasca
M12,5x12,5 / 5"x5"

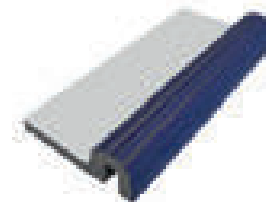

①
15
0003493
Bordo vasca
M12,5x25 / 5"x10"



③
15
0003495
Angolo interno bordo vasca
M12,5x12,5 / 5"x5"

Il bordo blu cobalto è smaltato

The cobalt edge is glazed / Kobaltblau Beckenrand ist glasiert / Le bord de piscine cobalt est émaillé / El bordo de piscina cobalto está esmaltado



La superficie di vendita M12,5x25 cm è calcolata sulla base della dimensione convenzionale, uguale alla dimensione nominale più una fuga di 5 mm.

Sales area 5"x9^{7/8"} calculated on the basis of the standard size, equal to the nominal size plus a 5 mm joint / Verkaufsoberfläche M12,5x25 cm unter der Grundlage konventioneller Abmessungen gleich der Nennabmessungen plus einer Fuge von 5 mm / Surface de vente M12,5x25 cm calculées sur la base de la dimension conventionnelle, égale à la dimension nominale plus joint de 5 mm / La superficie de venta M12,5x25 cm se calcula sobre la base de tamaño convencional, igual al tamaño nominal más una distancia de separación de 5 mm.

SISTEMA WIESBADEN / WIESBADEN SYSTEM / WIESBADEN SYSTEM / SYSTÈME WIESBADEN / SISTEMA DE WIESBADEN

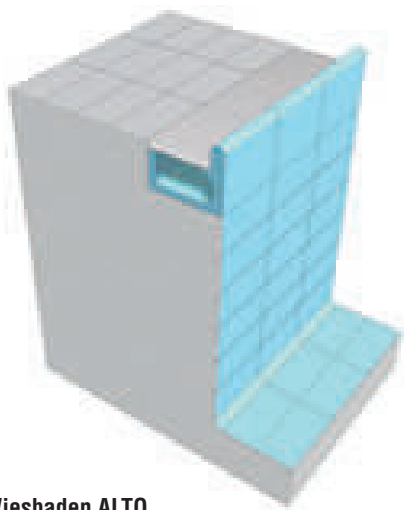

Wiesbaden ALTO

Imballi / Packing / Verpackungen / Emballages / Embalajes

Formato Size Format Grösse Tamaño	Pezzi/Sc. Pcs/Box Pcs/Ctn Stck/Kart Piezas/Caja	Mq/Sc Sq.M/Box Mq/Ctn Qm/Kart Mq/Caja	Kg/Sc Kg/Box Kg/Ctn Kg/Kart Kg/Caja	
23,8x24,5	1	0,07 / 0,05	6,60	①
23,8x24,5	1	0,07 / 0,05	6,41	②
23,8x23,8	1	0,08 / 0,05	5,58	③
23,8x23,8	1	0,08 / 0,05	5,1	④

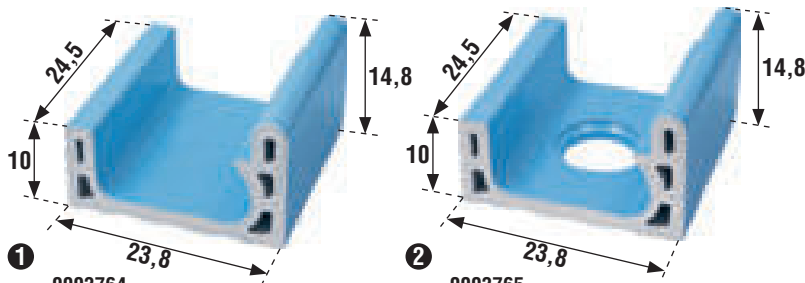

① **0003764**
Canale alto
24,5x23,8 / 10"x9^{1/2"}

② **0003765**
Canale alto con scarico
24,5x23,8 / 10"x9^{1/2"}

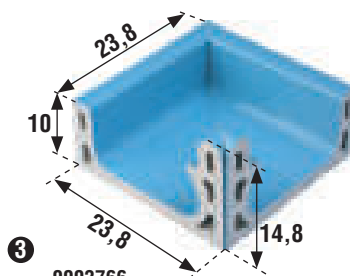

③ **0003766**
Canale alto angolo interno
23,8x23,8 / 9^{1/2"}x9^{1/2"}

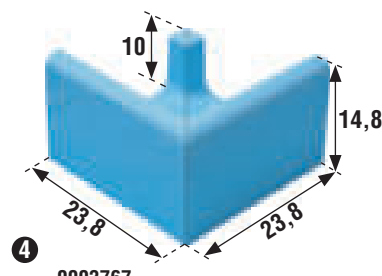

④ **0003767**
Canale alto angolo esterno
23,8x23,8 / 9^{1/2"}x9^{1/2"}

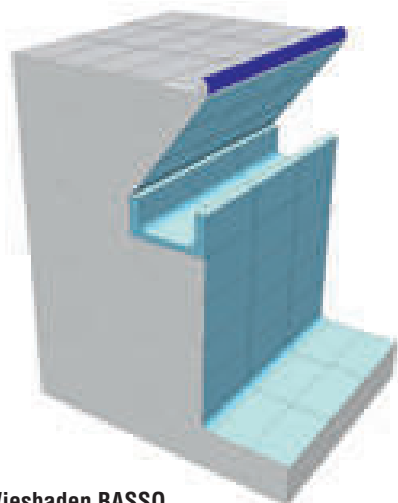

Wiesbaden BASSO

Imballi / Packing / Verpackungen / Emballages / Embalajes

Formato Size Format Grösse Tamaño	Pezzi/Sc. Pcs/Box Pcs/Ctn Stck/Kart Piezas/Caja	Mq/Sc Sq.M/Box Mq/Ctn Qm/Kart Mq/Caja	Kg/Sc Kg/Box Kg/Ctn Kg/Kart Kg/Caja	
23,5x24,5	1	0,05 / 0,03	5,02	①
23,5x24,5	1	0,05 / 0,03	5,02	②
23,5x23,5	1	0,03 / 0,01	5,1	③
23,5x23,5	1	0,03 / 0,01	5,1	④

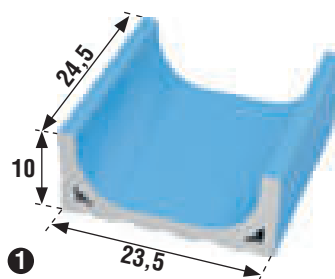

① **0003532**
Canale basso
24,5x23,5 / 10"x9^{1/4"}

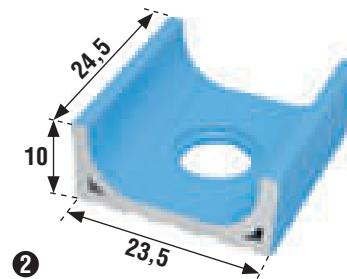

② **0003533**
Canale basso con scarico
24,5x23,5 / 10"x9^{1/4"}

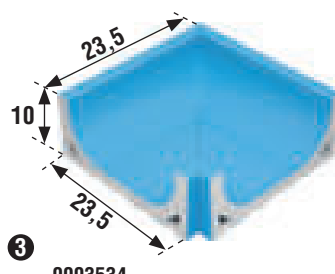

③ **0003534**
Canale basso angolo interno
23,5x23,5 / 9^{1/4"}x9^{1/4"}

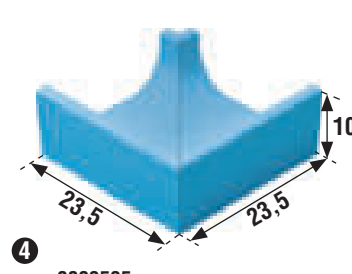

④ **0003535**
Canale basso angolo esterno
23,5x23,5 / 9^{1/4"}x9^{1/4"}

H₂O SPORT PROJECT

Gres porcellanato smaltato EN 14411 Bla / Glazed porcelain stoneware / Glasiertes Feinsteinzeug / Grès cérame émaillé / Gres porcelánico esmaltado



Sistema Finlandese



Bianco Nat. Matt 12,5x25
Azzurro Caraibico Nat. Matt 12,5x25
Azzurro Caraibico B Matt 12,5x25
Sguscia esterna Bianco 3x25



CERDISASTONE



altaj

Gres porcellanato colorato in massa

Colorbody porcelain stoneware / Durghgefärbtes Steinzeug / Grès cérame coloré dans le masse / Gres porcelánico coloreado en toda la masa

UNI EN 14411 G B1a



Bronzo



Formati / Sizes / Grösse / Format / Tamaño:

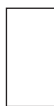

30x60
30x60 Rett.
12"x24"

Superfici / Surface / Oberfläche / Surface / Superficie



NATURALE / NATURAL / NATUR / NATUREL / NATURAL

altaj

Gres porcellanato colorato in massa

Colorbody porcelain stoneware / Durghgefärbtes Steinzeug / Grès cérame coloré dans la masse / Gres porcelánico coloreado en toda la masa

UNI EN 14411 G Bla

Grigio Chiaro

Grigio Scuro

Nero

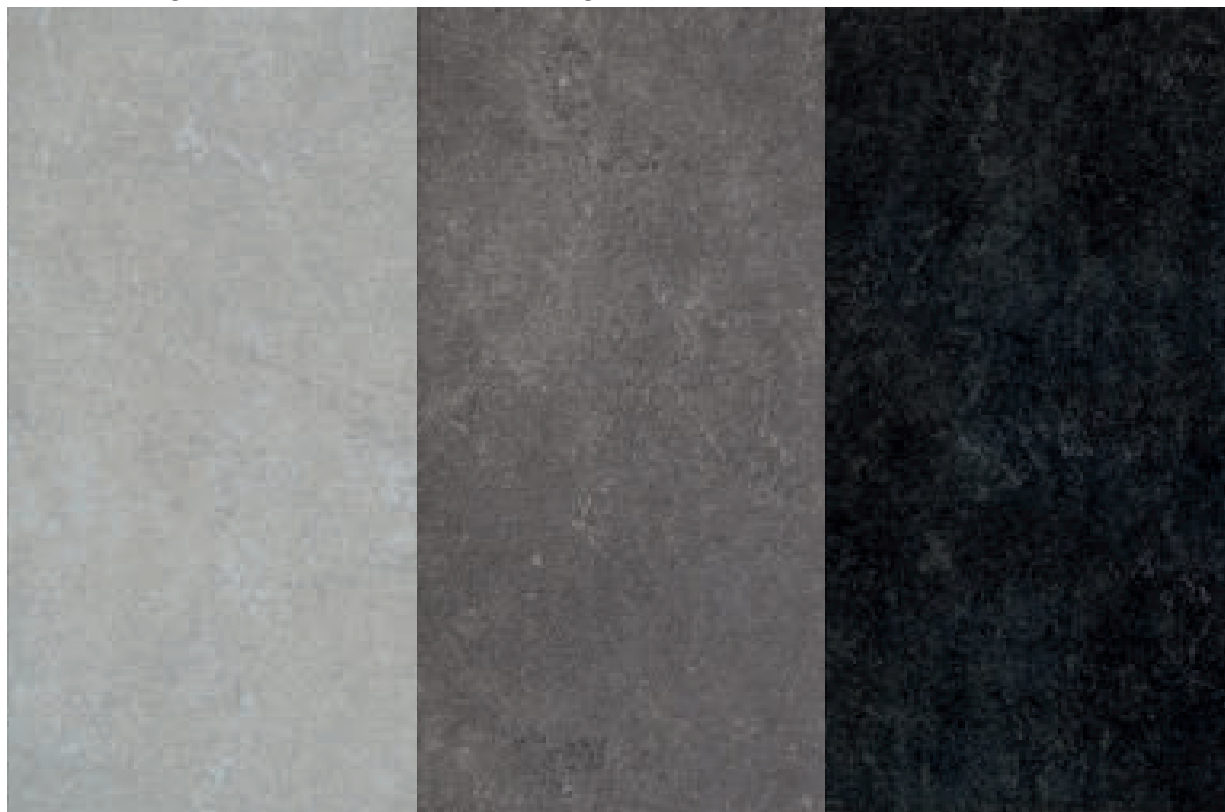

NATURALE
NATURAL / NATUR / NATUREL / NATURAL



30x60
12"x24"



30x60 Rett.
12"x24"



BATTISCOPA
7x60
2³/₄"x24"
14 pcs x box

NATURALE

NATURAL / NATUR / NATUREL / NATURAL

Grigio Chiaro	0077507	0077517
Grigio Scuro	0077506	0077516
Nero	0077505	0077515
Beige	0077509	0077519
Bronzo	0077508	0077518

NATURALE

NATURAL / NATUR / NATUREL / NATURAL

Grigio Chiaro	0077277
Grigio Scuro	0077276
Nero	0077275
Beige	0077279
Bronzo	0077278

Beige

Bronzo



NATURALE
 NATURAL / NATUR / NATUREL / NATURAL

Imballi / Packing / Verpackungen / Emballages / Embalajes

Formato	Pezzi/Sc.	Mq/Sc	Sc/Pal	Mq/Pal	Kg/Sc	Kg/Pal
Size	Pcs/Box	Sq.M/Box	Box/Pal	Sq.M/Pal	Kg/Box	Kg/Pal
Größe	Pcs/Ctn	Mq/Ctn	Ctn/Pal	Mq/Pal	Kg/Ctn	Kg/Pal
Format	Stck/Kart	Qm/Kart	Kart/Pal	Qm/Pal	Kg/Kart	Kg/Pal
Tamaño	Piezas/Caja	Mq/Caja	Caja/Pal	Mq/Pal	Kg/Caja	Kg/Pal
30x60	8	1,44	32	46,10	31,5	1008,00
7x60 battiscopa	14	0,59	63	37,17	15	945

cementi

Gres porcellanato colorato in massa

Colorbody porcelain stoneware / Durghgefärbtes Steinzeug / Grès cérame coloré dans le masse / Gres porcelánico coloreado en toda la masa

UNI EN 14411 G B1a



Antracite Rett. 60x60



Formati / Sizes / Grösse / Format / Tamaño:



60,8x60,8
60x60 Rett.
24"x24"

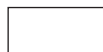

30x60
30x60 Rett.
12"x24"



Fango Rett. 60x60

cementi

Gres porcellanato colorato in massa

Colorbody porcelain stoneware / Durghgefärbtes Steinzeug / Grès cérame coloré dans la masse / Gres porcelánico coloreado en toda la masa

UNI EN 14411 G Bla

Bianco



Grigio



Antracite



Avorio



Fango



Nero

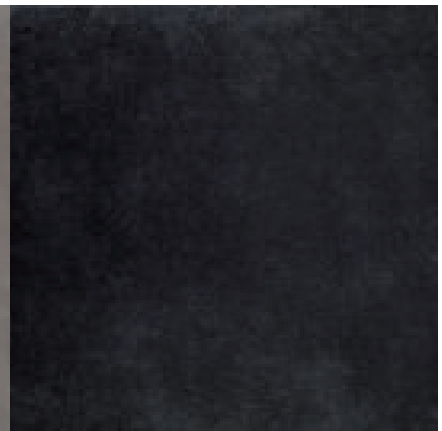

* Solo i formati 60x60 e 30x60 rettificati sono modulari tra loro con fuga 2 mm.

Only rectified sizes 60x60 and 30x60 can be used in modular combinations, with 2 mm joint / Nur die rektifizierten Formate 60x60 und 30x60 passen mit 2-mm-Fuge modular zueinander
Seuls les formats 60x60 et 30x60 rectifiés peuvent se combiner (avec joint de 2 mm) / Sólo los formatos de 60 x 60 y 30 x 60 rectificados se pueden combinar entre sí, dejando juntas de 2 mm

** Il 30x60 naturale non è modulare con il 60,8x60,8 e con i formati rettificati.

Natural size 30x60 cannot be used in modular combinations with size 60,8x60,8 or rectified sizes / Das normale Format 30x60 passt nicht modular zum Format 60,8x60,8 und zu den rektifizierten Formaten
Le format 30x60 nat ne peut pas se combiner avec le format 60,8x60,8 et avec les formats rectifiés / El formato de 30 x 60 natural no se puede combinar con el de 60,8 x 60,8 ni con los formatos rectificados

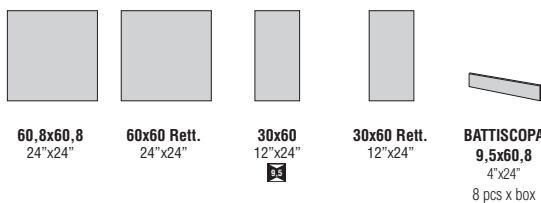

NATURALE

NATURAL / NATUR / NATUREL / NATURAL

	Bianco	0050300	0050301	0050303	0050302	0050305
Grigio	0050320	0050321	0050323	0050322	0050325	
Antracite	0050330	0050331	0050333	0050332	0050335	
Avorio	0050310	0050311	0050313	0050312	0050315	
Fango	0050350	0050351	0050353	0050352	0050355	
Nero	0050360	0050361	0050363	0050362	0050365	

Imballi / Packing / Verpackungen / Emballages / Embalajes

Formato	Pezzi/Sc.	Mq/Sc	Sc/Pal	Mq/Pal	Kg/Sc	Kg/Pal
60,8x60,8	3	1,11	32	35,52	26,20	838,40
60x60 Rett.	3	1,08	32	34,56	25,50	816,00
30x60	8	1,44	32	46,08	32,50	1040,00
30x60 Rett.	6	1,08	32	34,56	24,50	784,00

	Classement			
	U	P	E	C
30x60 Nat. = 9,5 mm	U4	P3	E3	C2
30x60 Rett. = 10,5 mm	U4	P4	E3	C2
60x60 Nat. - Rett.	U4	P4+	E3	C2



Bianco
Avorio



0050304 Mosaico Bianco Rett.
30x30 - 12"x12"
4 pcs x box



0050324 Mosaico Grigio Rett. 30x30
30x30 - 12"x12"
4 pcs x box



0050334 Mosaico Antracite Rett.
30x30 - 12"x12"
4 pcs x box



0050314 Mosaico Avorio Rett.
30x30 - 12"x12"
4 pcs x box



0050354 Mosaico Fango Rett.
30x30 - 12"x12"
4 pcs x box



0050364 Mosaico Nero Rett.
30x30 - 12"x12"
4 pcs x box



0076769 Fascia Mosaico Acciaio 4x30 - 1 1/4"x12"
6 pcs x box

0050370 Matita Alluminio 1x60 - 1/2"x24"
8 pcs x box

Mosaico Grigio Rett. 30x30
Grigio Rett. 30x60
Grigio Rett. 60x60

chalet

Gres porcellanato colorato in massa

Colorbody porcelain stoneware / Durghgefärbtes Steinzeug / Grès cérame coloré dans la masse / Gres porcelánico coloreado en toda la masa

UNI EN 14411 G BIa



Rovere Grip 20x80
Rovere Grip 13x80



Formati / Sizes / Grösse / Format / Tamaño:



20x80 Rett.
8"x32"



13x80 Rett.
5^{1/8}"x32"

Superfici / Surface / Oberfläche / Surface / Superficie



NATURALE / NATURAL / NATUR / NATUREL / NATURAL



GRIP / GRIP / GRIP OBERFLÄCHE / GRIP / ANTIDESLIZANTE

chalet

Gres porcellanato colorato in massa

Colorbody porcelain stoneware / Durghgefärbtes Steinzeug / Grès cérame coloré dans le masse / Gres porcelánico coloreado en toda la masa

UNI EN 14411 G Bla



Bianco Rett. 20x80
Bianco Grip 20x80



Nero Rett. 13x80

chalet

Gres porcellanato colorato in massa

Colorbody porcelain stoneware / Durhgefärbtes Steinzeug / Grès cérame coloré dans le masse / Gres porcelánico coloreado en toda la masa

UNI EN 14411 G Bla

NATURALE

NATURAL / NATUR / NATUREL / NATURAL

GRIP

GRIP SURFACE / SURFACE GRIP
/ GRIP OBERFLÄCHE / ANTIDESLIZANTE

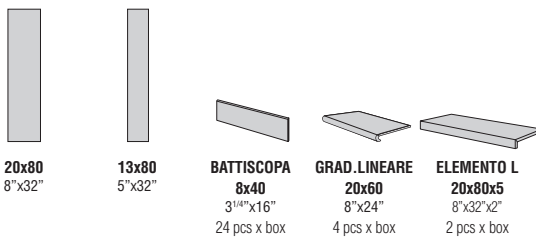

NATURALE

NATURAL / NATUR / NATUREL / NATURAL

Bianco	0040202	0040201	0040203	0040204	-
Rovere	0040222	0040221	0040223	0040224	-
Ciliegio	0040242	0040241	0040243	0040244	-
Nero	0040262	0040261	0040263	0040264	-

GRIP

GRIP / GRIP OBERFLÄCHE / GRIP / ANTIDESLIZANTE

Bianco	0040212	0040211	-	-	0040213
Rovere	0040232	0040231	-	-	0040233
Ciliegio	0040252	0040251	-	-	0040253
Nero	0040272	0040271	-	-	0040273

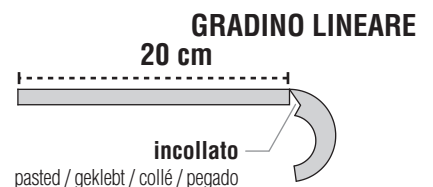
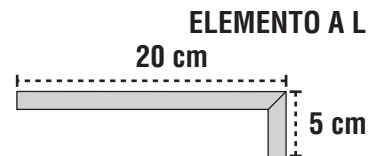

Avvertenze per la posa: si consiglia la posa a corrono del materiale, sfalsando il lato più lungo per massimo 15 cm sulla lunghezza del pezzo adiacente. Utilizzare una fuga di minimo 2 mm.

Attention when laying: we recommend laying in a brick pattern, staggering the slats so that the longer side is offset a maximum of 15 cm against its neighbour. Leave a minimum 2 mm gap between slats.
Hinweise für die Verlegung: Es wird die fortlaufende Verlegung des Materials empfohlen, mit Versetzung der Längsseite um maximal 15 cm zum anliegenden Teil. Eine Fuge von mindestens 2 mm vorsehen.
Avertissement pour la pose : une pose à l'anglaise du matériau est conseillée, en décalant le côté le plus long de 15 cm maximum sur la longueur de l'élément adjacent. Utiliser un joint d'au moins 2 mm.
Advertencia para la colocación: aconsejamos la colocación del material a junta partida, escalonando el lado más largo como máximo 15 cm sobre la longitud de la pieza contigua. Utilícese una junta de 2 mm como mínimo.

Imballi / Packing / Verpackungen / Embalajes / Embalajes

Formato	Pezzi/Sc.	Mq/Sc	Sc/Pal	Mq/Pal	Kg/Sc	Kg/Pal
Size	Pcs/Box	Sq.M/Box	Box/Pal	Sq.M/Pal	Kg/Box	Kg/Pal
Größe	Pcs/Ctn	Mq/Ctn	Ctn/Pal	Mq/Pal	Kg/Ctn	Kg/Pal
Format	Stk/Kart	Qm/Kart	Kart/Pal	Qm/Pal	Kg/Kart	Kg/Pal
Tamaño	Piezas/Caja	Mq/Caja	Caja/Pal	Mq/Pal	Kg/Caja	Kg/Pal
20x80	8	1,28	48	61,44	28,0	1296,0
13x80	12	1,25	54	67,50	27,5	1425,6

NF	UPEC	Classement			
		U	P	E	C
20x80 Nat.	U4	P3	E3	C2	S
20x80 Grip	U4	P3	E3	C2	S



Naturale > 0,60 dry / > 0,60 wet
Grip > 0,60 dry / da 0,50 a 0,60 wet

BOT 3000
ANSI A 137.1:2012
DCOF > 0,42



Ciliegio Rett. 20x80
Ciliegio Rett. 13x80

grange

Gres porcellanato colorato in massa

Colorbody porcelain stoneware / Durghgefärbtes Steinzeug / Grès cérame coloré dans le masse / Gres porcelánico coloreado en toda la masa

UNI EN 14411 G BIa



Gravel Lapp. Rett. 50x50 + decoro



Formati / Sizes / Grösse / Format / Tamaño:



50x100
20"x40"



50x50
20"x20"



33,3x50
13"x20"



33,3x33,3
13"x13"



16,5x33,3
6 1/2"x13"

Superfici / Surface / Oberfläche / Surface / Superficie

NATURALE / NATURAL / NATUR / NATUREL / NATURAL

LAPPATO / SEMI-POLISHED / LEICHT POLIERT / SEMI-POLI / PULIDO

GRIP / GRIP / GRIP OBERFLÄCHE / GRIP / ANTIDESLIZANTE

grange

Gres porcellanato colorato in massa

Colorbody porcelain stoneware / Durghgefärbtes Steinzeug / Grès cérame coloré dans le masse / Gres porcelánico coloreado en toda la masa

UNI EN 14411 G BIa



Path Lapp. Rett. 50x100



Path Lapp. Rett. 50x100

grange

Gres porcellanato colorato in massa

Colorbody porcelain stoneware / Durghgefärbtes Steinzeug / Grès cérame coloré dans le masse / Gres porcelánico coloreado en toda la masa

UNI EN 14411 G B1a

Path

Gravel

Embers

Wheat

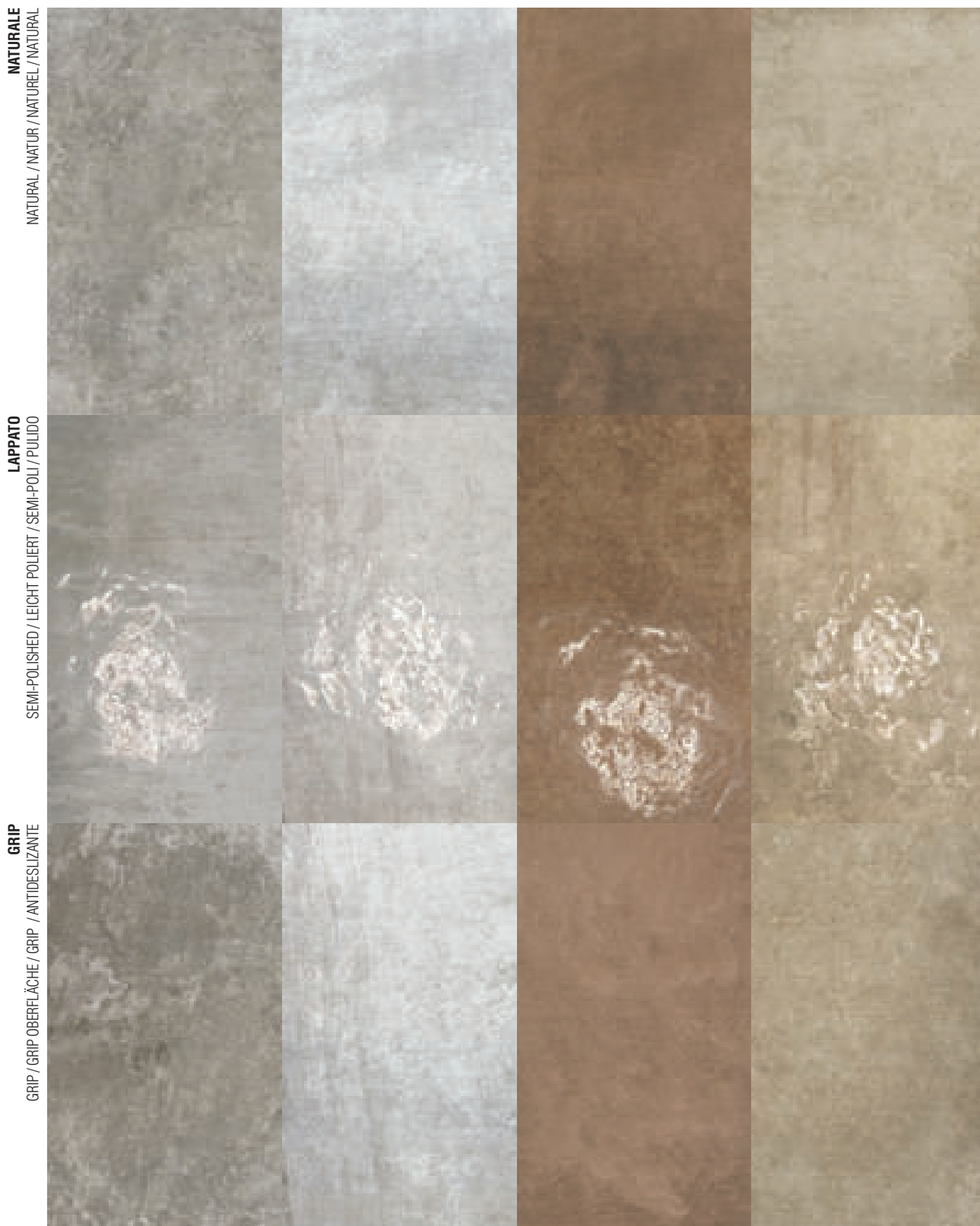



PENDULUM TEST BS 7976
Grip > 36 dry / > 36 wet



ASTM C 1028
Naturale > 0,60 dry / > 0,60 wet
Grip > 0,60 dry / da 0,50 a 0,60 wet



BOT 3000
ANSI A 137.1:2012
DCOF ≥ 0,42

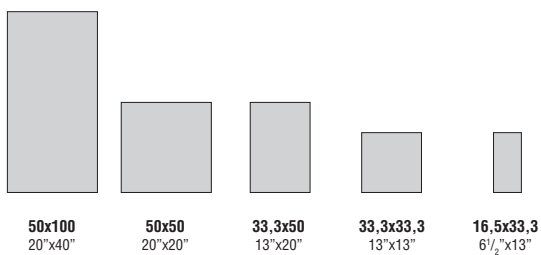

NATURALE

NATURAL / NATUR / NATUREL / NATURAL

Path	0025850	0025851	0025852	0025853	0025855
Gravel	0025825	0025826	0025827	0025828	0025830
Embers	0025875	0025876	0025877	0025878	0025880
Wheat	0025800	0025801	0025802	0025803	0025805

LAPPATO

SEMI-POLISHED / LEICHT POLIERT / SEMI-POLI / PULIDO

Path	0025863	0025864
Gravel	0025838	0025839
Embers	0025888	0025889
Wheat	0025813	0025814

GRIP

GRIP / GRIP OBERFLÄCHE / GRIP / ANTIDESLIZANTE

Path	0025865	0025866	0025867	0025868	0025871
Gravel	0025840	0025841	0025842	0025843	0025846
Embers	0025890	0025891	0025892	0025893	0025896
Wheat	0025815	0025816	0025817	0025818	0025821



Wheat Nat. Grip 50x50_33,3x50
33,3x33,3_16,5x33,3

CERDISASTONE

grange

Gres porcellanato colorato in massa

Colorbody porcelain stoneware / Durghgefärbtes Steinzeug / Grès cérame coloré dans la masse / Gres porcelánico coloreado en toda la masa

UNI EN 14411 G BIa



Embers nat 50x50 / 33,3x50 / 33,3x33,3

	33,3x33,3 cm	33,3x50 cm	50x50 cm
N° pezzi per modulo N° pieces for module	2	2	2
% mq	21,03%	31,57%	47,40%

	Naturale	Grip
Path	GRN3APA	GRG3APA
Gravel	GRN3AGR	GRG3AGR
Embers	GRN3AEM	GRG3AEM
Wheat	GRN3AWH	GRG3AWH

Modulo 3A

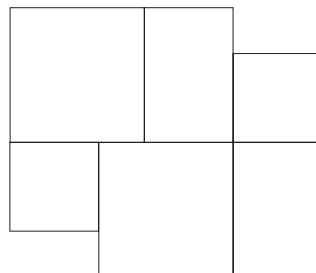

	33,3x33,3 cm	33,3x50 cm	50x50 cm	50x100 cm
N° pezzi per modulo N° pieces for module	1	2	1	1
% mq	9,29%	27,88%	20,94%	41,88%

	Naturale	Grip
Path	GRN4APA	GRG4APA
Gravel	GRN4AGR	GRG4AGR
Embers	GRN4AEM	GRG4AEM
Wheat	GRN4AWH	GRG4AWH



PENDULUM TEST BS 7976
Grip > 36 dry / > 36 wet

ASTM C 1028
Naturale > 0,60 dry / > 0,60 wet
Grip > 0,60 dry / da 0,50 a 0,60 wet

BOT 3000
ANSI A 137.1:2012
DCOF ≥ 0,42



Modulo 3B

	33,3x33,3 cm	33,3x50 cm	50x50 cm
N° pezzi per modulo N° pieces for module	3	2	1
% mq	36,33%	36,37%	27,30%

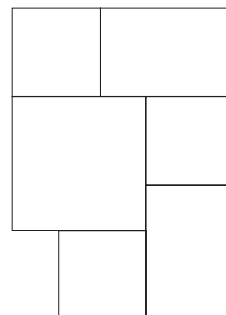

	Naturale	Grip
Path	GRN3BPA	GRG3BPA
Gravel	GRN3BGR	GRG3BGR
Embers	GRN3BEM	GRG3BEM
Wheat	GRN3BWH	GRG3BWH

Modulo 3C

	16,5x33,3 cm	33,3x33,3 cm	33,3x50 cm
N° pezzi per modulo N° pieces for module	2	2	2
% mq	16,53%	33,37%	50,10%

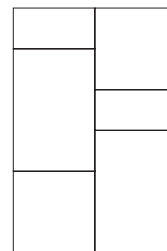

	Naturale	Grip
Path	GRN3CPA	GRG3CPA
Gravel	GRN3CGR	GRG3CGR
Embers	GRN3CEM	GRG3CEM
Wheat	GRN3CWH	GRG3CWH

Modulo 4A

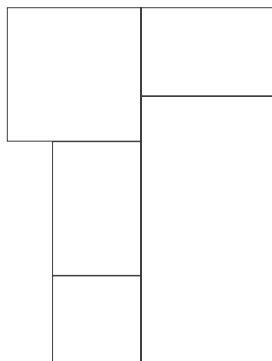

	16,5x33,3 cm	33,3x33,3 cm	33,3x50 cm	50x50 cm
N° pezzi per modulo N° pieces for module	1	1	1	1
% mq	9,44%	19,04%	28,59%	42,93%

	Naturale	Grip
Path	GRN4BPA	GRG4BPA
Gravel	GRN4BGR	GRG4BGR
Embers	GRN4BEM	GRG4BEM
Wheat	GRN4BWH	GRG4BWH

Modulo 4B

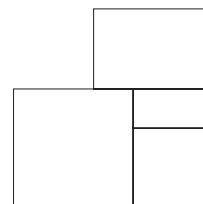

grange

Gres porcellanato colorato in massa

Colorbody porcelain stoneware / Durghgefärbtes Steinzeug / Grès cérame coloré dans la masse / Gres porcelánico coloreado en toda la masa

UNI EN 14411 G Bla



0025809 WHEAT angolo
50x50 - 20"x20"



0025810 WHEAT fascia
50x50 - 20"x20"



0025811 WHEAT inserto
50x50 - 20"x20"



0025884 Gravel angolo
50x50 - 20"x20"



0025885 Gravel fascia
50x50 - 20"x20"

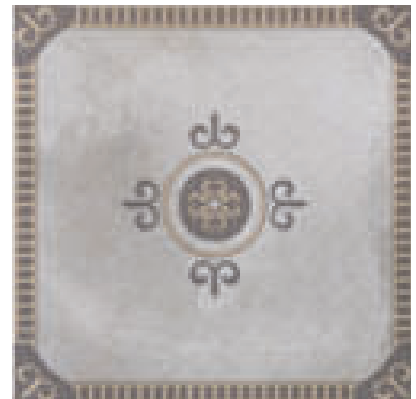

0025886 Gravel inserto
50x50 - 20"x20"

Imballi / Packing / Verpackungen / Emballages / Embalajes

Formato	Pezzi/Sc.	Mq/Sc	Sc/Pal	Mq/Pal	Kg/Sc	Kg/Pal
Size	Pcs/Box	Sq.M/Box	Box/Pal	Sq.M/Pal	Kg/Box	Kg/Pal
Grösse	Pcs/Ctn	Mq/Ctn	Ctn/Pal	Mq/Pal	Kg/Ctn	Kg/Pal
Format	Stck/Kart	Qm/Kart	Kart/Pal	Qm/Pal	Kg/Kart	Kg/Pal
Tamaño	Piezas/Caja	Mq/Caja	Caja/Pal	Mq/Pal	Kg/Caja	Kg/Pal
50x100 nat / grip	3	1,5	30	45	36	1080
50x100 lap	3	1,5	30	45	35,2	1056
50x50 nat / grip	6	1,5	24	36	36	864
50x50 lap	6	1,5	24	36	35,2	844,8
33,3x50 nat / grip	6	1	48	48	23,7	1137,6
33,3x33,3	10	1,11	46	51,06	26	1196
16,5x33,3	17	0,93	56	52,08	22,1	1237,6



PENDULUM TEST BS 7976
Grip > 36 dry / > 36 wet



ASTM C 1028
Naturale > 0,60 dry / > 0,60 wet
Grip > 0,60 dry / da 0,50 a 0,60 wet



BOT 3000
ANSI A 137.1:2012
DCOF ≥ 0,42

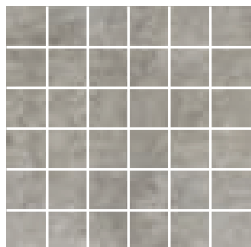

0025857 Mosaico Path
33,3x33,3 - 13"x13"
tessera 5x5 - 2"x2"

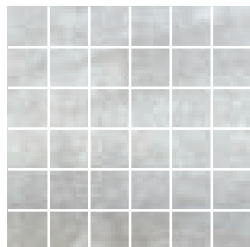

0025832 Mosaico Gravel
33,3x33,3 - 13"x13"
4 pcs x box

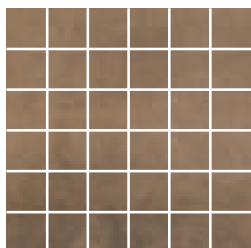

0025882 Mosaico Embers
33,3x33,3 - 13"x13"
tessera 5x5 - 2"x2"

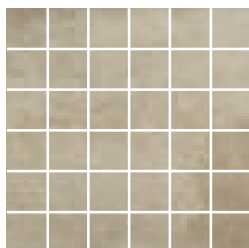

0025807 Mosaico Wheat
33,3x33,3 - 13"x13"
tessera 5x5 - 2"x2"

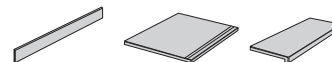

BATTISCOPIA
9,5x50
37/8"x20"

GRADINO INCISO
33,3x33,3
13"x13"

ELEMENTO L
16,5x33,3x5
61/2"x13"x2"

NATURALE

NATURAL / NATUR / NATUREL / NATURAL

Path	0025872	0025858	..
Gravel	0025847	0025833	..
Embers	0025897	0025883	..
Wheat	0025822	0025808	..

LAPPATO

SEMI-POLISHED / LEICHT POLIERT / SEMI-POLI / PULIDO

Path	0025873
Gravel	0025848
Embers	0025898
Wheat	0025823

GRIP

GRIP / GRIP OBERFLÄCHE / GRIP / ANTIDESLIZANTE

Path	0025869
Gravel	0025844
Embers	0025894
Wheat	0025819



home teak

Gres porcellanato colorato in massa

Colorbody porcelain stoneware / Durghgefärbtes Steinzeug / Grès cérame coloré dans la masse / Gres porcelánico coloreado en toda la masa

UNI EN 14411 G BIa



London Teak Nat. Rett. 16,5x100 / 25x100
Mosaico 3D Veneziana Cloud Teak 25x100



Formati / Sizes / Grösse / Format / Tamaño:

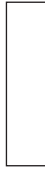

25x100 Rett.
10"x40"



16,5x100 Rett.
6^{1/2}"x40"

Superfici / Surface / Oberfläche / Surface / Superficie



NATURALE / NATURAL / NATUR / NATUREL / NATURAL

GRIP / GRIP / GRIP OBERFLÄCHE / GRIP / ANTIDESLIZANTE

home teak

Gres porcellanato colorato in massa

Colorbody porcelain stoneware / Durghgefärbtes Steinzeug / Grès cérame coloré dans la masse / Gres porcelánico coloreado en toda la masa

UNI EN 14411 G Bia



Honey Teak Nat. Rett. 16,5x100
Honey Teak Grip 16,5x100



Mosaico 3D Veneziana Honey Teak 25x100

home teak

Gres porcellanato colorato in massa

Colorbody porcelain stoneware / Durghgefärbtes Steinzeug / Grès cérame coloré dans la masse / Gres porcelánico coloreado en toda la masa

UNI EN 14411 G B1a

Ice Teak

Cloud Teak

London Teak

Dark Teak

Honey Teak

Cream Teak

NATURALE
NATURAL / NATUR / NATUREL / NATURAL

GRIP
GRIP / GRIP OBERFLÄCHE / GRIP / ANTIDESLIZANTE





PENDULUM TEST
BS 7976
Grip > 36 dry / > 36 wet



BOT 3000
ANSI A 137.1:2012
DCOF ≥ 0,42



ASTM C 1028
Grip > 0,60 dry / > 0,60 wet



25x100 Rett.
10"x40"



16,5x100 Rett.
6 1/2"x40"



BATTISCOPA 8x100
3 1/4"x40"
5 pcs x box

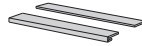

GRAD.
COSTA RETTA
16,5x100x3x3+16,5x100
6 1/2"x40"x1 20"x1 20"+6 1/2"x40"
2 cmp x box

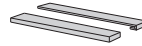

ANG. DX. GRAD.
COSTA RETTA
16,5x100x3x3+16,5x100
6 1/2"x40"x1 20"x1 20"+6 1/2"x40"
2 cmp x box

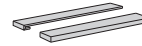

ANG. SX. GRAD.
COSTA RETTA
16,5x100x3x3+16,5x100
6 1/2"x40"x1 20"x1 20"+6 1/2"x40"
2 cmp x box

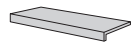

ELEMENTO L
16,5x100x5
6 1/2"x40"x2"
2 pcs x box

NATURALE

NATURAL / NATUR / NATUREL / NATURAL

Ice Teak	0040401	0040402	0040409	0040410	0040411	0040412	-
Cloud Teak	0040511	0040512	0040519	0040520	0040521	0040522	-
London Teak	0040541	0040542	0040549	0040550	0040551	0040552	-
Dark Teak	0040571	0040572	0040579	0040580	0040581	0040582	-
Honey Teak	0040461	0040462	0040469	0040470	0040471	0040472	-
Cream Teak	0040431	0040432	0040439	0040440	0040441	0040442	-

GRIP

GRIP / GRIP OBERFLÄCHE / GRIP / ANTIDESLIZANTE

Ice Teak	0040421	0040422	-	-	-	-	0040423
Cloud Teak	0040531	0040532	-	-	-	-	0040533
London Teak	0040561	0040562	-	-	-	-	0040563
Dark Teak	0040591	0040592	-	-	-	-	0040593
Honey Teak	0040481	0040482	-	-	-	-	0040483
Cream Teak	0040451	0040452	-	-	-	-	0040453

COMPOSIZIONE GRADINO COSTA RETTA

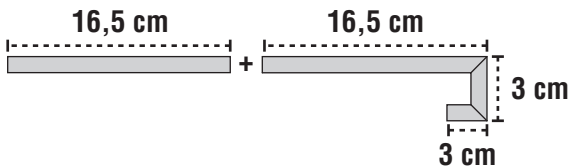

ELEMENTO A L

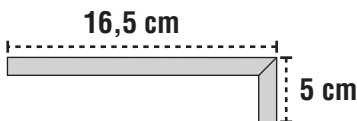

Avvertenze per la posa: si consiglia la posa a correre del materiale, sfalsando il lato più lungo per massimo 20 cm sulla lunghezza del pezzo adiacente. Utilizzare una fuga di minimo 2 mm.

Attention when laying: we recommend laying in a brick pattern, staggering the slats so that the longer side is offset a maximum of 20 cm against its neighbour. Leave a minimum 2 mm gap between slats.

Hinweise für die Verlegung: Es wird die fortlaufende Verlegung des Materials empfohlen, mit Versetzung der Längsseite um maximal 20 cm zum anliegenden Teil. Eine Fuge von mindestens 2 mm vorsehen.

Avertissement pour la pose : une pose à l'anglaise du matériau est conseillée, en décalant le côté le plus long de 20 cm maximum sur la longueur de l'élément adjacent. Utiliser un joint d'au moins 2 mm.

Advertencia para la colocación: aconsejamos la colocación del material a junta partida, escalonando el lado más largo como máximo 20 cm. sobre la longitud de la pieza contigua. Utilícese una junta de 2 mm. como mínimo.

Ice Teak Nat. Rett. 25x100
Decoro Ice Teak Listone 25x100



Imballi / Packing / Verpackungen / Embalajes / Embalajes

Formato	Pezzi/Sc.	Mq/Sc	Sc/Pal	Mq/Pal	Kg/Sc	Kg/Pal
Size	Pcs/Box	Sq.M/Box	Box/Pal	Sq.M/Pal	Kg/Box	Kg/Pal
Größe	Pcs/Ctn	Mq/Ctn	Ctn/Pal	Mq/Pal	Kg/Ctn	Kg/Pal
Format	Stck/Kart	Qm/Kart	Kart/Pal	Qm/Pal	Kg/Kart	Kg/Pal
Tamaño	Piezas/Caja	Mq/Caja	Caja/Pal	Mq/Pal	Kg/Caja	Kg/Pal
25x100	6	1,50	32	48,00	36	1152
16,5x100	9	1,49	36	53,64	35	1260

home teak

Gres porcellanato colorato in massa

Colorbody porcelain stoneware / Durghgefärbtes Steinzeug / Grès cérame coloré dans la masse / Gres porcelánico coloreado en toda la masa

UNI EN 14411 G Bla



0040403 Decoro Ice Teak Listone 25x100 - 10"x40" 2 pcs x box

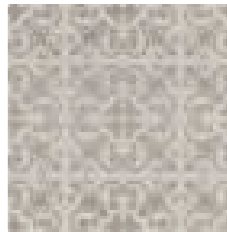

0040404 Decoro Ice Teak Tozzetto 25x25 - 10"x10" *4 MIXED pcs x box



0040543
Decoro London Teak Listone
25x100 - 10"x40" 2 pcs x box

0040544
Decoro London Teak Tozzetto
25x25 - 10"x10" *4 MIXED pcs x box

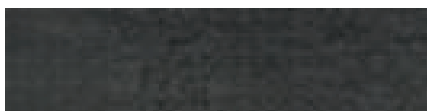

0040573
Decoro Dark Teak Listone
25x100 - 10"x40" 2 pcs x box

0040574
Decoro Dark Teak Tozzetto
25x25 - 10"x10" *4 MIXED pcs x box



0040433
Decoro Cream Teak Listone
25x100 - 10"x40" 2 pcs x box

0040434
Decoro Cream Teak Tozzetto
25x25 - 10"x10" *4 MIXED pcs x box



0040513
Decoro Cloud Teak Listone
25x100 - 10"x40" 2 pcs x box

0040514
Decoro Cloud Teak Tozzetto
25x25 - 10"x10" *4 MIXED pcs x box



0040463
Decoro Honey Teak Listone
25x100 - 10"x40" 2 pcs x box

0040464
Decoro Honey Teak Tozzetto
25x25 - 10"x10" *4 MIXED pcs x box



0040405 Decoro Ice Teak Listone 16,5x100 - 6^{1/2}"x40" 3 pcs x box



0040406 Decoro Ice Teak Tozzetto 16,5x16,5 - 6^{1/2}"x6^{1/2}" *4 MIXED pcs x box



0040545
Decoro London Teak Listone
16,5x100 - 6^{1/2}"x40" 3 pcs x box

0040546
Decoro London Teak Tozzetto
16,5x16,5 - 6^{1/2}"x6^{1/2}" *4 MIXED pcs x box



0040575
Decoro Dark Teak Listone
16,5x100 - 6^{1/2}"x40" 3 pcs x box

0040576
Decoro Dark Teak Tozzetto
16,5x16,5 - 6^{1/2}"x6^{1/2}" *4 MIXED pcs x box



0040435
Decoro Cream Teak Listone
16,5x100 - 6^{1/2}"x40" 3 pcs x box

0040436
Decoro Cream Teak Tozzetto
16,5x16,5 - 6^{1/2}"x6^{1/2}" *4 MIXED pcs x box



0040515
Decoro Cloud Teak Listone
16,5x100 - 6^{1/2}"x40" 3 pcs x box

0040516
Decoro Cloud Teak Tozzetto
16,5x16,5 - 6^{1/2}"x6^{1/2}" *4 MIXED pcs x box



0040465
Decoro Honey Teak Listone
16,5x100 - 6^{1/2}"x40" 3 pcs x box

0040466
Decoro Honey Teak Tozzetto
16,5x16,5 - 6^{1/2}"x6^{1/2}" *4 MIXED pcs x box



Nat.



Grip



Dark Teak



London Teak

PENDULUM TEST
BS 7976
Grip > 36 dry / > 36 wet



BOT 3000
ANSI A 137.1:2012
DCOF ≥ 0,42



ASTM C 1028
Grip > 0,60 dry / > 0,60 wet



0040407 Mosaico 3D Veneziana Ice Teak 22,5x100 - 8^{7/8}"x40" 2 pcs x box



0040547
Mosaico 3D Veneziana London Teak
22,5x100 - 8^{7/8}"x40" 2 pcs x box



0040577
Mosaico 3D Veneziana Dark Teak
22,5x100 - 8^{7/8}"x40" 2 pcs x box



0040437
Mosaico 3D Veneziana Cream Teak
22,5x100 - 8^{7/8}"x40" 2 pcs x box



0040517
Mosaico 3D Veneziana Cloud Teak
22,5x100 - 8^{7/8}"x40" 2 pcs x box



0040467
Mosaico 3D Veneziana Honey Teak
22,5x100 - 8^{7/8}"x40" 2 pcs x box



0040408 Mosaico Listelli Ice Teak 25x50 - 10"x20" 4 pcs x box

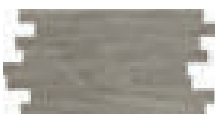

0040548
Mosaico Listelli London Teak
25x50 - 10"x20" 4 pcs x box

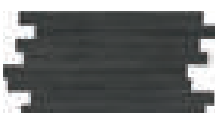

0040578
Mosaico Listelli Dark Teak
25x50 - 10"x20" 4 pcs x box

0040438
Mosaico Listelli Cream Teak
25x50 - 10"x20" 4 pcs x box



0040518
Mosaico Listelli Cloud Teak
25x50 - 10"x20" 4 pcs x box



0040468
Mosaico Listelli Honey Teak
25x50 - 10"x20" 4 pcs x box



*** Tutti i decori TOZZETTO sono inscatolati mescolando in maniera casuale i disegni della piastrella.**

* All the TOZZETTO decorative pieces are boxed randomly to mix the patterns on the tiles.

* Beim Verpacken aller Dekore TOZZETTO wurden die Zeichnungen der Fliese nach dem Zufallsprinzip gemischt.

* Tous les décors TOZZETTO sont mis en boîte en mélangeant de manière aléatoire les motifs du carrelage.

* Todas las decoraciones TOZZETTO se presentan en estuches con los dibujos de la baldosa mezclados al azar.

natura

Gres porcellanato colorato in massa

Colorbody porcelain stoneware / Durghgefärbtes Steinzeug / Grès cérame coloré dans le masse / Gres porcelánico coloreado en toda la masa

UNI EN 14411 G BIa



Mogano 15x120 20x120



Formati / Sizes / Grösse / Format / Tamaño:

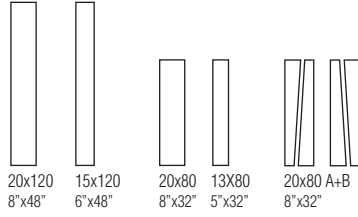

Superfici / Surface / Oberfläche / Surface / Superficie



natura

Gres porcellanato colorato in massa

Colorbody porcelain stoneware / Durghgefärbtes Steinzeug / Grès cérame coloré dans la masse / Gres porcelánico coloreado en toda la masa

UNI EN 14411 G BIa



Selva Nat. Rett. 15x120_ 20x120



Ulivo Grip Rett. 20x80

natura

Gres porcellanato colorato in massa

Colorbody porcelain stoneware / Durghgefärbtes Steinzeug / Grès cérame coloré dans la masse / Gres porcelánico coloreado en toda la masa

UNI EN 14411 G Bia

Abete Bianco

Frassino

Mogano

Multicolor

Selva

Ulivo



NATURALE
NATURAL / NATUR / NATUREL / NATURAL

GRIP
GRIP / GRIP OBERFLÄCHE / GRIP / ANTIDESLIZANTE



9.5
20x80
13x80

10.5
20x120
15x120

R9
Nat.

R11
A+B+C
Grip



V4

PENDULUM TEST BS 7976
Grip > 36 dry / > 36 wet



ASTM C 1028
Nat > 0,60 dry / > 0,60 wet
Grip > 0,60 dry / > 0,60 wet



BOT 3000
ANSI A 137.1:2012
DCOF ≥ 0.42



20x120
8"x48"
± 10,5



15x120
6"x48"
± 10,5



20x80
8"x32"
± 9,5



13x80
5"x32"
± 9,5



20x80 A+B
8"x32"
± 9,5

NATURALE

NATURAL / NATUR / NATUREL / NATURAL

Abete Bianco	0040703	0040702	0040802	0040801	0040807
Frassino	0040714	0040713	0040817	0040816	0040822
Mogano	0040747	0040746	0040862	0040861	0040867
Multicolor	0040758	0040757	0040877	0040876	0040882
Selva	0040736	0040735	0040847	0040846	0040852
Ulivo	0040725	0040724	0040832	0040831	0040837

GRIP

GRIP / GRIP OBERFLÄCHE / GRIP / ANTIDESLIZANTE

Abete Bianco	-	-	0040812	0040811	-
Frassino	-	-	0040827	0040826	-
Mogano	-	-	0040872	0040871	-
Multicolor	-	-	0040887	0040886	-
Selva	-	-	0040857	0040856	-
Ulivo	-	-	0040842	0040841	-



BATTISCOPA

6x80
2^{11/16}"x32"
12 pcs x box



**GRADINO CON TORO
INCOLLATO**

20x60
8"x24"
± 9,5 4pz x box



ELEMENTO L

grip
20x80x5
8"x32"x2"
± 9,5 2pz x box

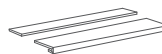

**GRADONE DOPPIA
VELA LINEARE**

35x120x4x2
13^{13/16}"x48"x1^{11/16}"x3^{11/16}"
± 10,5 4pz x box



**GRADONE DOPPIA
VELA ANGOLARE**

SX 35x120x4x2
13^{13/16}"x48"x1^{11/16}"x3^{11/16}"
± 10,5 2pz x box

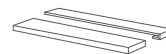

**GRADONE DOPPIA
VELA ANGOLARE**

DX 35x120x4x2
13^{13/16}"x48"x1^{11/16}"x3^{11/16}"
± 10,5 2pz x box

Abete Bianco	0040804	0040803	0040813	0040704	0040706	0040705
Frassino	0040819	0040818	0040828	0040715	0040717	0040716
Mogano	0040864	0040863	0040873	0040748	0040450	0040749
Multicolor	0040879	0040878	0040888	0040759	0040761	0040760
Selva	0040849	0040848	0040858	0040737	0040739	0040738
Ulivo	0040834	0040833	0040843	0040726	0040728	0040727

natura

Gres porcellanato colorato in massa

Colorbody porcelain stoneware / Durhgefärbtes Steinzeug / Grès cérame coloré dans le masse / Gres porcelánico coloreado en toda la masa

UNI EN 14411 G Bia



0040806
Composition ECO
Abete Bianco
20x80_8"x32" 3 pz.

1 cmp x box



0040821
Composition ECO
Frassino
20x80_8"x32" 3 pz.

1 cmp x box

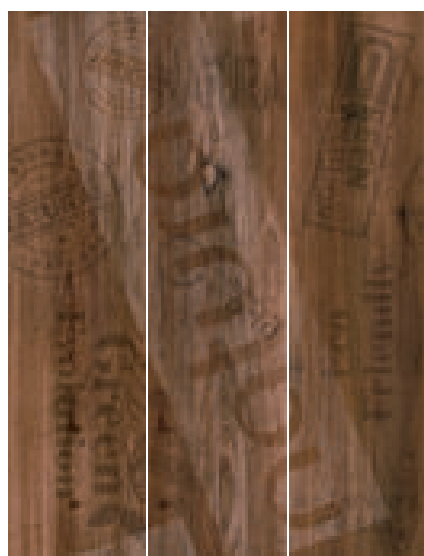

0040866
Composition ECO
Mogano
20x80_8"x32" 3 pz.

1 cmp x box



0040881
Composition ECO
Multicolor
20x80_8"x32" 3 pz.

1 cmp x box



0040851
Composition ECO
Selva
20x80_8"x32" 3 pz.

1 cmp x box



0040836
Composition ECO
Ulivo
20x80_8"x32" 3 pz.

1 cmp x box



PENDULUM TEST BS 7976
Grip > 36 dry / > 36 wet



ASTM C 1028
Nat > 0,60 dry / > 0,60 wet
Grip > 0,60 dry / > 0,60 wet



BOT 3000
ANSI A 137.1:2012
DCOF ≥ 0.42



0040805
Mosaico Bianco
30x30 - 12"x12"
4 pcs x box

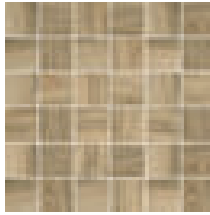

0040820
Mosaico Frassino
30x30 - 12"x12"
4 pcs x box

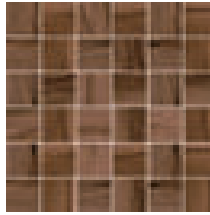

0040865
Mosaico Mogano
30x30 - 12"x12"
4 pcs x box



0040880
Mosaico Multicolor
30x30 - 12"x12"
4 pcs x box

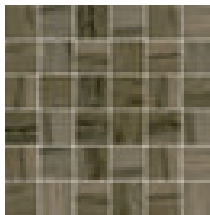

0040850
Mosaico Selva
30x30 - 12"x12"
4 pcs x box

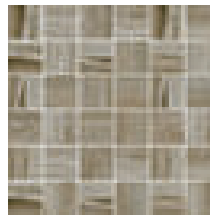

0040835
Mosaico Ulivo
30x30 - 12"x12"
4 pcs x box

Avvertenze per la posa: si consiglia la posa a corriere del materiale, sfalsando il lato più lungo per massimo 30 cm sulla lunghezza del pezzo adiacente. Utilizzare una fuga di minimo 2 mm.

Attention when laying: we recommend laying in a brick pattern, staggering the slats so that the longer side is offset a maximum of 30 cm against its neighbour. Leave a minimum 2 mm gap between slats.

Hinweise für die Verlegung: Es wird die fortlaufende Verlegung des Materials empfohlen, mit Versetzung der Längsseite um maximal 30 cm zum anliegenden Teil. Eine Fuge von mindestens 2 mm vorsehen.

Avertissement pour la pose : une pose à l'anglaise du matériau est conseillée, en décalant le côté le plus long de 30 cm maximum sur la longueur de l'élément adjacent. Utiliser un joint d'au moins 2 mm.

Advertencia para la colocación: aconsejamos la colocación del material a junta partida, escalonando el lado más largo como máximo 30 cm. sobre la longitud de la pieza contigua. Utilícese una junta de 2 mm. como mínimo.

Imballi / Packing / Verpackungen / Emballages / Embalajes

Formato Size Größe Format Tamaño	Pezzi/Sc. Pcs/Box Pcs/Ctn Stck/Kart Piezas/Caja	Mq/Sc Sq.M/Box Mq/Ctn Qm/Kart Mq/Caja	Sc/Pal Box/Pal Ctn/Pal Kart/Pal Caja/Pal	Mq/Pal Sq.M/Pal Mq/Pal Qm/Pal Mq/Pal	Kg/Sc Kg/Box Kg/Ctn Kg/Kart Kg/Caja	Kg/Pal Kg/Pal Kg/Pal Kg/Pal Kg/Pal
20x120	5	1,20	27	32,4	28,00	756
15x120	6	1,08	28	30,24	25,50	714
20x80	8	1,28	48	61,44	28,00	1344
13x80	12	1,25	54	67,50	27,50	1485
2x20x80 Composition A+B	4	0,64	-	-	14,00	-



neostone

Gres porcellanato colorato in massa

Colorbody porcelain stoneware / Durghgefärbtes Steinzeug / Grès cérame coloré dans le masse / Gres porcelánico coloreado en toda la masa

UNI EN 14411 G BIa



Mosaico 3D Grigio 16,5x50
Grigio Nat. 50x100
Grigio Grip 50x100 / 50x50 / 50x33,3 / 33,3x33,3



Formati / Sizes / Grösse / Format / Tamaño:



50x100
20"x40"



50x50
20"x20"



33,3x50
13"x20"



33,3x33,3
13"x13"

Superfici / Surface / Oberfläche / Surface / Superficie



NATURALE / NATURAL / NATUR / NATUREL / NATURAL

GRIP / GRIP / GRIP OBERFLÄCHE / GRIP / ANTIDESLIZANTE

neostone

Gres porcellanato colorato in massa

Colorbody porcelain stoneware / Durghgefärbtes Steinzeug / Grès cérame coloré dans le masse / Gres porcelánico coloreado en toda la masa

UNI EN 14411 G B1a

Avorio

Grigio

Antracite



NATURALE
NATURAL / NATUR / NATUREL / NATURAL

GRIP
GRIP / GRIP OBERFLÄCHE / GRIP / ANTIDESLIZANTE



PENDULUM TEST BS 7976
Grip > 36 dry / da 25 a 35 wet



BOT 3000
ANSI A 137.1:2012
DCOF ≥ 0,42



0025408 Mosaico 3D Avorio
16,5x50 - 6¼"x20"
2 pcs x box

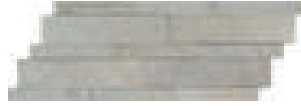

0025428 Mosaico 3D Grigio
16,5x50 - 6¼"x20"
2 pcs x box



0025448 Mosaico 3D Antracite
16,5x50 - 6¼"x20"
2 pcs x box



0025409 Mosaico Avorio
33,3x33,3 - 13"x13"
4 pcs x box



0025429 Mosaico Grigio
33,3x33,3 - 13"x13"
4 pcs x box



0025449 Mosaico Antracite
33,3x33,3 - 13"x13"
4 pcs x box



50x100
20"x40"



50x50
20"x20"



33,3x50
13"x20"



33,3x33,3
13"x13"



BATTISCOPA
9,5x50
3^{7/8}"x20"
20 pcs x box



TORO
5x33,3
2"x13"
4 pcs x box



TORO ANG.
5x33,3
2"x13"
2 pcs x box

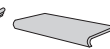

ELEMENTO ad L
16,5x30x4,5
6^{3/4}"x12"x1^{7/8}"
8 pcs x box

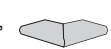

GRADONE ANG.
16,5x30x4,5
6^{3/4}"x12"x1^{7/8}"
4 pcs x box

NATURALE

NATURAL / NATUR / NATUREL / NATURAL

Avorio	0025400	0025402	0025404	0025406	0025410	0025411	0025412	-	-
Grigio	0025420	0025422	0025424	0025426	0025430	0025431	0025432	-	-
Antracite	0025440	0025442	0025444	0025446	0025450	0025451	0025452	-	-

GRIP

GRIP / GRIP OBERFLÄCHE / GRIP / ANTIDESLIZANTE

Avorio	0025401	0025403	0025405	0025407	-	-	-	0025413	0025414
Grigio	0025421	0025423	0025425	0025427	-	-	-	0025433	0025434
Antracite	0025441	0025443	0025445	0025447	-	-	-	0025453	0025454

Imballi / Packing / Verpackungen / Embalajes

Formato	Pezzi/Sc.	Mq/Sc	Sc/Pal	Mq/Pal	Kg/Sc	Kg/Pal
Size	Pcs/Box	Sq.M/Box	Box/Pal	Sq.M/Pal	Kg/Box	Kg/Pal
Größe	Pcs/Ctn	Mq/Ctn	Ctn/Pal	Mq/Pal	Kg/Ctn	Kg/Pal
Format	Stck/Kart	Qm/Kart	Kart/Pal	Qm/Pal	Kg/Kart	Kg/Pal
Tamaño	Piezas/Caja	Mq/Caja	Caja/Pal	Mq/Pal	Kg/Caja	Kg/Pal
50x100	3	1,50	30	45,00	37,30	1119,00
50x50	6	1,50	24	36,00	34,16	819,84
33,3x50	6	1,00	48	48,00	24,00	1152,00
33,3x33,3	10	1,11	46	51,06	24,45	1124,70

neostone

Gres porcellanato colorato in massa

Colorbody porcelain stoneware / Durghgefärbtes Steinzeug / Grès cérame coloré dans la masse / Gres porcelánico coloreado en toda la masa

UNI EN 14411 G Bla

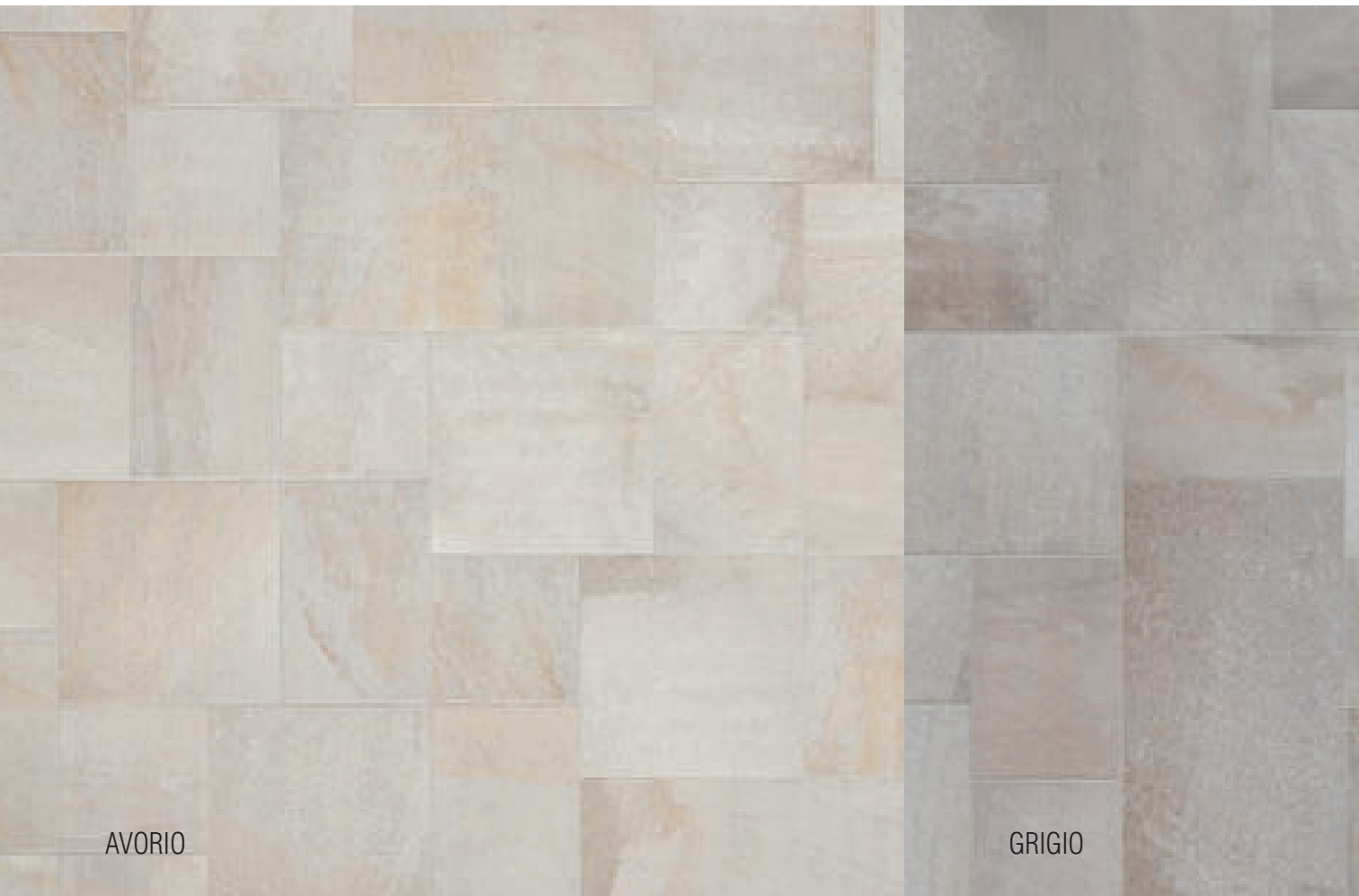

	33,3x33,3 cm	33,3x50 cm	50x50 cm
N° pezzi per modulo N° pieces for module	2	2	2
% mq	21,03%	31,57%	47,40%

	Naturale	Grip
Avorio	NEN 3A AV	NEG 3A AV
Grigio	NEN 3A GR	NEG 3A GR
Antracite	NEN 3A AN	NEG 3A AN

Modulo 3A

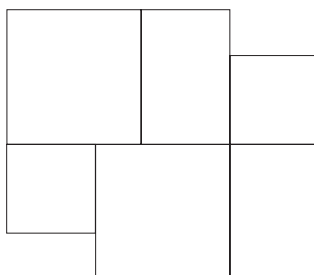

	33,3x33,3 cm	33,3x50 cm	50x50 cm	50x100 cm
N° pezzi per modulo N° pieces for module	1	2	1	1
% mq	9,29%	27,88%	20,94%	41,88%

	Naturale	Grip
Avorio	NEN 4A AV	NEG 4A AV
Grigio	NEN 4A GR	NEG 4A GR
Antracite	NEN 4A AN	NEG 4A AN

Si raccomanda la posa con fuga 4 mm / Laying with joints of 4 mm is strongly recommended / Es wird die Verlegung mit einer Fugenbreite von 4 mm empfohlen / Pose avec joint de 4 mm recommandée / En el solado se aconseja dejar juntas de 4 mm



ANTRACITE

Modulo 4A

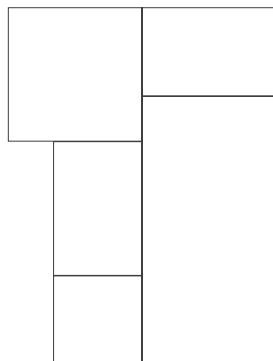

	33,3x33,3 cm	33,3x50 cm	50x50 cm
N° pezzi per modulo N° pieces for module	3	2	1
% mq	36,33%	36,37%	27,30%

	Naturale	Grip
Avorio	NEN 3B AV	NEG 3B AV
Grigio	NEN 3B GR	NEG 3B GR
Antracite	NEN 3B AN	NEG 3B AN

Modulo 3B

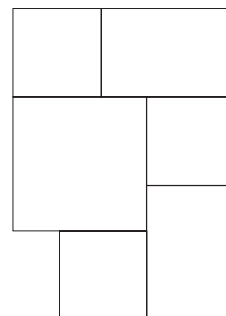

steam wood

Gres porcellanato colorato in massa

Colorbody porcelain stoneware / Durghgefärbtes Steinzeug / Grès cérame coloré dans le masse / Gres porcelánico coloreado en toda la masa

UNI EN 14411 G B1a



Dove Gray To Nat 15x120 - 20x120



Formati / Sizes / Grösse / Format / Tamaño:

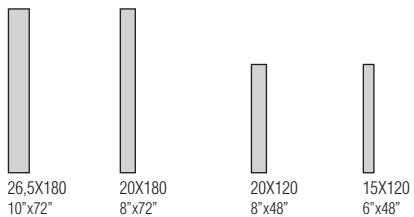

Superfici / Surface / Oberfläche / Surface / Superficie



steam wood

Gres porcellanato colorato in massa

Colorbody porcelain stoneware / Durghgefärbtes Steinzeug / Grès cérame coloré dans le masse / Gres porcelánico coloreado en toda la masa

UNI EN 14411 G B1a



Charcoal An 20x180_8"x72" / gradone doppia vela lineare



Ash Gr 26,5x180_10"x72"

steam wood

Gres porcellanato colorato in massa

Colorbody porcelain stoneware / Durghgefärbtes Steinzeug / Grès cérame coloré dans le masse / Gres porcelánico coloreado en toda la masa

UNI EN 14411 G Bla

Pearl White BI

Blonde Ale ST

Dove Gray TO

Ash GR

Charcoal AN

Reddish Brown PR

NATURALE
NATURAL / NATUR / NATUREL / NATURAL



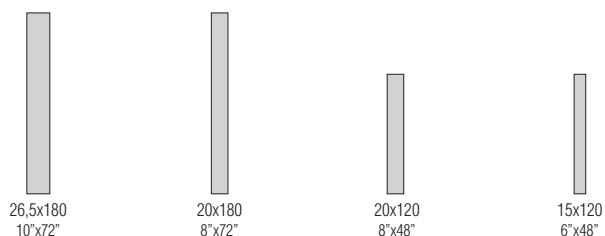

NATURALE

NATURAL / NATUR / NATUREL / NATURAL

Pearl White BI	0058002	0058001	0058032	0058031
Blonde Ale ST	0058007	0058006	0058042	0058041
Dove Gray TO	0058012	0058011	0058052	0058051
Reddish Brown PR	0058017	0058016	0058062	0058061
Ash GR	0058022	0058021	0058072	0058071
Charcoal AN	0058027	0058026	0058082	0058081



Pearl White BI 20x120_8"x48" / 15x120_6"x48" / Charcoal An Listone 3D

steam wood

Gres porcellanato colorato in massa

Colorbody porcelain stoneware / Durghgefärbtes Steinzeug / Grès cérame coloré dans le masse / Gres porcelánico coloreado en toda la masa

UNI EN 14411 G Bia



0058033
Mosaico 5x5
Pearl White BI
30x30 - 12"x12"
4 pcs x box



0058043
Mosaico 5x5
Blonde Ale ST
30x30 - 12"x12"
4 pcs x box

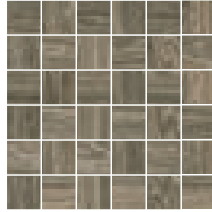

0058053
Mosaico 5x5
Dove Gray TO
30x30 - 12"x12"
4 pcs x box

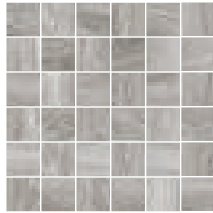

0058073
Mosaico 5x5
Ash GR
30x30 - 12"x12"
4 pcs x box



0058083
Mosaico 5x5
Charcoal AN
30x30 - 12"x12"
4 pcs x box



0058063
Mosaico 5x5
Reddish Brown PR
30x30 - 12"x12"
4 pcs x box



0058035
Listone 3D Pearl White BI
18x120 - 7¹/₁₆"x48"
2 pcs x box

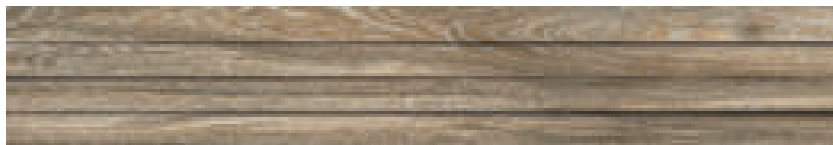

0058045
Listone 3D Blonde Ale ST
18x120 - 7¹/₁₆"x48"
2 pcs x box



0058055
Listone 3D Dove Gray TO
18x120 - 7¹/₁₆"x48"
2 pcs x box



0058075
Listone 3D Ash GR
18x120 - 7¹/₁₆"x48"
2 pcs x box



0058085
Listone 3D Charcoal AN
18x120 - 7¹/₁₆"x48"
2 pcs x box



0058065
Listone 3D Reddish Brown PR
18x120 - 7¹/₁₆"x48"
2 pcs x box



ASTM C 1028
Nat > 0,60 dry / > 0,60 wet



BOT 3000
ANSI A 137.1:2012
DCOF ≥ 0,42

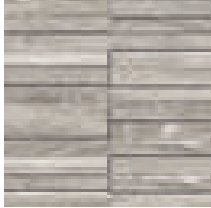

0058034
Mosaico 3D
Pearl White BI
28,5x28,5 - 12"x12"
4 pcs x box



0058044
Mosaico 3D
Blonde Ale ST
28,5x28,5 - 12"x12"
4 pcs x box



0058054
Mosaico 3D
Dove Gray TO
28,5x28,5 - 12"x12"
4 pcs x box



0058074
Mosaico 3D
Ash GR
28,5x28,5 - 12"x12"
4 pcs x box



0058084
Mosaico 3D
Charcoal AN
28,5x28,5 - 12"x12"
4 pcs x box

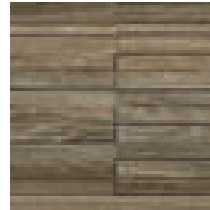

0058064
Mosaico 3D
Reddish Brown PR
28,5x28,5 - 12"x12"
4 pcs x box

Avvertenze per la posa: si consiglia la posa a correrre del materiale, sfalsando il lato più lungo per massimo 30 cm sulla lunghezza del pezzo adiacente. Utilizzare una fuga di minimo 2 mm.

Attention when laying: we recommend laying in a brick pattern, staggering the slats so that the longer side is offset a maximum of 30 cm against its neighbour. Leave a minimum 2 mm gap between slats.

Hinweise für die Verlegung: Es wird die fortlaufende Verlegung des Materials empfohlen, mit Versetzung der Längsseite um maximal 30 cm zum anliegenden Teil. Eine Fuge von mindestens 2 mm vorsehen.

Avertissement pour la pose : une pose à l'anglaise du matériau est conseillée, en décalant le côté le plus long de 30 cm maximum sur la longueur de l'élément adjacent. Utiliser un joint d'au moins 2 mm.

Advertencia para la colocación: aconsejamos la colocación del material a junta partida, escalonando el lado más largo como máximo 30 cm. sobre la longitud de la pieza contigua. Utilícese una junta de 2 mm. como mínimo.



BATTISCOPA 7x120
2^{3/4}"x48"
8 pcs x box



GRADONE DOPPIA VELA LINEARE
35x120x4x2
13^{3/16}"x48"¹x120"²x13^{3/16}"
4 cmp x box

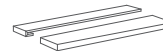

GRADONE DOPPIA VELA ANGOLARE SX
35x120x4x2
13^{3/16}"x48"¹x120"²x13^{3/16}"
2 cmp x box



GRADONE DOPPIA VELA ANGOLARE DX
35x120x4x2
13^{3/16}"x48"¹x120"²x13^{3/16}"
2 cmp x box

NATURALE

NATURAL / NATUR / NATUREL / NATURAL

	0058036	0058037	0058039	0058038
Pearl White BI				
Blonde Ale ST	0058046	0058047	0058049	0058048
Dove Gray TO	0058056	0058057	0058059	0058058
Reddish Brown PR	0058066	0058067	0058069	0058068
Ash GR	0058076	0058077	0058079	0058078
Charcoal AN	0058086	0058087	0058089	0058088

Imballi / Packing / Verpackungen / Embalajes / Embalajes

Formato	Pezzi/Sc.	Mq/Sc	Sc/Pal	Mq/Pal	Kg/Sc	Kg/Pal
Size	Pcs/Box	Sq.M/Box	Box/Pal	Sq.M/Pal	Kg/Box	Kg/Pal
Grösse	Pcs/Ctn	Mq/Ctn	Ctn/Pal	Mq/Pal	Kg/Ctn	Kg/Pal
Format	Stok/Kart	Om/Kart	Kart/Pal	Om/Pal	Kg/Kart	Kg/Pal
Tamaño	Piezas/Caja	Mq/Caja	Caja/Pal	Mq/Pal	Kg/Caja	Kg/Pal
26,5x180	3	1,44	36	51,84	34,00	1224,00
20x180	4	1,44	40	57,60	34,00	1360,00
20x120	5	1,20	27	32,40	28,00	756,00
15x120	6	1,08	28	30,24	25,50	714,00



TECH-INFO



CERTIFICAZIONI

CERTIFICATIONS / ZERTIFIZIERUNGEN / CERTIFICATIONS / CERTIFICACIONES

SIMBOLOGIA

KEY TO SYMBOLS / SYMBOLE / SYMBOLOGIE / SIMBOLOGÍA



PAVIMENTO
FLOOR TILES
REVÊTEMENT
BODENFLIESEN
PAVIMENTO



RIVESTIMENTO
WALL TILES
REVÊTEMENT
WANDVERKLEIDUNG
REVESTIMIENTO



GRES PORCELLANATO TUTTA MASSA
FULL BODY PORCELAIN STONEWARE
GRES PORCELAIN PLEINE MASSE
FEINSTEINZEUG IN DER MASSE GEFÄRBT
GRES PORCELÁNICO EN TODA SU MASA



SCHLÜSSTÄ
SLIP FACTOR
GLISSANCE
RUTSCHFESTIGKEIT
RESBALAMIENTO



SPESSORE
THICKNESS
ÉPAISSEUR
DICKE
ESPESOR



INGELIVO
FROST PROOF
INGELFEE
FROSTSICHER
RESISTENTE AL HIELO



RESISTENZA ALL'ABRASIONE
RESISTANCE TO ABRASION
OBERFLÄCHENABRIEBFESTIGKEIT
RÉSISTANCE À L'ABRASION
RESISTENCIA A LA ABRASIÓN



ASPETTO UNIFORME
UNIFORM APPEARANCE
ASPECT UNIFORME
GLEICHARTIGES AUSSEHEN
ASPECTO UNIFORME



LIEVE VARIAZIONE
SLIGHT VARIATION
LEGERE VARIATION
LEICHTE SCHÄTTIERUNG
LEVE VARIACION



MODERATA VARIAZIONE
MODERATE VARIATION
VARIATION MODÉRÉE
MAÄSSIGE SCHÄTTIERUNG
MODERADA VARIACION



FORTE STONALIZZAZIONE
SUBSTANTIAL VARIATION
EFFET DENUANCE TRÈS ACCENTUÉE
STARKE SCHÄTTIERUNG
FUERTE DESTONIFICADO



Un metodo semplice e significativo per definire il grado di compatibilità fra pavimento e destinazione d'uso, cioè fra pavimento e caratteristiche ambientali, è il "Classement UPEC", metodo francese costituito da una classificazione dei locali/edifici in relazione alla severità delle condizioni d'impiego e ai conseguenti livelli di prestazione richiesti alla pavimentazione, indicato dalle lettere:

U = grado di resistenza all'usura e all'abrasione (indici da 1 a 4 con numero crescente in relazione alla maggiore resistenza).

P = grado di resistenza meccanica (indici da 1 a 4 con numero crescente in relazione alla maggiore resistenza).

E = comportamento dell'acqua (indici da 0 a 3 con numero crescente in relazione al miglior comportamento).

C = comportamento ai prodotti chimici e alle macchie (indici da 0 a 3 con numero crescente in relazione alla maggiore resistenza ad acidi, basi e prodotti macchianti).

A simple and significant method to define the grade of compatibility between the floor and the settled function, that is between the floor and the environmental features, is the "Classement UPEC", french method constituted by the rating of the premises in relation to the severity of the application terms and to the consequent levels of performance required by the flooring. The rating uses the following letters:

U = grade of wear and abrasion resistance (indexes from 1 to 4 with number increasing in relation to greater resistance).

P = grade of mechanical resistance (indexes from 1 to 4 with number increasing in relation to greater resistance).

E = water absorption (indexes from 0 to 3 with number increasing in relation to better absorption).

C = resistance to chemical products and staining (indexes from 0 to 3 with number increasing in relation to greater resistance to acids, alkalis and staining products).

Eine einfache und bedeutende Methode zur Bestimmung der Verträglichkeitsstufe zwischen Boden und eingesetzter Funktion bzw Boden und Umweltbedingungen ist "UPEC Klassifizierung": es geht um eine französische Methode, die aus einer Einstufung der Lokale und Gebäude nach den Gebrauchskonditionen und den folgenden vom Boden erforderten Leistungsniveau wie folgt besteht:

U = Abrieb und Abschlagsgruppe (Indexziffer von 1 bis 4 mit größerer Nummer nach größerer Wiederständigkeit).

P = Mechanische Beständigkeit (Indexziffer von 1 bis 4 mit größerer Nummer nach größerer Wiederständigkeit).

E = Wasserverhalten (Indexziffer von 0 bis 3 mit größerer Nummer nach besserem Verhalten).

C = Beständigkeit auf chemische Produkte und Flecke (Indexziffer von 0 bis 3 mit größerer Nummer nach größerer Beständigkeit auf Säure-Base und befleckte Produkte).

Une simple et significative méthode pour établir le degré de compatibilité entre sol et fonction installée, c'est-à-dire entre sol et caractéristiques du milieu ambiant est le "Classement UPEC", méthode française représentée par une classification des locaux et des établissements par rapport à la sévérité des conditions d'emploi et aux conséquents niveaux de performances nécessaires au pavage, comme suit:

U = Degré de résistance à l'usure et à l'abrasion (indices de 1 à 4 avec numero croissant par rapport à la résistance majeure).

P = Degré de résistance mécanique (indices de 1 à 4 avec numero croissant par rapport à la résistance majeure).

E = Comportement de l'eau (indices de 0 à 3 avec numero croissant par rapport au meilleur comportement).

C = Réaction aux produits chimiques et aux taches (indices de 0 à 3 avec numero croissant par rapport à la résistance majeure aux acides, bases et produits tachants).

Un método simple y significativo para definir el grado de compatibilidad entre suelo y función establecida, es decir, entre suelo y características ambientales, es el "Classement UPEC", método francés basado en una clasificación de los locales de lo edificios según la severidad de las condiciones de empleo y los consecuentes niveles de prestación requeridos parwdicados por las letras:

U = grado de resistencia al desgaste y a la abrasión (índice de 1 a 4 con número creciente con relación a la mayor resistencia).

P = grado de resistencia mecánica (índice de 1 a 4 con número creciente con relación a la mayor resistencia).

E = comportamiento del agua (índice de 0 a 3 con número creciente con relación al mejor comportamiento).

C = resistencia a los productos químicos y a las manchas (índice de 0 a 3 con número creciente con relación a la mayor resistencia a ácidos, bases y productos que pueden manchar).



L'Azienda assolve agli obblighi sulla marcatura CE. / The Company fulfils its CE marking obligations. Die Firma erfüllt die Verpflichtungen für das CE-Kennzeichnung. / Conformément aux dispositions en matière de marquage CE. / La empresa cumple con las obligaciones del sello CE.

LE NORME EN 14411 / EN 14411 STANDARDS / NORMES EN 14411 / EN 14411 NORMEN / NORMAS EN 14411

CLASSIFICAZIONE DELLE PIASTRELLE SECONDO GRUPPO DI APPARTENENZA E NORMA DI PRODOTTO / CLASSIFICATION OF CERAMIC TILES ACCORDING TO SPECIFIC GROUP AND RELATED NORM / CLASSIFICATION DES CARREAUX CERAMIQUES EN FONCTION DU GROUPE D'APPARTENANCE ET NORME DE PRODUIT / KLASSIFIZIERUNG DER KERAMIK FLIESEN NACH ZUGEHÖRIGKEITS-GRUPPE UND PRODUKTNORME / CLASIFICACIÓN DE LAS BALDOSAS SEGÚN GRUPO DE PERTENENCIA Y NORMA DE PRODUCTO

Gruppo B Ia Group B Ia Grupe B Ia Gruppe B Ia Grupo B Ia (Standard EN 14411 Annex G)	$E \leq 0,5\%$
Gruppo B Ib Group B Ib Grupe B Ib Gruppe B Ib Grupo B Ib (Standard EN 14411 Annex H)	$0,5 < E \leq 3\%$
Gruppo B IIa Group B IIa Grupe B IIa Gruppe B IIa Grupo B IIa (Standard EN 14411 Annex J)	$3 < E \leq 6\%$
Gruppo B IIb Group B IIb Grupe B IIb Gruppe B IIb Grupo B IIb (Standard EN 14411 Annex K)	$6 < E \leq 10\%$
Gruppo B III Group B III Grupe B III Gruppe B III Grupo B III (Standard EN 14411 Annex L)	$E > 10\%$

ASSORBIMENTO D'ACQUA

WATER ABSORPTION / ABSORPTION D'EAU / WASSERABSORPTION / ABSORCIÓN DE AGUA



ASTM International è il più grande ente di normazione al mondo su base volontaria, ed è riconosciuto come fonte affidabile di norme tecniche su materiali, prodotti, sistemi e servizi. Note per la loro alta qualità tecnica ed attinenza al mercato, le norme ASTM rivestono un ruolo di primaria importanza all'interno della infrastruttura informativa che guida le attività di progettazione, costruzione e commerciali su scala mondiale.

ASTM International is the world's largest voluntary standards organisation, and is respected as a reliable source of technical standards on materials, products, systems and services. Known for their high technical quality and market-relevance, ASTM standards play a role of primary importance within the IT infrastructures that provide guidance for design, construction and commercial activities worldwide.

Die ASTM International ist die größte Standardisierungsorganisation weltweit. Die Verwendung ihrer Standards ist freiwillig. Sie gilt als zuverlässige Quelle von technischen Normen für Materialien, Produkte, Systeme und Dienstleistungen. Die ASTM-Standards, bekannt wegen ihrer hohen technischen Qualität und Marktbezogenheit, spielen in der Informationsinfrastruktur, die den Entwicklungs-, Herstellungs- und Vertriebstätigkeiten in der ganzen Welt zugrunde liegt, eine erstrangige Rolle.

Le piastrelle di ceramica sono suddivise in gruppi secondo il loro metodo di formatura (estruse o pressate a secco) ed il loro assorbimento d'acqua. Le piastrelle formate a partire da materie prime ridotte in polvere o piccoli grani e forgiate in stampi a pressione elevata, appartengono al gruppo "B". Queste possono essere smaltate o non smaltate. Le piastrelle sono suddivise inoltre in gruppi di assorbimento d'acqua. Le norme di prodotto definiscono per ogni gruppo: Le dimensioni e la qualità della superficie, le proprietà fisiche, le proprietà chimiche, la marcatura e la designazione delle piastrelle e degli imballaggi.

Ceramic tile types are subdivided into groups in accordance with the method of forming used in their production and in accordance with their water absorption values. High pressed tile manufactured from powder or granulate material belong to the "B" group. Like extruded tiles, pressed tile may be either glazed or unglazed. Apart from the above groupings, ceramic tile sub-divide into different water absorption categories. The above product norms also give the dimensional tolerances required for each grouping and sub-grouping, and determine the mechanical, physical and chemical characteristics and specifications together with the appearance of the ceramic tiles.

Die Keramikfliesen werden je nach der zu ihrer Formung verwendeten Methode und ihrer Wasserabsorption in Gruppen unterteilt. Mit dem Buchstaben B werden diejenigen Fliesen bezeichnet, die aus in Pulver oder Körnchenform vorliegenden Rohstoffen hergestellt und unter hohem Druck in Pressformen geformt werden. Sie können glasiert oder nicht glasiert sein. Weiterhin werden Fliesen in Gruppen nach Wasserabsorption unterteilt: Die Produktnormen legen für jede Gruppe Maßbezugsgröße, Maßabweichungen, mechanische, physikalische und chemische Eigenschaften sowie Aussehen und Bezeichnung fest.

Les carreaux de céramique se distinguent selon leur type de moulage et de leur absorption d'eau. La lettre B est donnée aux carreaux formés à partir de matières premières broyées ou préalable pour obtenir des poudres ou des petits granules et moulées ensuite dans des moules à pression élevée. Ils peuvent être émaillés ou non. Les carreaux se distinguent également selon leur absorption d'eau: Les normes de produit fixent pour chaque groupe les dimensions, les tolérances dimensionnelles, les caractéristiques mécaniques, physiques et chimiques, l'aspect et la désignation de carreaux céramiques.

Las baldosas de cerámica se reparten en grupos, según su método de prensado y su grado de absorción de agua. Las baldosas formadas a partir de materias primas reducidas en polvo o en granos pequeños y formadas en moldes bajo presión elevada pertenecen al grupo B. Estas pueden ser esmaltadas y no esmaltadas. Las baldosas se reparten, además, en grupos según el grado de absorción de agua: Las normas de producto definen, para cada grupo, las dimensiones, las tolerancias de dimensión, las características mecánicas, físicas y químicas y la designación de las baldosas cerámicas.

ASTM International est le plus grand organisme d'élaboration de normes volontaires au monde, reconnu comme une source fiable de normes techniques pour les matériaux, produits, systèmes et services. Connues pour leur haute qualité technique et leur pertinence sur le marché, les normes internationales ASTM jouent un rôle majeur dans l'infrastructure d'information qui guide les activités de conception, fabrication et de commerce à l'échelle mondiale.

ASTM International es el mayor organismo mundial de reglamentación voluntaria y cuenta con el reconocimiento general como fuente fiable de emanación de normas técnicas sobre materiales, productos, sistemas y servicios. Conocidas por su alta calidad técnica y su cercanía a la realidad del mercado, las normas ASTM desempeñan una función de importancia primordial dentro de la infraestructura informativa que guía tareas como el diseño de proyectos, la construcción de edificios y las actividades comerciales a escala mundial.

CERTIFICAZIONI

CERTIFICATIONS / ZERTIFIZIERUNGEN / CERTIFICATIONS / CERTIFICACIONES



Cerdisa è membro del Green Building Council Italia, associazione che promuove la cultura dell'edilizia sostenibile energeticamente efficiente, rispettosa dell'ambiente contribuendo a migliorare la qualità della vita dei cittadini attraverso lo standard di certificazione LEED®.

Cerdisa is a member of the Green Building Council Italia, an association that promotes sustainable energy-efficient building practices, which are environmentally friendly and help improve the quality of life through LEED® certification standards.

Cerdisa, die Mitglied des Green Building Council Italien ist, ein Verband, der die Kultur des nachhaltigen und energieeffizienten, umweltverträglichen Bauens fördert, indem zur Lebensqualität der Mitmenschen durch die Zertifizierung nach den LEED®-Standards beigetragen wird.



Cerdisa ha ottenuto la certificazione di qualità Bureau Veritas Certification. Questa certificazione è riconosciuta in tutto il mondo e consiste nell'ispezione e nella verifica dei prodotti, dei progetti e dei sistemi, in riferimento a standard interni, a norme obbligatorie e volontarie a livello nazionale ed internazionale, al fine di fornire un rapporto di conformità. Tutto questo crea un valore aggiunto all'azienda attraverso un supporto nella gestione del rischio, nel controllo della filiera e nell'incremento dei risultati socio-economici.

Cerdisa has received Bureau Veritas Certification quality certification. This certification, recognised all over the world, involves the inspection and auditing of products, designs and systems, in relation to in-house standards and national and international compulsory and voluntary norms, to allow issue of a conformity report. All this creates value-added for the company by assisting it in risk management, control of the supply chain and the improvement of socio-economic results.

Cerdisa erhielt die Qualitätszertifizierung von Bureau Veritas Certification. Diese Zertifizierung ist weltweit anerkannt und besteht in der Inspektion und Prüfung der Produkte, Projekte und Systeme bezüglich der Erfüllung unternehmensinterner Standards sowie nationaler und internationaler obligatorischer und freiwilliger Normen. Aufgrund eines Supports im Risikomanagement, der Lieferantenkontrolle und der Steigerung der sozialen und wirtschaftlichen Resultate handelt es sich für das Unternehmen um eine wertschöpfende Maßnahme.



La certificazione CCC, introdotta nel 2002 interessa sia i prodotti di importazione che quelli di produzione cinese destinati a quel mercato. Le informazioni sulla certificazione CCC riguardano in generale la sicurezza e la salute, con particolare riferimento, nel caso delle piastrelle di ceramica, alle sole piastrelle in gres porcellanato, con un assorbimento minore o uguale allo 0,5%. La certificazione si ottiene attraverso l'intervento di istituti appositamente accreditati dalle autorità cinesi, tutti con sede in Cina.

CCC certification, introduced in 2002, applies to products both imported to China and produced in the country for the Chinese market. Information concerning CCC certification generally relates to health and safety. In the case of ceramic tiles, reference is made specifically only to porcelain tiles having water absorption of 0.5% or less. Certification is obtained through institutions specifically accredited by the Chinese authorities, all based in China.

Die im Jahr 2002 eingeführte CCC-Zertifizierung betrifft sowohl in China importierte als auch in China produzierte Erzeugnisse, die für den chinesischen Markt bestimmt sind. Die Informationen über die CCC-Zertifizierung betreffen im Allgemeinen die Sicherheit und Gesundheit und im Bereich von Keramikfliesen insbesondere die Feinsteinzeugfliesen mit einer Wasseraufnahme kleiner oder gleich 0,5 %. Das Zertifizierungsverfahren erfolgt durch die von den chinesischen Behörden akkreditierten Stellen, die sämtlich ihren Geschäftssitz in China haben.

Cerdisa est une membre du GBC Italia (Green Building Council Italia) qui est une association dont l'objectif est de favoriser et accélérer la diffusion d'une culture du bâtiment durable énergétiquement efficace, respectueuse de l'environnement, en sensibilisant l'opinion publique quant à son impact sur la qualité de la vie des citoyens, à travers du système de certification LEED®.

Cerdisa es miembro del Green Building Council Italia, asociación que promueve la cultura de la construcción sostenible energéticamente eficiente, respetuosa con el medio ambiente, contribuyendo a mejorar la calidad de vida de los ciudadanos a través del estándar de certificación LEED®.

Cerdisa a obtenu la certification de qualité Bureau Veritas Certification. Reconnue dans le monde entier, cette certification consiste à inspecter et à vérifier des produits, des projets et des systèmes par rapport à ses référentiels propres, à des normes obligatoires et volontaires, au niveau national et international, pour délivrer ensuite des rapports de conformité. Un support de la gestion des risques, du contrôle de la filière et de l'accroissement des résultats socio-économiques créent ainsi une valeur ajoutée pour l'entreprise.

Cerdisa cuenta con la certificación de calidad Bureau Veritas Certification. Esta certificación, reconocida en el mundo entero, se obtiene tras someter a rigurosa inspección y control productos, proyectos y sistemas que, para ser declarados conformes, deben atenerse a estándares internos y normas obligatorias y voluntarias tanto de ámbito estatal como internacional. De este modo la empresa se dota de un elemento de soporte en la gestión del riesgo y en el control del conjunto del proceso productivo que le reporta un valor añadido y redunda en el incremento de sus resultados socioeconómicos.

La certification CCC, introduite en 2002, intéresse aussi bien les produits d'importation que ceux de production chinoise destinés à ce marché. Les informations sur la certification CCC concernent en général la sécurité et la santé, avec une référence toute particulière, dans le cas des carreaux en céramique, uniquement aux carreaux en grès cérame, à absorption inférieure ou égale à 0,5%. On l'obtient par l'intermédiaire d'organismes de certification et d'accréditation chinois, tous avec siège en Chine.

La certificación CCC, introducida en 2002, concierne tanto a los productos de importación como a los de producción china destinados a ese mismo mercado. La información acerca de la certificación CCC atañe en general a la seguridad y la salud, con especial referencia, en el caso de las baldosas de cerámica, solamente a las baldosas de gres porcelánico, con una absorción inferior o igual al 0,5%. Se consigue a través de la intervención de instituciones específicamente acreditadas por las autoridades chinas, todas ellas sitas en China.



CERTIFICAZIONE SISTEMA DI QUALITÀ ISO 9001

QUALITY SYSTEM CERTIFICATION ISO 9001
 CERTIFICATION SYSTÈME DE QUALITÉ ISO 9001
 ZERTIFIZIERUNG DES QUALITÄTSSYSTEMS ISO 9001
 CERTIFICACIÓN DEL SISTEMA DE CALIDAD ISO 9001

Il sistema Qualità di Cerdisa, certificato secondo UNI EN ISO 9001, è la norma internazionale che garantisce la qualità del sistema aziendale a tutti i livelli e in tutta la sua organizzazione: a livello progettuale, produttivo, commerciale e distributivo. Per il marchio Cerdisa di "Gruppo Ceramiche Ricchetti SpA", la certificazione è riferibile ai prodotti del presente catalogo realizzati con la tecnologia denominata CERDISASTONE, del gres fine porcellanato.

The Quality System at Cerdisa is certified to UNI EN ISO 9001, the international standard which guarantees quality in company methods at all levels and throughout the entire company structure: regarding design, production, marketing and distribution. Certification of "Gruppo Ceramiche Ricchetti SpAs" Cerdisa brand refers to the products in this catalogue, which are made with CERDISASTONE technology for fine, porcelain stoneware.

Le système Cerdisa de certification UNI EN ISO 9001, est la norme internationale garantissant la qualité d'une entreprise à tous les niveaux de son organisation : étude, production, commercialisation et distribution. Pour la marque Cerdisa du "Gruppo Ceramiche Ricchetti Spa", la certification de référence des produits de ce catalogue, est réalisée suivant la technologie dénommée CERDISASTONE, du grès fin cérame.

Das Qualitätssystem von Cerdisa, das nach UNI EN ISO 9001 zertifiziert worden ist, folgt der internationalen Norm, die die Betriebsqualität auf allen Ebenen und in jeder Hinsicht garantiert: im Verkauf und Vertrieb. Für die Marke Cerdisa der "Gruppo Ceramiche Ricchetti Spa" bezieht sich die Zertifizierung auf die Produkte des vorliegenden Katalogs, die mit der als CERDISASTONE bezeichneten Technik für Feinsteinzeug hergestellt worden sind.

El sistema de calidad Cerdisa, certificado según UNI EN ISO 9001, es la norma internacional que garantiza la calidad del sistema empresarial a todos los niveles y en toda su organización: diseño, producción, comercialización y distribución. Para la marca Cerdisa de "Gruppo Ceramiche Ricchetti Spa" la certificación se refiere a los productos del presente catálogo realizados con la tecnología denominada CERDISASTONE del gres fino porcelánico.



CERTIFICAZIONE DEI SISTEMI DI GESTIONE AMBIENTALE DELLE AZIENDE ISO 14001

CERTIFICATION OF COMPANY ENVIRONMENTAL MANAGEMENT SYSTEM ISO 14001
 CERTIFICATION DES SYSTÈMES DE GESTION ENVIRONNEMENTALE DES ENTREPRISES ISO 14001
 ZERTIFIZIERUNG DER UMWELTMANAGEMENTSYSTEME VON UNTERNEHMEN ISO 14001
 CERTIFICACIÓN DE LOS SISTEMAS DE GESTIÓN AMBIENTAL DE LAS EMPRESAS ISO 14001

Tra gli obiettivi prioritari dell'industria delle piastrelle ceramiche del comprensorio di Sassuolo-Maranello c'è la tutela dell'ambiente attraverso la continua valutazione degli impatti ambientali, al fine di perseguire il miglioramento dei problemi di inquinamento. Gruppo Ceramiche Ricchetti S.p.A. azienda leader nella produzione di piastrelle, ha da sempre fatto propri questi obiettivi ottenendo nel Luglio 2003 la relativa certificazione prevista dalla norma ISO 14001.

One of the top priorities of the ceramic tile industry in the Sassuolo-Maranello district is environmental protection, a goal we pursue through continual environmental impact assessment to reduce pollution problems. As a leading tile manufacturer, Gruppo Ceramiche Ricchetti S.p.A. has always pursued these objectives and in July 2003 obtained certification for the ISO 14001 standard in environmental management systems.

Parmi les objectifs prioritaires de l'industrie des carreaux céramiques de la zone Sassuolo-Maranello figure la sauvegarde de l'environnement. C'est en effet par l'évaluation permanente des impacts environnementaux que ce secteur cherche à réduire les problèmes de pollution. Gruppo Ceramiche Ricchetti S.p.A., chef de file dans la production de carreaux, s'est depuis toujours fixé ces objectifs et a obtenu en juillet 2003 la certification correspondante prévue par la norme ISO 14001.

Zu den wichtigsten Zielen der Keramikfliesen-Industrie des Bezirks Sassuolo-Maranello gehört der Umweltschutz durch die kontinuierliche Bewertung der Umweltauswirkungen, mit dem Zweck der Verbesserung der Umweltverschmutzungsprobleme. Gruppo Ceramiche Ricchetti S.p.A., ein Marktleader in der Produktion von Fliesen, hat sich diese Ziele schon immer zu Eigen gemacht und im Juli 2003 die entsprechende Zertifizierung der Norm ISO 14001 erhalten.

Entre los objetivos primordiales de la industria de baldosas cerámicas del distrito de Sassuolo-Maranello se encuentra la protección del medio ambiente por una evaluación constante del impacto ambiental, a fines de reducir los problemas de la contaminación. Gruppo Ceramiche Ricchetti S.p.A., empresa líder en la producción de baldosas cerámicas, haciendo suyos estos objetivos desde siempre, ha conseguido en julio 2003 la certificación correspondiente prevista por la norma ISO 14001.

CONSIGLI DI POSA

INSTRUCTIONS FOR LAYING / HINWEISE ZUR VERLEGUNG / CONSEILS POUR LA POSE / CONSEJOS PARA LA COLOCACIÓN

POSA TRADIZIONALE CON MALTA CEMENTIZIA

- Spessore della malta di allettamento massimo 5-6 cm.
- Dosaggio del legante 300-350 Kg./mq di cemento Portland 325, per impiego generalizzato, dando la preferenza al cemento pozzolanico per posa esterna.
- Rapporto acqua/cemento max 0,5.
- Spolvero di cemento spessore max 2 mm. equivalente a circa 2,8-3,5 Kg./mq.
- Non si può stuccare il pavimento prima di 24 ore dalla posa in opera, ed è ancor meglio se si lasciano trascorrere due o tre giorni. Durante questo tempo il pavimento deve essere protetto da una eventuale troppo rapida evaporazione, con fogli di plastica oppure in mancanza di questi, con continue bagnature. Anche la stuccatura, se eseguita con malta formata da cemento e sabbia, deve essere bagnata, una volta indurita, per almeno tre giorni.

POSA CON ADESIVI

Da effettuare su caldana precedentemente eseguita e sufficientemente stagionata: in condizioni normali almeno una settimana per ogni cm. di spessore.

- Per impiego dell'adesivo seguire scrupolosamente le modalità d'uso indicate dal produttore. Per pavimentazioni esterne seguire il metodo della doppia spalmatura dell'adesivo (sulla caldana e sul retro della piastrella) oppure usare una spatola senza denti. Quanto detto vale per posa su una struttura con freccia sottocarico inferiore ad 1/400 della luce, per frecce superiori consultare il ns. servizio di assistenza. In ogni caso le piastrelle in CERDISASTONE debbono essere posate fugate e l'ampiezza della fuga deve essere proporzionale al formato: indicativamente min. 2-3 mm.
- È consigliabile eseguire la stuccatura col materiale indicato dal produttore dell'adesivo seguendo le relative istruzioni.
- In previsione dell'impiego di uno stucco colorato, si consiglia di sottoporre una piastrella non posata ad un test di macchiabilità; se la piastrella si macchia esistono tre possibilità:
 1. Rinunciare alla stuccatura colorata, ed impiegare normale malta cementizia;
 2. Trattare con idoneo prodotto le superfici delle piastrelle;
 3. Stuccare mediante l'impiego di una apposita siringa e previa nastratura con carta gommata dei bordi delle piastrelle.La malta di allettamento per la posa tradizionale e la caldana predisposta per la posa con adesivo debbono essere separate dal piano di appoggio mediante uno strato di scorrimento costituito da due fogli sovrapposti di polietilene o materiale similare.
- Per superfici continue di notevoli dimensioni (40 mq. per interni - 20 mq. per esterni), la pavimentazione deve essere provvista di giunti elastici, che devono essere eseguiti come da progetto oppure seguendo le istruzioni della direzione lavori o, in mancanza, del servizio assistenza CERDISA e corrispondenti comunque a non più di 4 m2 di superficie continua per esterni e di 6 m2 per interni. I giunti elastici devono interessare lo spessore delle piastrelle e della malta, nella posa tradizionale e delle piastrelle, dell'adesivo e della caldana nella posa con adesivi. Per eventuali informazioni sulle modalità di esecuzione dei giunti è a disposizione il ns. servizio di assistenza clienti. Si consiglia di posare il CERDISASTONE levigato solamente con adesivi e su superfici perfettamente piane.

TRADITIONAL LAYING WITH CEMENT MORTAR

- Maximum mortar thickness 5-6 cm.
- Add binding agent in the proportion of 300-350 Kg./m³ of Portland 325, cement for general use; pozzolana cement is to be preferred for laying outdoors.
- Water/cement ratio 0,5 max.
- Dusting with cement max thickness 2 mm. equivalent to approximately 2,8-3,5 Kg./m².
- The floor cannot be grouted until at least 24 hours after laying, and it is even better to wait for two or three days. During this period the floor must be protected against excessively fast evaporation with plastic sheeting, or if this is not available by continuous wetting. The grouting, if carried out using a cement and sand mortar, must also be wet for at least three days after setting.

LAYING WITH ADHESIVES

The cement-screed must be prepared well in advance and suitably cured: in normal conditions at least one week for each cm. of thickness.

- Follow the manufacturer's instructions for use of the adhesive in every detail.
- For outdoor laying, use the double application method (spreading adhesive both on the cement-screen and on the back of the tile) or use a smooth-edged spreading tool. This method is acceptable for structures with deflection under load less than 1/400 of span; for higher deflections consult our service organization. In all cases CERDISASTONE tiles must be laid with grout, and the width of the grout must be proportional to the tile size: guideline values are min. 2-3 mm.
- Grout with a material recommended by the adhesive manufacturer, following the relative instructions.
- If a coloured grout is to be used, carry out a stain test on a tile which has not been laid. If the tile stains, there are three possibilities:
 1. Give up the idea of the coloured grout, and use an ordinary cement mortar;
 2. Treat the tile surfaces with a suitable product;
 3. Grout using a special applicator after taping the tile edges with adhesive tape. The cement mortar for conventional laying and the cement-screen prepared for laying with adhesive must be separated from the contact surface by a layer consisting two overlapping sheets of polyethylene or similar.
- For large size continuous surfaces (40 sqm. for indoor settings, 20 sqm. for outdoors) the flooring must include expansion joints, which must be constructed as specified by the architect or following the instructions of the site director. If these instructions are not available, contact the CERDISA service organization. The expansion joints must correspond to not more than 4-5 meters of continuous surface for outdoor installations and 6-8 meters for indoor flooring. The expansion joints must pass through the whole thickness of the tiles and the mortar in conventional laying system, and of the tile, the adhesive and the cement-screen when adhesives are used. Our customer service organization can be contacted for information on the construction of expansion joints.

TRADITIONELLE VERLEGUNG MIT ZEMENTMÖRTEL

- Max Mörtelstärke 5-6 cm.
- Dosierung Bindemittel 300-350 Kg./m³ Portland 325, zur allgemeinen Verwendung, für Aussenbeläge sollte besser Trass-Zement verwendet werden.
- Verhältnis Wasser-Zement max 0,5.
- Streuzement max Stärke 2 mm. entsprechend ca. 2,8-3,5 Kg./m².
- Die Verlegungsarbeiten dürfen erst 24 Stunden nach erfolgter Verlegung durchgeführt werden, besser jedoch erst nach zwei oder drei Tagen. Um eine zu schnelle Austrocknung zu vermeiden, muß der Boden während dieser Zeit mit Plastikfolie abgedeckt oder des öfteren befeuchtet werden. Falls die Verlegung mit Zement-Sandmörtel ausgeführt wird, muß der Boden nach Härtung des Mörtels wenigstens drei Tage lang befeuchtet werden.

VERLEGUNG MIT KLEBMITTELN

Auf einem vorrätigen und ausreichend ausgetrocknetem Unterboden: bei normalen Bedingungen wenigstens eine Woche pro cm. Stärke.

- Bei der Anwendung des Klebmittels müssen die Gebrauchsanweisungen des Herstellers genauestens eingehalten werden;
- Bei der Verlegung von Aussenbelägen muß das Klebmittel entweder doppelt aufgetragen werden (d.h. auf den Unterboden und auf die Fliesenrückseite) oder ein Spachtel ohne Zähne verwendet werden. Hierdurch wird für die Struktur ein Durchbiegungswert erreicht, der entsprechend der verlegten Länge unter 1/400 liegt. Für höhere Werte gibt unsere Kundendienstabteilung die entsprechenden Anweisungen. Auf alle Fälle müssen CERDISASTONE Fliesen mit Fügen verlegt werden. Die Fugenbreite muß auf das gewählte Format abgestimmt werden. Richtwerte: min. 2-3 mm.
- Die Verlegung sollte mit Materialien erfolgen, die vom Hersteller des Klebmittels empfohlen werden. Gebrauchsanweisungen genauestens beachten;
- Sollte farbiges Verlegungsmaterial verwendet werden, ist es ratsam, mit einer unverlegten Fliese einen Flekktest vorzunehmen. Nimmt die Fliese Flecken an, so bestehen drei Möglichkeiten:
 1. Keine gefärbten Materialien sondern normalen Zementmörtel verwenden.
 2. Die Oberfläche der Fliese mit einem entsprechenden Mittel behandeln.
 3. Die Seiten der Fliese mit einem Papier-Klebeband abdecken und das Verlegungsmaterial mit einer Spritze anbringen. Der Zementmörtel für eine traditionelle Verlegung und der für eine Verlegung mit Klebmitteln vorbereitete Unterboden müssen durch eine Schicht von zwei übereinandergelagerten Polyäthylfolien oder einem ähnlichen Material von der Auflagefläche getrennt werden.
- Bei durchgehenden großen Flächen (40 m² für Innenräume, 20 m² für Aussenflächen) muß der Bodenbelag mit elastischen Stößen versehen werden, die entsprechend dem Projekt oder nach den Anweisungen der Bauleitung oder aber, falls kein CERDISA-Service o.ä. vorliegt, wenigstens alle 4-5 m bei Aussenflächen und 6-8 m. innenflächen, ausgeführt werden müssen. Die elastischen Stöße müssen so ausgelegt sein, daß bei der traditionellen Verlegung die Stärke der Fliese und des Mörtels berücksichtigt werden. Bei einer Verlegung mittels Klebmitteln muß die Stärke der Fliese, des Klebmittels und des Unterbodens berücksichtigt werden. Eventuelle Informationen bezüglich der Ausführung dieser Arbeiten können bei unserem Kundendienst eingeholt werden.

POSE TRADITIONELLE AVEC MORTIER DE CIMENT

- Epaisseur maximum du mortier de ciment 5-6 cm.
- Dosage du liant 300-350 Kg./m³ de ciment Portland 325, pour un emploi généralisé, en donnant la préférence au ciment à la pouzzolane pour pose externe.
- Rapport eau/ciment maxi 0,5.
- Poudre de ciment épaisseur maxi 2 mm. équivalent à environ 2,8-3,5 Kg./m².
- Le carrelage ne peut pas être jointoyé avant 24 heures de sa pose; il est même préférable d'attendre deux ou trois jours. Pendant ce temps, le carrelage doit être protégé d'une évaporation éventuelle trop rapide, par des feuilles de plastique ou, à défaut, par des mouillages continus. Le jointement aussi, s'il est effectué avec du coulis formé de ciment et sable, doit être mouillé, une fois qu'il a pris, pendant au moins trois jours.

POSE AVEC ADHESIFS

À effectuer sur la sous-couche isolante suffisamment sèche: dans des conditions normales, au moins une semaine pour chaque cm. d'épaisseur.

- Pour l'emploi de l'adhésif, suivre scrupuleusement les indications données par le producteur.
- Pour des carrelages externes, suivre la méthode du double étalement de l'adhésif (sur la sous couche et derrière le carreau) ou bien utiliser une spatule sans dents. Ceci est valable pour faire une structure avec flèche sous charge inférieure à 1/400 de la lumière: pour des flèches supérieures, consulter notre service après-vente. Dans tous les cas, les carreaux en CERDISASTONE doivent être posés avec joints et l'ampleur du joint doit être proportionnelle au format. A titre indicatif: mini 2-3 mm.
- Il est conseillé d'effectuer le jointolement avec la matière indiquée par le producteur de l'adhésif en suivant les instructions données par ce dernier.
- Si l'on désire employer une matière de jointolement colorée, il est conseillé de soumettre un carreau non posé à un test de maculage; si le carreau reste taché, il y a trois possibilités:
 1. Renoncer au jointolement coloré et utiliser du mortier de ciment normal;
 2. Traiter la surface des carreaux avec un produit approprié;
 3. Mettre des bandes de papier gommé sur les bords des carreaux et ensuite jointoyer avec une seringue spéciale. Le mortier de ciment pour la pose traditionnelle et la sous-couche préparée pour la pose avec adhésif doivent être séparés du plan d'appui par une couche constituée de deux feuilles superposées de polyéthylène ou de matière semblable.
- Pour des surfaces continues de très grandes dimensions (40 m² pour intérieurs, 20 m² pour extérieurs), le carrelage doit avoir des joints élastiques, exécutés selon le projet, ou suivant les instructions de la direction des travaux ou du service après-vente CERDISA et correspondants, de toute façon sans dépasser 4-5 ml. de surface continue pour extérieurs et 6-8 ml. pour intérieurs. Les joints élastiques doivent intéresser l'épaisseur des carreaux dans la pose traditionnelle, et des carreaux, de adhésifs et de la sous-couche dans la pose avec des adhésifs. Pour d'éventuelles informations sur les modalités d'exécution des joints, notre service après-vente est à la disposition des clients.

COLOCACIÓN TRADICIONAL CON MORTERO DE CEMENTO

- Máximo espesor del mortero del lecho: 5-6 cm.
- Dosificación del aglomerante: 300-350 kg./m² de cemento Portland 325, para el empleo general; para la colocación en exteriores, debe preferirse el cemento puzolánico.
- Relación agua/cemento: máx. 0,5
- Espolvoreo de cemento, máximo espesor: 2 mm. equivalente a 2,8-3,5 kg/m², aproximadamente.
- Después de la colocación, es preciso esperar por lo menos 24 horas (mejor aún si transcurren 2 ó 3 días) antes de estucar el pavimento. Durante este lapso de tiempo debe protegerse el pavimento contra una posible evaporación demasiado rápida, poniendo hojas de plástico o bien mojàndolo de vez en cuando. También el estucado, si se ha hecho con mortero de cemento y arena, una vez endurecido debe mojar durante 3 días, por lo menos.

COLOCACIÓN CON PEGAMENTO SINTÉTICO

Debe hacerse sobre una capa de base hecha anteriormente y suficientemente desecada (en condiciones normales, por lo menos una semana de desecación por cada centímetro de espesor).

- Respecto al uso del pegamento, atégase escrupulosamente a las instrucciones dadas por el productor.
- Para pavimentaciones exteriores, siga el método del doble untado del pegamento (sobre la capa-base y sobre la parte trasera de la baldosa), o bien utilice una espátula sin dientes. Lo anterior vale para colocación sobre una estructura con flecha bajo carga inferior a 1-400 de la luz; para flechas superiores, consulte nuestro servicio de asistencia. En todo caso, las baldosas en CERDISASTONE deben colocarse con una distancia de separación entre cada dos, la cual ha de ser proporcional al formato.
De manera indicativa, puede ser la siguiente: 2-3 mm.
- Se aconseja usar para el estucado el material indicado por el productor del pegamento, ateniéndose a las instrucciones del mismo.
- En el caso de que se quiera utilizar un estuque de color, es oportuno hacer una prueba con una baldosa suelta, para comprobar si se mancha; en el caso de que se manche, hay tres soluciones posibles:
 1. renunciar al estucado en color y utilizar mortero de cemento normal;
 2. tratar la superficie de las baldosas con un producto idóneo;
 3. cubrir el borde de las baldosas con una cinta engomada y luego estucar utilizando una jeringa.

El mortero que constituye el lecho para colocar las baldosas con el sistema tradicional, o la capa-base preparada para la aplicación con pegamento deben separarse respecto a la superficie de apoyo mediante un estrato de deslizamiento, constituido por dos láminas superpuestas de polietileno u otro material similar.

- Para superficies continuas de dimensiones notables (40 m² para interiores, 20 m² para exteriores), hace falta dotar la pavimentación con juntas elásticas, las cuales deben hacerse conforme al proyecto o bien siguiendo las instrucciones de la Dirección de las Obras o del servicio de asistencia CERDISA; en todo caso, tales juntas deben dejar no más de 4 m² de superficie continua en las pavimentaciones exteriores y 6 m² en el interior. En el caso de colocación tradicional, con mortero, las juntas elásticas tienen que comprender el espesor de las baldosas y del mortero; cuando se colocan con pegamento, hay que considerar el espesor de las baldosas, del pegamento y de la capa-base. Para recibir más información sobre la forma de realización de las juntas elásticas, diríjase a nuestro servicio de asistencia a la clientela. Se aconseja colocar el CERDISASTONE pulido solamente con pegamento y sobre superficie perfectamente planas.

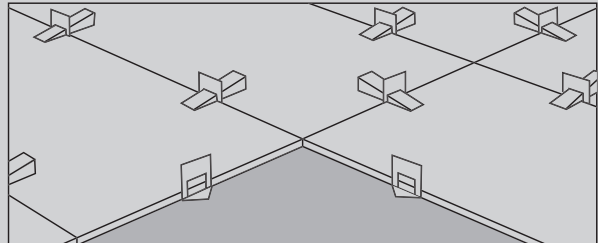

PER ELIMINARE I POSSIBILI DISLIVELLI CHE POSSONO VERIFICARSI POSANDO LASTRE DI GRANDE FORMATO, SI CONSIGLIA VIVAMENTE L'UTILIZZO DI Distanziatori livellanti IN MODO DA OTTENERE OTTENERE CON FACILITÀ E PRECISIONE UNA POSA PLANARE IN QUALSIASI CONDIZIONE DI LAVORO.

When laying large tile sizes, there is a risk you will encounter differences in floor level. To offset uneven areas, we recommend using levelling spacers to guarantee a rapid and accurate fitting of the floor tiles in all conditions.

Um eventuelle Unebenheiten zu beseitigen, die bei der Verlegung von großformatigen Platten auftreten können, empfehlen wir dringend die Verwendung von nivellierenden Abstandhaltern, um bei allen Arbeitsbedingungen problemlos ein präzises, ebenes Ergebnis zu erzielen.

Pour éviter les dénivelés qui peuvent se créer en posant des plaques de grand format, il est vivement conseillé d'utiliser des écarteurs pour rattraper le niveau, afin d'obtenir facilement une pose plate, quelles que soient les conditions de travail.

Para eliminar los desniveles que puedan surgir al colocar las placas de gran formato, se aconseja el uso de separadores de nivelación para que se obtenga con facilidad y precisión una colocación plana en cualquier condición de trabajo.

MANUTENZIONE

MAINTENANCE / ENTRETIEN / PFLEGE UND REINIGUNG / MANTENIMIENTO

Dopo la pulizia di fine posa, eseguita a regola d'arte con prodotti disincrostanti, tale che ogni traccia di residuo di malta cementizia sia stata opportunamente tolta, i pavimenti sono idonei all'uso; si dovrà solo tenere conto di una pur minima necessità di manutenzione ordinaria che i pavimenti richiederanno nel tempo. Per la pulizia ordinaria dei pavimenti realizzati in CERDISASTONE si possono usare i normali detersivi per pavimenti ceramici, secondo le modalità d'uso consigliate dal produttore, dando la preferenza ai prodotti privi di cere, lacche ed in genere di sostanze lucidanti o abrasive. Nei rari casi in cui si rivelasse la necessità di una manutenzione straordinaria sarà opportuno studiare ogni singolo caso, per determinare quale sia la natura della sostanza o delle sostanze da eliminare e per adottare il metodo di pulizia più idoneo. E comunque buona norma per ogni tipo di macchia intervenire con la massima tempestività, perché ciò si è rivelato risolutivo per la maggioranza dei casi.

After cleaning on completion of laying, with anti-incrustating products, which must be carried out properly to remove all traces of cement mortar etc., the floor is ready for use. Very limited routine maintenance is required to ensure that the flooring retains its appearance over time. For routine cleaning of CERDISASTONE floor, normal detergents available on the market for ceramic floors can be used. Follow the instructions for use. Products without wax, waxes or other polishes or abrasive substances are recommended. If extraordinary maintenance is required, each case should be considered individually to establish the type of substances to be removed and decide on the most appropriate cleaning method. However, action should be taken to remove all marks as quickly as possible, as most stains can be eliminated if tackled immediately.

Après le nettoyage de fin de pose effectué selon les règles de l'art avec des produits détartrants dont il ne reste aucune trace de résidu de mortier de ciment, etc., les carrelages sont prêts. Il faudra seulement tenir compte d'un entretien ordinaire que les carreaux demanderont dans le temps. Pour le nettoyage normal des carreaux en CERDISASTONE, on peut utiliser les détergents pour carreaux céramiques que l'on trouve dans le commerce en suivant le mode d'emploi conseillé par le producteur et en donnant la préférence aux produits sans cires, laques et, général, substances polissantes et abrasives. Si, dans les rares cas, un entretien extraordinaire était nécessaire, il faudrait étudier chaque cas séparément pour déterminer la nature de la substance ou des substances à éliminer et pour adopter la méthode de nettoyage la plus appropriée. Il faut de règle intervenir le plus vite possible car cela est décisif dans la plupart des cas.

Nach einer fachgerechten Endreinigung mit Enkrustungsmitteln, bei der alle Mörtelreste usw., gründlich entfernt wurden, können die Fußböden benutzt werden. In der Folge ist nur ein Minimaler Aufwand an Pflege erforderlich. CERDISASTONE-Böden werden entsprechend den Gebrauchsanweisungen mit normalen, im Handel erhältlichen Reinigungsmitteln für Keramikfliesen gesäubert. Hierbei sollten vorzugsweise Produkte benutzt werden, die keine Wachse, Lacke, Glanz- oder Scheuermittel enthalten. Bei außergewöhnlichen Verschmutzungen sollte zuerst die Art der zu entfernenden Substanzen überprüft und dann die entsprechende Reinigungsmethode gewählt werden. Grundsätzlich sollten Flecken so schnell wie möglich entfernt werden. In den meisten Fällen erweist sich ein rasches Eingreifen als erfolgreich.

Una vez concluida la colocación de las baldosas, hace falta proceder a una detenida limpieza, utilizando productos idóneos, para eliminartodo residuo de mortero de cemento, etc.; con esto los pavimentos quedan listos para su uso; luego será necesario sólo un mínimo mantenimiento ordinario. Para la limpieza habitual de los pavimentos en CERDISASTONE pueden emplearse los detergentes normales para pavimentos cerámicos que se encuentran en el comercio; aténgase siempre a las instrucciones del productor, prefiriendo productos sin ceras, lacas ni sustancias abrillantadoras o abrasivas. En los raros casos en que resulte necesario un mantenimiento extraordinario, será oportuno estudiar cada caso particular, para determinar la naturaleza de la substancia o de las substancias a eliminar y para adoptar el método de limpieza más indicado. En todo caso es buena norma, para todo tipo de mancha, proceder a su eliminación con la máxima tempestividad, lo cual en la mayoría de los casos ha demostrado ser resolutorio.

TIPO DI MACCHIA TYPE OF STAIN / TYPE DE TACHE / FLECKENART TIPO SLASH DE MANCHA	DETERGENTE DETERGENTS / DÉTERGENT / REINIGUNGSMITTEL DETERGENTE
RESIDUI DI CEMENTO, DEPOSITI CALCAREI E TRACCE PIOMBATURA CEMENT RESIDUES, LIME SCALE DEPOSITS AND TRACES OF MATERIALS USED DURING POUSHING / RESIDUS DE MORTIER DÉPÔT DE CALCAIRE ET TRACES DE PLOMBAGE / ZEMNZTRUSTÄNDE, KALKLAGERUNGEN UND BLEISPUREN / RESIDUOS DE CEMENTO, DEPÓSITOS CALCAREOS Y TRAZAS DE EMPLOMADO	ACIDO DEBOLE ORGANICO (TIPO P100 DELLA CERDISA) WEAK ORGANIC ACID (SUCH AS CERDISAS P100) / ACIDE FAIBLE ORGANIQUE (TYPE P100 DE LA CERDISA) SCHWACHE ORGANISCHE SAURE (TYP P100 VON CERDISA) / ACIDO DÉBIL ORGANICO (TIPO P100 DE LA CERDISA)
MACCHIE DI RUGGINE RUST STAINS / TACHES DE ROUILLE / ROSTFLECKEN / MANCHAS DE HERRUMBLE	PREPARATI A BASE DI ACIDO FOSFORICO PHOSPHORIC ACID BASED PRODUCTS / PRODUITS À BASE D'ACIDE PHOSPHORIQUE / PRODUKT AUF DER BASIS VON PHOSPHORSÄURE / PREPARADOS A BASE DE ACÍDO FOSFÓRICO
OLII, GRASSI E CERA OIL, GREASE AND WAX / HUILES, GRAISSES ET CIRE / ÖL, FETT UND WACHS / ACEITE, GRASAS Y CERA	ALCOOL ETILICO A 90° PER OLI E TRIELINA PER I GRASSI O BICARBONATO E ACQUA O VAPORE 90° PROOF ALCOHOL FOR OIL AND TRICHLOROETHYLENE OR SODIUM BICARBONATE AND WATER OR STEAM FOR GREASE ALCOOL ETHYLIQUE À 90° POUR LES HUILES ET TRICHLOROETHYLENE POUR GRAISSES ON BICARBONATE ET EAU OU VAPEUR ETHYLALCOHOL / 90° FÜR ÖL UND TRICHLOROETHYLEN FÜR FETTE ODER BICARBONAT UND WASSER ODER DAMPF ALCOHOL ETILICO DE / 90° PARA LOS ACEITES Y TRICLOROETILENO (QUITAMANCHAS) PARA LAS GRASAS O BICARBONATO Y AGUA O VAPOR
MACCHIE DI CATRAME E BITUME E RESIDUI DI MALTA A BASE DI RESINE TAR, BITUMEN AND RESIN BASED MORTAR RESIDUES / TACHES DE GOUDRON ET DE BITUME ET RESIDUS DE MORTIER / TEER-UND BITUMENFLECKE SOWIE RÜCKSTÄNDE VON HARZMÖRTEL / MANCHAS DE ALQUITRAN, ASFALTO Y RESIDUOS DE MORTERO A BASE DE RESINAS	SOLVENTI ORGANICI A BASE DI CLORURO DI METILENE O ACETONE METHYLENE CHLORIDE BASED OR ACETONE BASED ORGANIC SOLVENTS / SOLVANTS ORGANIQUES À BASE DE CHLORURE DE METHYL OU ACETONE ORGANISCHE LÖSEMittel AUF DER BASIS VON METHYLCHLORID ODER ACETON / DISOLVENTES ORGANICOS A BASE DE CLORURO DE METILENO O ACETONA
GOCCHE DI COLORE E VERNICE PAINT SPOTS / GOUTTES DE COULEUR ET VERNIS / FARB-UND LACKTROPFEN / GOTAS DE PINTURA Y BARNITZ	SOLVENTE BASE DELLA VERNICE O SVERNICIATORE PER LEGNO SOLVENT USED IN PARTICULAR PAINT OR PAINT REMOVER FOR WOOD SURFACES / SOLVANT BASE DU VERNIS OU DÉCAPANT POUR BOIS / GRUNDLÖSEMittel FÜR LACK ODER ABBEZMittel FÜR HOLZ / DISOLVENTE BASE DEL BARNIZ O QUITABARNIZ PARA MADERA
GOMMA DA PNEUMATICO TYRE RUBBER / CAOUTCHOUC DE PNEUMATIQUE / GUMMI / GOMA DA NEUMÁTICO	SOLVENTE ORGANICO ORGANIC SOLVENT / SOLVANT ORGANIQUE / ORGANISCHES LÖSEMittel / DISOLVENTE ORGANICO
BIRRA - VINO BEER - WINE / BIÈRE - VIN / BIER, WEIN / CERVEZA - VINO	DETERGENTE ALCALINO, HD WASH PURO ALKALINE DETERGENT, NEAT HD WASH / DÉTERGENT ALCALIN, HD WASH PUR / ALKALINES REINIGUNGSMittel, UNVERDÜNNTES HD WASH / DETERGENTE ALCALINO HD WASH PURO
IODIO IODINE / IODE / JOD / YODO	AMMONIACA AMMONIA / AMMONIAQUE / AMMONIAK / AMONIAK
SANGUE BLOOD / SANG / BLUT / SANGRE	ACQUA OSSIGENATA O IPOCLORITO DI SODIO (CANDEGGINA) HYDROGEN PEROXIDE OR SODIUM HYPOCHLORITE (BLEACH) / EAU OXYGÉNÉE OU HYPOCHLORITE DE SODIUM (EAU DE JAVEL) WASSERSTOFFSUPEROXID ODER NARIUMHYPOCHLORIT (CHLORLAUGE) / AGUA OXIGENADA O HIPOCLORITO DE SODIO (LEJÍA)
CAFFÈ, THÉ, ALIMENTI, COSMETICI, SUCCHI DI FRUTTA COFFEE, TEA, FOODSTUFFS, COSMETICS, FRUIT JUICE / CAFÉ, THÉ, ALIMENTS, COSMÉTIQUE, JUS DE FRUITS KAFFEE, TEE, LEBENSMITTEL, KOSMETIKA, OBSTSAFTE / CAFÉ, TÉ, ALIMOTOS, COSMÉTICOS, JUGOS DE FRUTA	COMUNE DETERSIVO IN ACQUA CALDA, POI, ACQUA OSSIGENATA O CANDEGGINA, HD WASH PURO HOT WATER + NORMAL DETERGENT FOLLOWED BY HYDROGEN PEROXIDE OR BLEACH, NEAT HD WASH / DÉTERSIF COMMUN EN EAU CHAUDE, PUIS, EAU OXYGÉNÉE OU EAU DE JAVEL, HD WASH PUR / ÜBLICHES REINIGUNGSMittel IN WARME WASSER, DANN WASSERSTOFFSUPEROXID ODER CHLORLAUGE, UNVERDÜNNTES HD WASH / DETERGENTE CORRIENTE EN AGUA CALIENTE, DESPUÉS, AGUA OXIGENADA O LEJÍA HD WASH PURO
INCHIOSTRO, BITUME, MERCUROCROMO INK, BITUMEN, MERBROMIN, BASED ANTISEPTICS / ENCRE, BITUME, MERCUROCHROME / TINTE, BITUMEN, MERCUROCHROM / TINTA, ASFALTO, MERCROMINA	SOLUZIONI DILUITE DI IPOCLORITO DI SODIO (CANDEGGINA) DILUTED SODIUM HYPOCHLORITE SOLUTION (BLEACH) / SOLUTIONS DILUÉS DE HYPOCHLORITE DE SODIUM (EAU DE JAVEL) VERDÜNNTTE NARIUMHYPOCHLORIDLÖSUNGEN (CHLORLAUGE) / SOLLUCIONES DILUIDAS DE HIPOCLORITO DE SODIO (LEJÍA)
PULIZIA QUOTIDIANA ROUTINE DAILY CLEANING / NETTOYAGE JOURNALIER / TÄGLICHE REINIGUNG / LIMPIEZA DIARIA	NORMALI DETERGENTI DA PAVIMENTO ACQUA E ALCOOL ETILICO, HD WASH DILUITO IN ACQUA COME INDICATO NORMAL FLOOR DETERGENTS, WATER + ALCOHOL, DILUTED HD WASH FOLLOWING INSTRUCTIONS / DETERGENTS USUEL POUR SOL, EAU ET ALCOOL ETHYLIQUE, HD WASH DILUE DANS LEAU COMME INDIQUE / NORMALE BODENREINIGER, WASSER UND ETHYLALHOL, GEMÄSS ANWEISUNG IN WASSER UNVERDÜNNTES HD WASH / DETERGENTES CORRIENTES PARA SUELOS, AGUA Y ALCOHOL ETILICO, HD WASH DILUITO EN AGUA COMO ESTÁ INDICADO
DETERGENTE A BASE ACIDA ACID BASED DETERGENTS / SOLUTIONS ACIDES / SAÛRE REINIGUNGSMittel / DETERGENTES DE BASE ACIDA	DETERGENTE A BASE ALCALINA ALKALINE BASED DETERGENTS SOLUTIONS ALCALINES / ALKALINE REINIGUNGSMittel / DETERGENTES DE BASE ALCALINA
ACIDO MURIATICO HYDROCHLORIC ACID / ACIDE CHLORHYDRIQUE / SALZSÄURE / ACIDO MURIÁTICO	SODA CAUSTICA CAUSTIC SODA / SOUDE CAUSTIQUE / NATRON / SODA CAÚSTICA
ACIDO NITRICO NITRIC ACID / ACIDE NITRIQUE / SALPETERSÄURE / ACIDO NITRICO	POTASSA POTASSIUM CARBONATE / POTASSE / POTTASCH / POTASA
ACIDO OSSALICO OXALIC ACID / ACIDE OXALIQUE / OXALSÄURE / ACIDO OXÁLICO	
ACIDO SOLFORICO SULFURIC ACID / ACIDE SULFURIQUE / SCHWEFELSÄURE / ACIDO SULFÚRICO	

NOTE

A series of horizontal dotted lines spanning the width of the page, providing a structured area for taking notes.

AREATECH

Gres fine porcellanato Bla UGL EN 14411 / Fine porcelain stoneware / Feinsteinzeug / Grès cérame fin / Gres fino porcelánico

Caratteristica Features Características Eigenschaften Características	Unità di misura Unit of measurement Unité de mesure Masseinheit Unidad de medida	Valore medio Areatech Areatech mean value Valeur moyenne Areatech Mittelwert Areatech Valor medio Areatech	Valore Prescritto Fixed value Valeur prescrite Vorgeschriebener wert Valor establecido	Metodo di prova Test method Méthode d'essai Prüfmethode Método de ensayo
Dimensione lati Dimensions-Lenght and width Laenge und Breite Dimensions-Longueur et largeur Dimensiones-Longitud y ancho	%	Conforme Conform Anforderungen erteilt Conforme Conforme	+/- 0,6 MAX +/- 2,0 mm	UNI EN ISO 10545-2
Rettilinearità dei lati Side straightness Kantengeradheit Rectitude des arêtes Rectilínedad de los lados	%	Conforme Conform Anforderungen erteilt Conforme Conforme	+/- 0,5 MAX +/- 1,5 mm	UNI EN ISO 10545-2
Ortogonalità degli spigoli Corner squariness Rechtwinkligkeit der Kanten Angularité Ortogonalidad de las esquinas	%	Conforme Conform Anforderungen erteilt Conforme Conforme	+/- 0,5 MAX +/- 2,0 mm	UNI EN ISO 10545-2
Planarità Flatness Ebenflächigkeit Planéité Planeidad	%	Conforme Conform Anforderungen erteilt Conforme Conforme	+/- 0,5 MAX +/- 2,0 mm	UNI EN ISO 10545-2
Spessore Thickness Stärke Épaisseur Grosor	%	Conforme Conform Anforderungen erteilt Conforme Conforme	+/- 5 MAX +/- 0,5 mm	UNI EN ISO 10545-2
Assorbimento d'acqua Water absorption Wasseraufnahme Absorption d'eau Absorción de agua	%	Conforme Conform Anforderungen erteilt Conforme Conforme	≤ 0,5	UNI EN ISO 10545-3
Resistenza all'abrasione profonda Resistance to abrasion Tiefenabriebfestigkeit Résistance à l'abrasion Resistencia à la abrasión	MM ³	Conforme Conform Anforderungen erteilt Conforme Conforme	≤ 175	UNI EN ISO 10545-6
Resistenza al gelo Frost resistance Frostbeständigkeit Résistance au gel Resistencia al hielo	-	Resiste Resists Anforderungen erteilt Résiste Resiste	Richiesta Request Nach Anforderung Demande Solicitud	UNI EN ISO 10545-12
Sforzo di rottura Breaking strenght Biegefestigkeit Contrainte de rupture Esfuerzo de rotura	N	Conforme Conform Anforderungen erteilt Conforme Conforme	≥ 1300 se sp ≥ 7,5 mm ≥ 700 se sp < 7,5 mm	UNI EN ISO 10545-4
Modulo di rottura Modulus of rupture Bruchmodul Coefficient de rupture Módulo de rotura	N/mm ²	Conforme Conform Anforderungen erteilt Conforme Conforme	≥ 35	UNI EN ISO 10545-4
Dilatazione termica lineare Coeff. of linear thermal expansion linearer Waermedehnungskoeffizient Coeff. d'extension thermique linéaire Coeficiente de dilatación térmica lineal	°MK (-1)	7,0	-	UNI EN ISO 10545-8
Resistenza ai prodotti chimici di uso domestico Resistance to chemicals for household use Widerstandsfähigkeit gegen Haushaltschemikalien Résistance aux produits d'usage domestique Resistencia a los productos químicos de uso doméstico	-	Conforme Conform Anforderungen erteilt Conforme Conforme	UB	UNI EN ISO 10545-13
Resistenza agli sbalzi termici thermal shock resistance Widerstandsfähigkeit gegen Temperaturschwankungen résistance aux écarts de température resistencia al choque térmico	-	Conforme Conform Anforderungen erteilt Conforme Conforme	Richiesta Request Onfrage Demande Solicitud	UNI EN ISO 10545-9
Stabilità dei colori Colour stability Lichtbeständigkeit der Farben Stabilité des coloris Estabilidad de los colores	-	Resiste Resists Widerstandsfähig Résiste Resiste	Richiesta Request Onfrage Demande Solicitud	DIN 51094

	Tipo di struttura Structural characteristic Caractéristiques structurelles Trittsicherheitsgruppen Tipo de estructura	Unità di misura Unit of measurement Unité de mesure Masseinheit Unidad de medida	Valore medio Areatech Areatech mean value Valeur moyenne Areatech Durchschnitts-werf-Areatech Valor medio Areatech	Conforme a: conform to: conforme à: gemäß: conform a:
Scivolosità Slip factor Glätte Glissance Resbalamiento	Archistone Naturale	Gradi	A R9	DIN 51097 DIN 51130
	Archistone Grip (Darkstone/Lightstone/Pietra di Bavaria)	Gradi	A+B R10	DIN 51097 DIN 51130
	Archistone Grip (Grafite/Limestone)	Gradi	C (A+B+C) R11	DIN 51097 DIN 51130
	EC1 Naturale	Gradi	A R10	DIN 51097 DIN 51130
	EC1 Strutturato	Gradi	C (A+B+C) R12	DIN 51097 DIN 51130
	Formwork Naturale	Gradi	A R9	DIN 51097 DIN 51130
	Formwork Grip	Gradi	C (A+B+C) R11	DIN 51097 DIN 51130
	Graniti - Slate	Gradi	A R11	DIN 51097 DIN 51130
	Graniti/Tinte Unite - Trama Cross	Gradi	C R12 V4	DIN 51097 DIN 51130
	Hamada	Gradi	A+B R11	DIN 51097 DIN 51130
	Paver	Gradi	B (A+B) R 10	DIN 51097 DIN 51130
	Pietra Piasentina	Gradi	A R9	DIN 51097 DIN 51130
	Pietra Piasentina Grip	Gradi	A R10	DIN 51097 DIN 51130
	Pietraforte	Gradi	B (A+B) R 11	DIN 51097 DIN 51130
	Portland	Gradi	R9	DIN 51130
	Sandstone	Gradi	A R10	DIN 51097 DIN 51130
Stone Cult	Gradi	R9	DIN 51130	
Scivolosità - Attrito asciutto Slip factor - Friction on a dry surface Glätte - Rutschhemmung auf einer trockenen oberfläche Glissance - Déparage sur une surfacemouillée Resbalamiento - Fricción en seco	Archistone Grip	-	> 0,60	ASTM C 1028
	EC1 Naturale	-	> 0,60	ASTM C 1028
	EC1 Strutturato	-	> 0,60	ASTM C 1028
	Formwork Grip	-	> 0,60	ASTM C 1028
	Hamada	-	> 0,60	ASTM C 1028
	Paver	-	> 0,60	ASTM C 1028
	Pietra Piasentina	-	> 0,60	ASTM C 1028
	Pietra Piasentina	-	> 0,60	ASTM C 1028
	Pietraforte	-	> 0,60	ASTM C 1028
	Sandstone	-	> 0,60	ASTM C 1028
	Stone Cult	-	> 0,60	ASTM C 1028
Scivolosità - Attrito bagnato Slip factor - Friction on a wet surface Glätte - Rutschhemmung auf einer naßen fläche Glissance - Déparage sur une surfacessuyée Resbalamiento - Fricción en húmedo	Archistone Grip	-	> 0,60	ASTM C 1028
	EC1 Naturale	-	> 0,60	ASTM C 1028
	EC1 Strutturato	-	> 0,60	ASTM C 1028
	Formwork Grip	-	> 0,60	ASTM C 1028
	Hamada	-	> 0,60	ASTM C 1028
	Paver	-	> 0,60	ASTM C 1028
	Pietra Piasentina	-	> 0,60	ASTM C 1028
	Pietraforte	-	> 0,60	ASTM C 1028
	Sandstone	-	> 0,60	ASTM C 1028
	Stone Cult	-	da 0,50 a 0,60	ASTM C 1028

PRODOTTI ANTISCIVOLO

NON-SLIP PRODUCT / RUTSCHSICHERE PRODUKTE / LES PRODUITS ANTIGLISSE / LOS PRODUCTOS ANTIDESLIZAMENTO

SCIVOISITÀ secondo ASTM C 1028

Il metodo di prova statunitense ASTM C 1028 prevede la misurazione della scivolosità di un pavimento per mezzo di un test che, utilizzando uno strumento normalizzato, rileva il coefficiente statico di attrito. La prova viene eseguita con tampone in cuoio, in gomma e in neolite, con superficie asciutta e bagnata. Il risultato è valutato secondo la seguente classificazione:

inferiore a	0,50	attrito insufficiente
da	0,50 a 0,60	attrito sufficiente
superiore a	0,60	anti-slip

Nelle tabelle sono riportati solo i dati relativi al test eseguito con tampone in neolite e soltanto per quei prodotti che vengono proposti per impieghi in cui è espressamente richiesta l'antiscivolosità.

SLIPPERINESS according to ASTM C 1028

The US testing method ASTM C 1028 measures the slipperiness of a flooring through a test that, by means of a standardized instrument, measures the static friction coefficient. The test is made with rubber, leather and neolite pads, with wet and dry surface.

The result is evaluated according to the following classification:

lower than	0,50	insufficient friction
from	0,50 a 0,60	sufficient friction
over	0,60	anti-slip

The tables show only the data relevant to the test made with neolite pad and only for those products suggested for uses where the slipping resistance is expressly recommended.

RUTSCHGEFAHR nach ASTM C 1028

Die amerikanische Testmethode ASTM C 1028 mißt die Rutschgefahr in einem Boden über einen Test, der durch ein normalisiertes Instrument den statischen Reibungskoeffizienten ermittelt. Der Test erfolgt mit Hilfe eines Leder-, Gummi- und Neolitpuffers mit trockener und nasser Oberfläche.

Das Resultat wird nach folgender Klassifizierung bewertet:

unter	0,50	ungenügende Reibung
von	0,50 a 0,60	ausreichende Reibung
über	0,60	anti-slip

Die Tabellen enthalten nur die Daten in bezug auf den mit Neolitpuffer ausgeführten Tests für die Produkte, die nur dann eingesetzt werden, wenn ausdrückliche Rutschfestigkeit verlangt wird.

GUSSEMENT conformément à la norme ASTM C 1028

La méthode d'essai des Etats-Unis ASTM C 1028 prévoit la mesure du glissement d'un carrelage, par un essai effectué en utilisant un instrument normalisé, qui détermine le coefficient statique de friction. L'essai est effectué à l'aide d'un tampon en cuir, d'un tampon en caoutchouc et d'un tampon en néolithe, soit pour la surface sèche, pour la surface mouillée. Le résultat est évalué sur la base du classement suivant:

moins de	0,50	friction insuffisante
de	0,50 a 0,60	friction suffisante
plus de	0,60	antiglisement

Les tableaux réportent uniquement les données concernant l'essai effectué à l'aide du tampon en néolithe et pour les seuls produits qui sont proposés pour des emplois où la caractéristique d'antiglisement est expressément demandée.

DESLIZAMIENTO según el método ASTM C 1028

El método estadounidense de prueba ASTM C 1028 prevé la medición del índice de deslizamiento de un pavimento por medio de un test que, sirviéndose de un instrumento reglamentario, determina el coeficiente de rozamiento estático del mismo. La prueba se lleva a cabo con una correa de cuero, de goma y de neolite, sobre superficie seca y mojada.

La evaluación se establece de acuerdo con la siguiente clasificación:

inferior a	0,50	roce insuficiente
da	0,50 a 0,60	roce suficiente
superior a	0,60	antideslizamiento

En las tablas se indican únicamente los datos correspondientes a la prueba efectuada con correa de neolite y sólo en referencia a los productos que se utilizan cuando se requiere de manera expresa que el pavimento sea antideslizante.

Categoria di resistenza allo scivolamenti con piedi calzati

Slip resistance group with footwear

Categories de resistance au glissement les pieds chaussés

Rutschhemmungskategorien mit schuhwerk

Categoría de resistencia al resbalamiento con zapatos en los pies

ZH1/571 - DIN 51130

SUPERFICIE DI CALPESTIO
SURFACE TO WALK ON - SURFACE DE PIÉTINEMENT
TRITTFÄCHE - SUPERFICIE DE TRAFICO PEATONAL

SPAZIO DI RACCOLTA
COLLECTION SPACE - ESPACE DE RÉCUPÉRATION
VERDRÄNGUNGSRAUM - ESPACIO DE RECÓGIDA

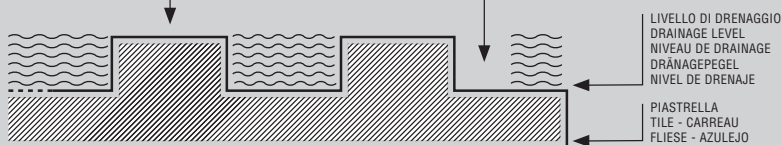

CONTRASSEGNO DELLO SPAZIO DI RACCOLTA
COLLECTION SPACE MARK
IDENTIFICATION DE L'ESPACE DE RÉCUPÉRATION
KENNZAHL FÜR VERDRÄNGUNGSRAUM
MARCA DE IDENTIFICACION DEL ESPACIO DE RECÓGIDA

VOLUME MIN. DELLO SPAZIO DI RACCOLTA (CM³/DM²)
MIN. VOLUME OF COLLECTION SPACE (CM³/DM²)
VOLUME MIN. DE L'ESPACE DE RÉCUPÉRATION (CM³/DM²)
MINDESTVOLUMEN VERDRÄNGUNGSRAUMES (CM³/DM²)
VOLUMEN DEL ESPACIO DE RECÓGIDA (CM³/DM²)

V4	→	4
V6	→	6
V8	→	8
V10	→	10

COEFFICIENTE DI ATTRITO
COEFFICIENT OF FRICTION
COEFFICIENT DE FRICTION
REIBUNGSKOEFFIZIENT
COEFICIENTE DE FRICCIÓN

ANGOLI DI INCLINAZIONE
ANGLE
ANGLE D'INCLINAISON
NEIGUNGSWINKEL
ÁNGULOS DE INCLINACIÓN

CAMPI DI APPLICAZIONE
FIELD OF APPLICATION
DOMAINES D'UTILISATION
ANWENDUNGSBEREICH
CAMPOS DE APLICACIÓN

R9		6° ÷ 10°	AMBIENTI RESIDENZIALI, SCUOLE, STUDI MEDICI, ECC. - RESIDENTIAL ENVIRONMENTS, SCHOOLS, SURGERIES, ETC. - MILIEUX RÉSIDENTIELS, ÉCOLES, CABINETS DE MÉDECINS, ETC. - WOHNBEREICH, SCHULEN, ARZTPRAXEN USW. - AMBIENTES RESIDENCIALES, ESCUELAS, SERVICIOS MÉDICOS, ETC.
R10		10° ÷ 19°	TOILETTES, MAGAZZINI, GARAGES, CUCINE DI LOCALI PUBBLICI ECC. - BATHROOMS, WAREHOUSES, GARAGES, KITCHENS OF RESTAURANT, ETC. - TOILETTES, MAGASINS, GARAGES, CUISINES D'ÉTABLISSEMENTS PUBLICS, ETC. - TOILETTEN, LAGERHALLEN, GARAGEN, GROßKÜCHEN USW. - RETRETES, ALMACENES, GARAJES, COCINAS, LOCALES PÚBLICOS, ETC.
R11		19° ÷ 27°	LAVORAZIONE FORMAGGI, CELLE FRIGORIFERE, LAVANDERIE, ECC. - DAIRIES, COLD ROOMS, LAUNDRIES, ETC. - TRAVAIL DU FROMAGE, CHAMBRES FRIGORIFIQUES, BLANCHISSERIES, ETC. - KÄSEREI, WÄSCHEREI, KÜHLRÄUME, USW. TRANSFORMACIÓN QUESOS, CELDAS FRIGORÍFICAS, LAVANDERÍAS, ETC.
R12		27° ÷ 35°	LAVORAZIONE CARNI, CUCINE INDUSTRIALI, ZUCCHERIFICI, ECC. - MEAT PROCESSING, INDUSTRIAL KITCHENS, SUGAR PRODUCTION, ETC. - TRAVAIL DE LA VIANDE, CUISINES INDUSTRIELLES, SUCRERIES, ETC. - FLEISCHVERARBEITUNGSTÄTTEN, INDUSTRIEKÜCHEN, ZUCKERFABRIKEN, USW. - TRANSFORMACIÓN CARNES, COCINAS INDUSTRIALES, AZUCARERÍAS, ETC.

Pavimentazioni per zone bagnate con calpestio a piedi scalzi



Slip proof products flooring for wet areas used when barefoot

Sols pour zones mouillées de cheminement pieds nus

Für Böden in Nassbereichen mit barfußbegehung

Pavimentaciones para zonas mojadas con tráfico peatonal con pies descalzos

GUV. 26.17 - DIN 51097

GRUPPO DI CLASSIFICAZIONE EVALUATION GROUP GROUPE D'EVALUATION BEWERTUNGSGRUPPE GRUPOS DE EVALUACION	ANGOLO MINIMO DI INCLINAZIONE MINIMUM ANGLE OF SLOPE ANGLE MIN. D'INCLINAISON MINIMALER NEIGUNGSWINKEL ANGULO MÍNIMO DE INCLINACION
A	→ ≥12° 
B	→ ≥18° 
C	→ ≥24° 

GRUPPO DI VALUTAZIONE	ANGOLO MIN. DI INCLINAZIONE	ELENCO DELLE ZONE BAGNATE CON CALPESTIO A PIEDI SCALZI
A	12°	- CORRIDOI PER CALPESTIO CON PIEDI SCALZI (PER LO PIÙ SECCHI) - SPOGLIATOI SINGOLI O DI GRUPPO - FONDI DI PISCINE BASSE, QUANDO IN TUTTA LA PISCINA LA PROFONDITÀ NON SUPERA GLI 80 CM.
B	18°	- CORRIDOI PER CALPESTIO CON PIEDI SCALZI NON FACENTI PARTE DELLA CATEGORIA A - DOCCE - ZONE DI IMPIANTI DI SPRIZZATURA DI DISINFETTANTI - PASSAGGIO INTORNO ALLE PISCINE - FONDI DI PISCINE BASSE, QUANDO IN DETERMINATI PUNTI DELLA VASCA LA PROFONDITÀ DELL'ACQUA È INFERIORE A 80 CM. - FONDI DI VASCHE IN PISCINE BASSE A ONDE - PIANI DI SOLLEVAMENTO - PISCINE PER BAMBINI - SCALE A PIOLI CHE PORTANO IN ACQUA - SCALE CHE PORTANO IN ACQUA CON LARGHEZZA MAX DI 1 M. CON CORRIMANO SU ENTRAMBI I LATI - SCALE A PIOLI E SCALE ALL'ESTERNO DELLA ZONA DELLA VASCA
C	24°	- SCALE CHE PORTANO IN ACQUA NON FACENTI PARTE DELLA CATEGORIA B - VASCHE PER PASSAGGIO - BORDO PISCINA INCLINATO

GRUPE D'EVALUATION	ANGLE MIN. DINCLINAISON	LISTE DES ZONES MOUILLÉES AVEC PIÉTINEMENT PIEDS NUS
A	12°	- COULOIRS DE CHEMINEMENT PIEDS NUS (LE PLUS SOUVENT SECS) - VESTIAIRES INDIVIDUELS OU DE GROUPE - FONDS DE PISCINES BASSES, AVEC TOUTE LA PROFONDEUR NE DÉPASSANT PAS 80 CM.
B	18°	- COULOIRS DE CHEMINEMENT PIEDS NUS NE FAISANT PAS PARTIE DE LA CATÉGORIE A - DOUCHES - ZONES D'INSTALLATION DE VAPORISATION DE DÉSINFECTANTS - PASSAGE AUTOUR DES PISCINES - FONDS DE PISCINES BASSES, AVEC UNE PROFONDEUR INFÉRIEURE À 80 CM EN CERTAINS POINTS - FONDS DU BASSIN DANS LES PISCINES BASSES À VAGUES - PLANS DE SOULÈVEMENT - PISCINES POUR ENFANTS - ÉCHELLES MURALES D'ENTRÉE DANS L'EAU - ESCALIERS D'ENTRÉE DANS L'EAU D'UNE LARGEUR D'1M MAX. AVEC RAMPE DES DEUX CÔTÉS - ÉCHELLES ET ESCALIERS SITUÉS À L'EXTÉRIEUR DE LA ZONE DU BASSIN
C	24°	- ESCALIERS D'ENTRÉE DANS L'EAU NE FAISANT PAS PARTIE DE LA CATÉGORIE B - BASSINS DE PASSAGE - BORD DE PISCINE INCLINÉ

EVALUATION GROUP	MIN. ANGLE OF SLOPE	LIST OF WET AREAS TO BE WALKED ON BAREFOOT
A	12°	- CORRIDORS USED WHEN BAREFOOT (GENERALLY WHEN DRY) - SINGLE OR GROUP CHANGING ROOMS - BOTTOMS OF SHALLOW SWIMMING POOLS, WHEN THE DEPTH DOES NOT EXCEED 80 CM. IN THE ENTIRE SWIMMING POOL
B	18°	- CORRIDORS USED WHEN BAREFOOT, NOT COVERED BY CATEGORY A - SHOWERS - AREAS WITH SYSTEMS FOR SPRAYING DISINFECTANT - AREAS AROUND THE SWIMMING POOL - BOTTOMS OF SHALLOW SWIMMING POOLS WHEN THE DEPTH OF THE WATER IS LESS THAN 80 CM. AT CERTAIN POINTS IN THE POOL - BOTTOMS OF SHALLOW SWIMMING POOLS WITH WAVE MACHINE - PLATFORMS - BABY POOLS - LADDERS LEADING INTO WATER - STEPS LEADING INTO WATER WITH A MAX. WIDTH OF 1 M. WITH A HANDRAIL ON BOTH SIDES - LADDERS AND STEPS OUTSIDE THE POOL AREA - LADDERS LEADING INTO WATER NOT COVERED BY CATEGORY B - WALK THROUGH POOLS - SLOPING EDGES OF SWIMMING POOLS
C	24°	- LADDERS LEADING INTO WATER NOT COVERED BY CATEGORY B - WALK THROUGH POOLS - SLOPING EDGES OF SWIMMING POOLS

GRUPO DE EVALUACION	ANGULO MÍNIMO DE INCLINACION	ELENCO DE LA ZONAS MOJADAS CON TRAFICO PEATONAL CON PIES DESCALZOS
A	12°	- PASILLOS PARA TRÁFICO PEATONAL CON PIES DESCALZOS (LA MAYORÍA SECOS) - VESTUARIOS INDIVIDUALES O DE GRUPO - FONDOS DE PISCINAS BAJAS, CUANDO EN TODA LA PISCINA LA PROFUNDIDAD NO SUPERA LOS 80 CM.
B	18°	- PASILLOS PARA EL TRÁFICO PEATONAL CON PIES DESCALZOS QUE NO FORMAN PARTE DE LA CATEGORÍA A - DUCHAS - ZONAS DE INSTALACIONES DE PULVERIZACIÓN DE DESINFECTANTES - PASO ALREDEDOR DE LA PISCINA - FONDOS DE PISCINAS BAJAS CUANDO EN DETERMINADOS PUNTOS DE LA PISCINA LA PROFUNDIDAD DEL AGUA ES INFERIOR A 80 CM. - FONDOS DE PISCINAS BAJAS CON OLAS - PLANOS DE ELEVACION - PISCINAS PARA NIÑOS - ESCALERAS DE MANO QUE LLEVAN AL AGUA - ESCALERAS QUE LLEVAN AL AGUA CON UNA ANCHURA MÁX. DE 1 M. CON BARANDILLAS EN AMBOS LADOS - ESCALERAS DE MANO Y ESCALERAS EN EL EXTERIOR DE LA ZONA DE LA PISCINA
C	24°	- ESCALERAS QUE LLEVAN AL AGUA QUE NO FORMAN PARTE DE LA CATEGORÍA B - PISCINAS DE PASO - BORDE DE PISCINA INCLINADO

BEWERTUNGSGRUPPE	MINDEST-NEIGUNGSWINKEL	RUTSCHHEMMUNG IN BARFUSSBEREICHEN
A	12°	- BARFUSSGÄNGE (WEITGEHEND TROCKEN) - EINZEL-UND SAMMELUMKLEIDERÄUME - BECKENBÖDEN IN NICHTSCHWIMMERBEREICHEN, WENN IM GESAMTEN BEREICH DIE WASSERTIEFE NICHT MEHR ALS 80 CM. BETRÄGT
B	18°	- BARFUSSGÄNGE, SOWEIT SIE NICHT A ZUGEORDNET SIND - DUSCHRÄUME - BEREICHE VON DESINFIZIATIONSSPRÜHANLAGEN - BECKENRANDUMGEBUNGEN - BECKENBÖDEN IN NICHTSCHWIMMERBEREICHEN, WENN IN TEILBEREICHEN DIE WASSERTIEFE WENIGER ALS 80 CM. BETRÄGT - BECKENBÖDEN IN NICHTSCHWIMMERBEREICHEN VON WELLENBÄDERN - HUBBÖDEN - KINDERPLANSCHBECKEN - INS WASSER FÜHRENDE SPROSSENLEITERN - INS WASSER FÜHRENDE, MAX. 1 M. BREITE TREPPEN MIT BEIDSEITIGEN HANDLÄUFEN - SPROSSENLEITERN UND TREPPEN AUSSERHALB DES BECKENBEREICHES
C	24°	- INS WASSER FÜHRENDE TREPPEN, SOWEIT SIE NICHT B ZUGEORDNET SIND - DURCHGANGSBECKEN - GENEIGTE BECKENRANDAUSBILDUNGEN

PRODOTTI ANTISCIVOLO

NON-SLIP PRODUCT / RUTSCHSICHERE PRODUKTE / LES PRODUITS ANTIGLISSE / LOS PRODUCTOS ANTIDESLIZAMENTO

BOT 3000 - COEFFICIENTE DI ATTRITO DINAMICO (DCOF: DYNAMIC COEFFICIENT OF FRICTION)

Il metodo di prova BOT3000 prevede la misurazione del coefficiente di attrito dinamico di un pavimento in ceramica. La prova viene eseguita in condizioni di superficie bagnata in quattro direzioni ortogonali tra loro, utilizzando un sensore in gomma con caratteristiche normalizzate (ad esempio SBR).

Come indicato nella Norma ANSI A137.1-2012 il coefficiente determinato deve essere maggiore di 0,42 per superfici per le quali sia prevista la possibilità di deambulazione sul bagnato.

BOT 3000 (ACUTEST) - DYNAMIC COEFFICIENT OF FRICTION (DCOF)

The BOT3000 test method measures the dynamic coefficient of friction of a ceramic floor. The test is conducted on a wet surface in four orthogonal directions, using a rubber sensor with normalised characteristics (for example SBR).

As indicated in the ANSI A137.1-2012 standard, the code requires a minimum wet dynamic coefficient of friction (DCOF) of 0.42 for tiles in level interior spaces expected to be walked upon when wet.

BOT 3000 (ACUTEST) - DYNAMISCHER REIBUNGSKOEFFIZIENT (DCOF: DYNAMIC COEFFICIENT OF FRICTION)

Die Testmethode BOT3000 sieht die Messung des dynamischen Reibungskoeffizienten eines Keramikfußbodens vor. Der Test wird auf nasser Oberfläche in vier Richtungen, die im rechten Winkel zu einander stehen, mit Hilfe eines genormten Gummisensors (zum Beispiel SBR) durchgeführt.

Laut Norm ANSI A137.1-2012 muss der ermittelte Koeffizient bei Oberflächen, auf denen die Möglichkeit besteht, dass sie im nassen Zustand betreten werden, über 0,42 liegen.

BOT 3000 (ACUTEST) - DYNAMISCHER REIBUNGSKOEFFIZIENT (DCOF: DYNAMIC COEFFICIENT OF FRICTION)

La méthode d'essai BOT3000 permet de mesurer le coefficient de frottement dynamique sur un sol en céramique. Le test est effectué sur une surface mouillée, en quatre directions orthogonales l'une par rapport à l'autre, à l'aide d'un capteur en caoutchouc présentant des caractéristiques normalisées (par exemple SBR).

Comme l'indique la norme ANSI A137.1-2012, le coefficient déterminé doit être supérieur à 0,42 pour des sols sur lesquels il est prévu de marcher quand ils sont mouillés.

BOT 3000 - COEFFICIENTE DE FRICCIÓN DINÁMICO (DCOF: DYNAMIC COEFFICIENT OF FRICTION)

El método de prueba BOT3000 prevee la medición del coeficiente de fricción dinámico de un pavimento de cerámica. La prueba se efectua sobre superficies mojadas en 4 direcciones ortogonales entre ellas y se utiliza un sensor de goma con características normalizadas (por ejemplo, SBR).

Tal como especificado en la norma ANSI A137.1-2012, el coeficiente obtenido debe ser mayor de 0,42 para aquellas superficies que preveen la posibilidad de andar sobre suelo mojado.

CERDISASTONE

Gres porcellanato colorato in massa EN 14411 Bla / Colorbody porcelain stoneware / Durhgefärbtes steinzeug
Grès cérame coloré dans le masse / Gres porcelánico coloreado en toda la masa

Caratteristica Features Características Eigenschaften Características	Unità di misura Unit of measurement Unité de mesure Masseinheit Unidad de medida	Valore medio Cerdisa Cerdisa mean value Conform Valeur moyenne Cerdisa Mittelwert Cerdisa Valor medio Cerdisa	Valore Prescritto Fixed value Valeur prescrite Vorgeschriebener wert Valor establecido	Metodo di prova Test method Méthode d'essai Prüfmethode Método de ensayo
Dimensione lati Dimensions-Lenght and widht Laenge und Breite Dimensions-Longueur et largeur Dimensiones-Longitud y ancho	%	Conforme Conform Anforderungen erfuellt Conforme Conforme	+/- 0,6 MAX +/-2,0 mm	UNI EN ISO 10545-2
Rettilineità dei lati Side straightness Kantengeradheit Rectitude des arêtes Rectilíneidad de los lados	%	Conforme Conform Anforderungen erfuellt Conforme Conforme	+/- 0,5 MAX +/- 1,5 mm	UNI EN ISO 10545-2
Ortogonalità degli spigoli Corner squaranness Rechtwinkligkeit der Kanten Angularité Ortogonalidad de las esquinas	%	Conforme Conform Anforderungen erfuellt Conforme Conforme	+/- 0,5 MAX +/- 2,0 mm	UNI EN ISO 10545-2
Planarità Flatness Ebenflächigkeit Planéité Planeidad	%	Conforme Conform Anforderungen erfuellt Conforme Conforme	+/- 0,5 MAX +/- 2,0 mm	UNI EN ISO 10545-2
Spessore Thickness Stärke Epaisseur Grosor	%	Conforme Conform Anforderungen erfuellt Conforme Conforme	+/- 5 MAX +/- 0,5 mm	UNI EN ISO 10545-2
Assorbimento d'acqua Water absorption Wasseraufnahme Absorption d'eau Absorción de agua	%	Conforme Conform Anforderungen erfuellt Conforme Conforme	≤ 0,5	UNI EN ISO 10545-3
Sforzo di rottura Breaking strenght Biegefestigkeit Contrainte de rupture Esfuerzo de rotura	N	Conforme Conform Anforderungen erfuellt Conforme Conforme	≥ 1300 se sp ≥7,5 mm ≥ 700 se sp <7,5 mm	UNI EN ISO 10545-4
Modulo di rottura Modulus of rupture Bruchmodul Coefficient de rupture Módulo de rotura	N/mm ²	Conforme Conform Anforderungen erfuellt Conforme Conforme	≥ 35	UNI EN ISO 10545-4
Resistenza alle macchie Stain resistant Flecken beständigkeit Résistance au tâches Resistencia a las manchas	-	Conforme Conform Anforderungen erfuellt Conforme Conforme	3	UNI EN ISO 10545-14
Resistenza ai prodotti chimici di uso domestico Resistance to chemicals for household use Widerstandstahigkeit gegen Haushaltschemikalien Resistance aux produits d'usage domestique Resistencia a los productos químicos de uso doméstico	-	Conforme Conform Anforderungen erfuellt Conforme Conforme	B MIN	UNI EN ISO 10545-13

Lined writing area consisting of 30 horizontal dotted lines.



Uffici commerciali:
Via Statale, n° 99/D
42013 Dinazzano di Casalgrande - RE
Tel. +39 0522 773.611
Fax +39 0522 773.659/60
www.ceramichecerdisa.it
marketing@ceramichecerdisa.it